

**Series G Circuit Breakers**



<b>2.1</b>	<b>Introduction</b>	
	Product Overview	V4-T2-2
	Typical Applications	V4-T2-2
	Eaton Molded Case Circuit Breakers in Assemblies	V4-T2-3
<b>2.2</b>	<b>Series G®</b>	
	<i>Globally Accepted Breakers</i>	
	Product Overview	V4-T2-4
	Product Selection Overview	V4-T2-6
	Product Selection Guide	V4-T2-7
	Technical Data and Specifications	V4-T2-9
	Dimensions and Weights	V4-T2-14
	EG-Frame (15–125 Amperes)	V4-T2-15
	JG-Frame (63–250 Amperes)	V4-T2-29
	LG-Frame (250–630 Amperes)	V4-T2-47
	NG-Frame (320–1200 Amperes)	V4-T2-65
	RG-Frame (800–2500 Amperes)	V4-T2-74
	Motor Circuit Protectors (MCP)	V4-T2-85
	Motor Protector Circuit Breakers (MPCB)	V4-T2-89
	30 mA Ground Fault (Earth Leakage) Module	V4-T2-92
	Current Limiting Circuit Breaker Module	V4-T2-96
	High Instantaneous Circuit Breaker for Selective Coordination	V4-T2-101
	Special Features and Accessories	V4-T2-104
	Motor Operators	V4-T2-112
	Plug-In Blocks	V4-T2-114
	Drawout Cassette	V4-T2-115
<b>2.3</b>	<b>Series C®</b>	
	<i>North American Standards and Special Application Breakers</i>	
	Product Overview	V4-T2-116
	Standards and Certifications	V4-T2-117
	Quick Reference	V4-T2-118
	G-Frame (15–100 Amperes)	V4-T2-121
	F-Frame (10–225 Amperes)	V4-T2-135
	J-Frame (70–250 Amperes)	V4-T2-153
	K-Frame (70–400 Amperes)	V4-T2-161
	L-Frame (125–600 Amperes)	V4-T2-185
	M-Frame (300–800 Amperes)	V4-T2-211
	N-Frame (400–1200 Amperes)	V4-T2-222
	R-Frame (800–2500 Amperes)	V4-T2-237
	Motor Circuit Protectors (MCP)	V4-T2-256
	Motor Protection Circuit Breakers (MPCB)	V4-T2-267
	Type ELC Current Limiter Attachment (Size 0–4)	V4-T2-269
	Current Limiting Circuit Breaker Module	V4-T2-270
	Internal Accessories	V4-T2-273
	External Accessories	V4-T2-304
<b>2.4</b>	<b>Definite Purpose</b>	
	<i>Optimized solution for HVAC/R and Pumping Applications.</i>	
	Definite Purpose Molded Case Circuit Breakers	V4-T2-331
<b>2.5</b>	<b>Metering and Communications</b>	
	<i>Power Monitoring and Metering with Modbus RTU</i>	
	PM3 Monitoring and Metering Module	V4-T2-338
<b>2.6</b>	<b>Specialty</b>	
	<i>Specialty Breakers</i>	
	Engine Generator Circuit Breakers	V4-T2-341
	Direct Current Circuit Breakers	V4-T2-347
	PVGard™ Solar Circuit Breakers	V4-T2-361
	E2 Mining Service Breakers	V4-T2-374
	E2VAC Mining Vacuum Circuit Breaker	V4-T2-400
	Classic Mining Breakers	V4-T2-403
	Add-On Ground Fault Protection—Type GFR	V4-T2-417
<b>2.7</b>	<b>Handle Mechanisms</b>	
	Handle Mechanisms—Series G	V4-T2-420
	Handle Mechanisms—Series C	V4-T2-432



# Revision notes

## Volume 4—Circuit Protectors, CA08100005E

### Tab 2—Molded Case Circuit Breakers

Revision date	Section	Change page(s)	Description
11/30/2016	2.2	V4-T2-24	Content edits
11/30/2016	2.3	V4-T2-297	Content edits
11/30/2016	2.3	V4-T2-314	Content edits



*Powering Business Worldwide*

### Series G E-Frame and Series C F-Frame Molded Case Circuit Breakers



### Product Overview

#### Series G vs. Series C

Eaton's Electrical Sector, under the Eaton brand, offers the widest variety of molded case circuit breakers available today. Designed for electrical and machinery OEMs serving a range of industries and applications, these proven designs incorporate the latest in innovation with the high reliability that has been our hallmark since the advent of the circuit breaker in the 1920s.

The Series C family ranges from 15–2500 amperes, and includes thermal-magnetic breakers, electronic trip breakers, molded case switches, motor circuit protectors, and specially designed breakers for engine generator, DC and mining applications.

The new Series G line features an average 35% size reduction, common field-installable internal accessories, and advanced trip unit functionality that eliminates the need for rating plugs. These breakers meet the requirements of UL®, CSA®, IEC, CCC and CE, allowing the OEM to standardize on a design that meets the needs of their global customer base.

### Application Description

Eaton molded case circuit breakers cover the widest range of applications in the industry:

- Electrical OEMs
- Machinery OEMs
- Navy breakers:
  - UL 489 Supplement SB
  - MIL-C-17588
  - MIL-C-17361
  - ABS/NVR
- Mining breakers up to 1100 Vac
- Earth leakage
- DC breakers 125–750 Vdc
- Engine generator breakers 15–1200 amperes
- Current limiting breakers

### Typical Applications

#### Machine Tool Control Panels and Motor Control Centers

Designed for these equipment requirements, including new world-class accessories.

#### Panelboards

As both main and branch circuit protection devices.

### Contents

#### Description

Description	Page
Introduction	
Series G . . . . .	<b>V4-T2-4</b>
Series C . . . . .	<b>V4-T2-116</b>
Definite Purpose . . . . .	<b>V4-T2-331</b>
PM3 Monitoring and Metering Module . . . . .	<b>V4-T2-338</b>
Specialty Breakers . . . . .	<b>V4-T2-341</b>



Learn Online



Drawings Online

#### Feeder Pillars

In distribution systems to provide main and branch circuit protection.

#### Switchgear

In distribution systems to provide main and branch circuit protection up to 2500 amperes (RG-Frame).

#### Busbar Trunking Tap-Offs

In busbar trunking tap-offs to provide circuit protection.

#### Individual Enclosures

Completely assembled in enclosures to meet specific customer requirements.

#### Additional Applications

Special versions of each Eaton frame are available to provide safe equipment control and protection in mining and other applications. Contact your Eaton agent or distributor for additional information.

### Typical Eaton Applications

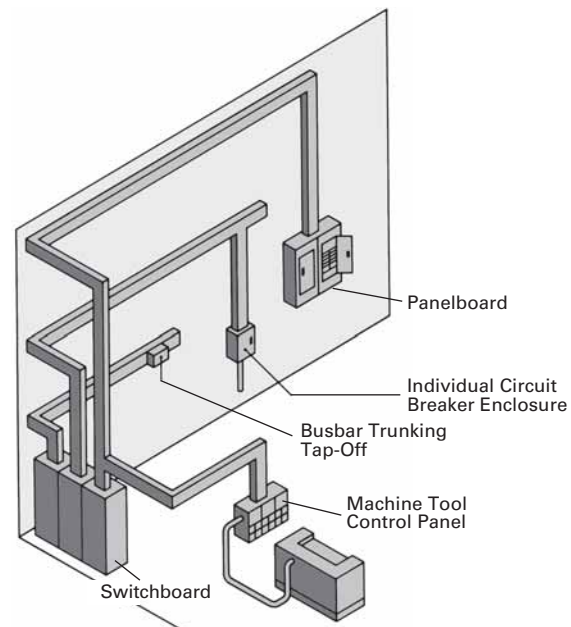

**Eaton Molded Case Circuit Breakers in Assemblies**

**Applications**

Frame	Ampere Range	Panelboards								Switchboards			Motor Control Centers			Enclosed Control	Bus Plugs	Enclosed Breaker	
		1A	2A	1A-LX	2A-LX	3A	3E	4	4B	4D	5P	PRL-C	PRL-i	PRL-C/i	Freedom				//
<b>Series G</b>																			
EG	15–160 ①	—	—	—	—	—	■	—	—	—	—	—	—	—	■	■	■	—	—
JG	20–250	—	—	—	—	—	—	—	—	—	■	—	—	—	—	—	—	—	—
LG	100–630 ②	■	■	—	—	■	■	■	■	■	—	■	—	■	—	—	—	—	■
NG	400–1600	—	—	—	—	—	—	—	■	■	—	■	■	■	■	■	—	—	■
RG	800–2500 ③	—	—	—	—	—	—	—	—	—	—	■	—	■	■	■	—	—	—
<b>Series C</b>																			
FD/ED	15–225	■	■	■	■	■	■	■	■	■	■	■	■	—	■	■	■	■	■
JD	70–250	■	■	—	—	■	—	■	■	■	■	■	■	—	■	■	■	■	■
KD	70–400	■	■	—	—	■	■	■	■	■	■	■	■	■	■	■	■	■	■
LD	400–600	—	—	—	—	■	—	■	■	■	■	■	■	■	■	■	■	■	■
MDL	300–800	—	—	—	—	—	—	■	■	■	■	■	■	■	■	■	■	■	■
ND	400–1200	—	—	—	—	—	—	■	■	■	■	■	■	■	■	■	■	■	■
RD	800–2500	—	—	—	—	—	—	—	—	—	■	■	—	■	■	—	—	—	—

**Notes**

- ① 125 amperes is the maximum UL and CSA rating for EG.
- ② 600 amperes is the maximum UL and CSA rating for LG.
- ③ 1200 amperes is the maximum UL and CSA rating for NG.

Series G, 15–2500 Amperes for UL, CSA and IEC Applications

2



## Contents

<i>Description</i>	<i>Page</i>
Series G	
Standards and Certifications . . . . .	<b>V4-T2-5</b>
Product Selection Overview . . . . .	<b>V4-T2-6</b>
Product Selection Guide . . . . .	<b>V4-T2-7</b>
Technical Data and Specifications . . . . .	<b>V4-T2-9</b>
Dimensions and Weights . . . . .	<b>V4-T2-14</b>
EG-Frame (15–125 Amperes) . . . . .	<b>V4-T2-15</b>
JG-Frame (63–250 Amperes) . . . . .	<b>V4-T2-29</b>
LG-Frame (250–630 Amperes) . . . . .	<b>V4-T2-47</b>
NG-Frame (320–1200 Amperes) . . . . .	<b>V4-T2-65</b>
RG-Frame (800–2500 Amperes) . . . . .	<b>V4-T2-74</b>
Motor Circuit Protectors (MCP) . . . . .	<b>V4-T2-85</b>
Motor Protector Circuit Breakers (MPCB) . . . . .	<b>V4-T2-89</b>
30 mA Ground Fault (Earth Leakage) Module . . . . .	<b>V4-T2-92</b>
Current Limiting Circuit Breaker Module . . . . .	<b>V4-T2-96</b>
High Instantaneous Circuit Breaker for	
Selective Coordination . . . . .	<b>V4-T2-101</b>
Special Features and Accessories . . . . .	<b>V4-T2-104</b>
Motor Operators . . . . .	<b>V4-T2-112</b>
Plug-In Blocks . . . . .	<b>V4-T2-114</b>
Drawout Cassette . . . . .	<b>V4-T2-115</b>

Learn  
OnlineDrawings  
Online

## Product Overview

### **Series G, 15–2500 Amperes for UL, CSA and IEC Applications**

Eaton Series G molded case circuit breakers provide increased performance in considerably less space than standard circuit breakers or comparable fusible devices.

The “G” signifies global applications: Series G circuit breakers are marked with UL, CSA, CE, IEC and KEMA KEUR listings. Other advantages include:

- Field-fit accessories
- Common accessories through 630 amperes
- Electronic trip units from 20 to 2500 amperes
- UL-listed and IEC-rated, 30 mA ground fault/earth leakage modules
- Built-in ground fault protection down to 20 amperes

The EG, JG and LG frames are designed around space-saving footprints. The NG and RG use the proven Eaton Series C ND and RD designs.

The Series G family includes five frame sizes in ratings from 15 to 2500 amperes. Series G offers a choice of several interrupting capacities up to 200 kA at 480 volts AC (200 kA at 240 volts AC).

Series G molded case circuit breakers are also available in direct current options. Please see Specialty Breakers **Section 2.6** for more details.

Standard calibration is 40 °C. For applications in high ambient temperature conditions, 50 °C factory calibration is available on thermal-magnetic breakers (not UL).

### **The Most Logically Designed Contact Assembly**

The flexibility and outstanding performance characteristics of Eaton circuit breakers are made possible by the best contact designs in circuit breaker history. Our technology creates a high-speed “blow-open” action using the electromechanical forces produced by high-level fault currents.

Eaton circuit breakers are operated by a toggle-type mechanism that is mechanically trip-free from the handle so that the contacts cannot be held closed against short circuit currents. Tripping due to overload or short circuits is clearly indicated by the position on the handle. This remarkably fast and dependable contact action is designed to enhance safety.

### **Thorough In-Plant Testing**

The quality, dependability and reliability of every Eaton Circuit Breaker is ensured by a thorough program of in-plant testing. Two calibration tests are conducted on every pole of every circuit breaker to verify the trip mechanism, operating mechanism, continuity and accuracy.

### **Current Limiting Characteristics**

Circuit breakers are current limiting because of their high repulsion contact arrangement and use of state-of-the-art arc extinguishing technology.

Eaton offers one of the most complete lines of current limiting breakers in the industry. The industrial breakers are available in current limiting versions with interrupting capacities up to 200 kA at 480 V without fuses in the same physical size as standard and high interrupting capacity breakers.

### Operating Mechanisms

Eaton circuit breakers have a toggle handle operating mechanism, which also serves as a switching position indicator. The indicator shows the positions of: ON, OFF and TRIPPED.

The toggle handle snaps into the TRIPPED position if the breaker is tripped by one of its overcurrent, short circuit, shunt or undervoltage releases. Before the circuit breaker can be reclosed following a trip-out, the toggle handle must be brought beyond the OFF position (RESET). The circuit breaker can then be reclosed.

As an additional switching position indicator for EG- to RG-Frame circuit breakers, there are two windows on the right and on the left of the toggle handle, in which the switching state is indicated by means of the colors red, green and white corresponding to the ON, OFF and TRIPPED positions respectively.

### Positions of the Toggle Handle Drive

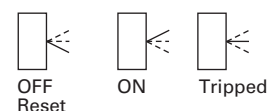

### Standards and Certifications

Eaton Series G circuit breakers meet applicable UL 489 and IEC 60947-2 standards.

Molded case circuit breakers from Eaton are designed to conform with the following international standards:

- Australian Standard AS 2184 and AS 3947-2 molded case circuit breakers
- British Standards Institution Standard EN60947.2
- International Electromechanical Commission Recommendations IEC 60947.2 circuit breakers
- CE
- Japanese T-Mark standard molded case circuit breakers
- National Electrical Manufacturers Association Standards Publication No. AB1-1993 molded case circuit breakers
- South African Bureau of Standards, Standard SANS 156, Standard Specification for molded case circuit breakers
- Swiss Electro-Technical Association Standard SEV 947.2, Safety Regulations for circuit breakers
- Union Technique de l'Electricite Standard NF C 63-120, low voltage switchgear and control gear circuit breaker requirements
- Verband Deutscher Elektrotechnike (Association of German Electrical Engineers) Standard VDE 0660, low voltage switchgear and control gear, circuit breakers

### Global Third-Party Certification

Certification marks ensure product compliance with the total standard via the third party witnessing of tests by globally recognized independent certification organizations.

KEMA is a highly recognized, independent international organization that offers certification and inspection facilities for equipment in many industries. The KEMA-KEUR mark is the highest certification an electrical product can receive from KEMA. Our IEC 60947-2 molded case circuit breakers are KEMA tested and certified. These breakers are also listed in accordance with UL 489, as well as CSA C22.2 No. 5-02.

KEMA, UL and CSA provide ongoing follow-up testing and inspections to ensure that Eaton molded case circuit breakers continue to meet their exacting standards.

### ISO Certification

Eaton circuit breakers are manufactured in ISO® certified facilities.

## Product Selection Overview

### Electronic Trip Units (Digitrip RMS Trip Units)—Multi-Function Electronic Trip Units for All Applications

2

#### True rms Sensing

Digitrip RMS trip units use Eaton's microprocessor-based intelligence to provide true rms sensing, permitting increased accuracy and reliable system protection. True rms sensing is not susceptible to nuisance tripping when waveforms containing high harmonic currents are present.

#### Digitrip RMS 310+

Digitrip RMS 310+ electronic trip units are available with Eaton Series G circuit breakers JG, LG, NG and RG, as well as Series C FD, KD, LD and MDL circuit breakers.

Digitrip 310+ trip units are equipped with an integrated  $I_r$  switch that allows users to modify the continuous current rating of the breaker without having to replace a rating plug. This provides further flexibility for coordination in systems. The trip units may be used in 50 Hz or 60 Hz applications. The Digitrip 310+ offers true rms sensing, is front adjustable and has an optional local display of current and cause of trip.

#### Curve Shaping

When selectively coordinated systems are called for, Digitrip RMS 310+ will provide a cost-effective solution for a variety of applications.

The standard Digitrip RMS 310+ includes an adjustable short time pickup setting encompassing an  $I^2t$  ramp function that provides the basic LS curve shaping function.

Digitrip 310+ trip units also include selectable long time delay ( $t_{LD}$ ) and pickup settings ( $I_r$ ). A rating plug is not required.

The optional Digitrip RMS 310+ LSI and LSI $G$  provide additional flat response short time delay adjustments and an instantaneous setting to provide LSI curve shaping capability.

Digitrip RMS 310+ LSG and LSI $G$  units are available with ground fault pickup and flat response ground fault delay. Ground fault alarm options are available with trip and no trip functionality as a means to notify users of a ground fault condition with the option to maintain the breaker online.

Digitrip RMS 310+ trip units can effectively coordinate with both sophisticated upstream power breakers as well as downstream thermal-magnetic breakers, making Digitrip RMS 310+ trip units the cost-effective reliable choice for selectively coordinated systems.

#### Thermal Memory

All Digitrip RMS trip units incorporate a long delay. Thermal memory prevents the system from cumulative overheating due to repeated overcurrent events that may occur in quick succession.

#### Field Testing

A field test kit is available for Digitrip RMS 310+ trip units.

#### Arcflash Reduction Maintenance Mode (ARMS)

ARMS is an available feature on KD, LG, LD, MDL, NG and RG frames with 310+ electronic trip units. This feature increases worker safety by providing an accelerated instantaneous trip unit to reduce arc flash. Additionally, LG, NG and RG frames with the ARMS feature include a fully adjustable instantaneous setting.

#### Digitrip RMS 610 and 910

Digitrip RMS 610 and 910 trip units are available with Eaton R-Frame circuit breakers 800 through 2500 amperes. Digitrip 610 and 910 trip units provide unparalleled system protection with the added convenience of a local display.

#### Curve Shaping

Digitrip RMS 610 and 910 trip units are available with up to nine curve shaping choices achieved by adjusting up to seven switches on the front of the unit for optimum system coordination. Maximum curve shaping flexibility is provided by dependent long and short delay adjustments that are long delay pickup ( $I_r$ ) based, depicted on the front of the unit by the blue portion of the time-current curve.

Additional coordination capability can be provided by utilizing the short delay and ground fault zone selective interlocking features available on these trip units.

#### System Diagnostics

Digitrip RMS 610 and 910 models of trip units provide long delay, short delay, instantaneous, and ground fault cause of trip LEDs on the front of the unit. Their display shows a magnitude of trip information, as well as remote signal contacts, for improved system alarming.

#### System Monitoring

Digitrip 610 and 910 trip units have the capability to monitor phase currents, as well as neutral or ground currents. This information is displayed on a large digital display mounted on the unit.

Digitrip RMS 910 trip units can also provide the user with power and energy monitoring capability. Peak power demand, present power demand, and total energy, as well as forward and reverse energy can be monitored with this unit.

Digitrip RMS 910 trip units have the additional capability of monitoring line-to-line voltage, as well as system power factor. Both parameters are displayed in the digital display window and are supported by LEDs to indicate which parameter is being displayed.

#### Harmonics Monitoring

Digitrip RMS 910 trip units are capable of displaying values of current harmonics in the digital display window. Percentage of harmonic content can be monitored for each phase, up to the 27th harmonic. Additionally, a total harmonic distortion value can be calculated and displayed.

#### Communications

Digitrip RMS 910 units have built-in communications options to allow all protection, monitoring, and control information to be transmitted back to a central location via the Eaton PowerNet™ system.

#### Field Testing

Integral field testing capability is provided on all 610 and 910 trip units. No additional test set is needed to perform both trip and no trip field testing.

## Product Selection Guide

## Electronic Trip Units

## Digitrip—RMS 310+, 610 and 910

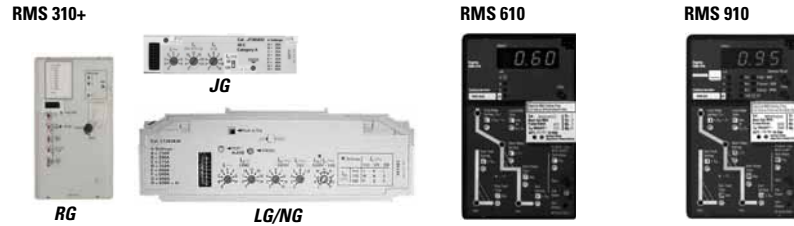

Breaker Type					
Series G frame(s)		JG-, LG-, NG- and RG-Frames		RG-Frame	RG-Frame
Ampere rating		20–2500 A		800–2500 A	800–2500 A
Interrupting rating at 415 V		35, 70, 100 kA		70, 100 kA	70, 100 kA
Trip Unit Sensing					
rms sensing		Yes		Yes	Yes
Protection and Coordination					
Protection	Ordering options	LS, LSG	LSI, LSIG	LI, LS, LSI, LIG, LSG, LSIG	LI, LS, LSI, LIG, LSG, LSIG
	Fixed rating plug ( $I_n$ ) <sup>①</sup>	Yes	Yes	Yes	Yes
	Overtemperature trip	Yes	Yes	Yes	Yes
Long delay	Adjustable $I_r$ switch	Yes	Yes	No	No
	Long delay setting	VAR/frame	VAR/frame	0.5–1.0 x ( $I_n$ )	0.5–1.0 x ( $I_n$ )
	Long delay time $I^2t$ at 6x	10 seconds <sup>②</sup>	10 seconds <sup>②</sup>	2–24 seconds	2–24 seconds
	Long delay thermal memory	Yes	Yes	Yes	Yes
	High load alarm	1.05 $I_r$	1.05 $I_r$	0.85 x $I_r$	0.85 x $I_r$
Short delay	Short delay setting	VAR/frame <sup>④</sup>	VAR/frame <sup>④</sup>	200–600% S1 and S2 x ( $I_r$ )	200–600% S1 and S2 x ( $I_r$ )
	Short delay time $I^2t$	100 ms	No	100, 300, 500 ms	100, 300, 500 ms
	Short delay time flat	No	l–300 ms	100–500 ms	100–500 ms
	Short delay time ZSI	No	Yes	Yes	Yes
Instantaneous	Independent adjustable Inst. setting	No	Yes <sup>⑤</sup>	Yes	Yes
	Instantaneous setting	No	VAR/frame	200–600% M1 and M2 x ( $I_n$ )	200–600% M1 and M2 x ( $I_n$ )
	Discriminator	No	No	Yes <sup>⑥</sup>	Yes <sup>⑥</sup>
	Instantaneous override	Yes	Yes	Yes	Yes
Ground fault	Ground fault setting	VAR/Frame <sup>⑦</sup>	VAR/Frame <sup>⑦</sup>	25–100% x ( $I_n$ ) <sup>⑦</sup>	25–100% x ( $I_n$ ) <sup>⑦</sup>
	Ground fault delay $I^2t$ at 0.62x	No	No	100, 300, 500 ms	100, 300, 500 ms
	Ground fault delay flat	l–300 ms	l–300 ms	100–500 ms	100–500 ms
	Ground fault ZSI	No	Yes	Yes	Yes
	Ground fault thermal memory	No	No	Yes	Yes

## Notes

$I_n$  = Rating plug rating.  
 $I_r$  = Long delay setting.

① 310+ trip units have selectable settings instead of a rating plug.

② 310+ trip units have adjustable long delay times of 2–24 seconds, except NG 310+ for 800 A frame, for which it is 2–14 seconds.

③ 310+ details are included by frame in **Pages V4-T2-44** (JG), **V4-T2-62** (LG), **V4-T2-72** (NG), and **V4-T2-83** (RG).

④ JG/LG: 2X–14X ( $I_n$ ); NG: 2X–8X ( $I_n$ ); RG: 2X–9X ( $I_n$ ); 2500 ampere RG-Frame 2X–6X x ( $I_n$ ).

⑤ LG, NG and RG ALSI and ALSIG 310+ trip units include an independently adjustable Instantaneous ( $I_i$ ) setting.

⑥ LS, LSG only.

⑦ Not to exceed 1200 amperes.

#### Digitrip—RMS 310+, 610 and 910, continued

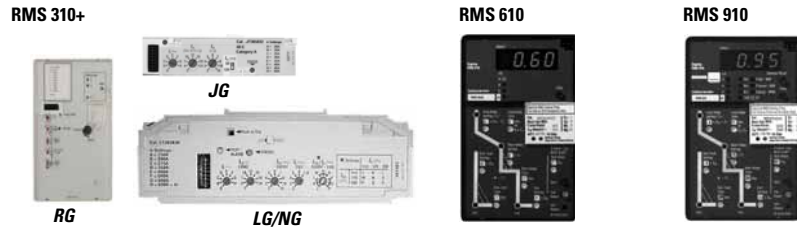

**LS, LSG**                      **LSI, LSIG**                      **LSI, LSIG, LSIG (A)**                      **LSI (A), LSIG**

	<b>LS, LSG</b>	<b>LSI, LSIG</b>	<b>LSI, LSIG, LSIG (A)</b>	<b>LSI (A), LSIG</b>
<b>System Diagnostics</b>				
Cause of trip LEDs	Yes <sup>①②</sup>	Yes <sup>①②</sup>	Yes	Yes
Magnitude of trip information	No	No	Yes	Yes
Remote signal contacts	No	No	Yes	Yes
<b>System Monitoring</b>				
Digital display	Yes <sup>③</sup>	Yes <sup>③</sup>	Yes	Yes
Current	Yes <sup>③</sup>	Yes <sup>③</sup>	Yes	Yes
Voltage	No	No	No	Yes
Power and energy	No	No	No	Yes
Power quality—harmonics	No	No	No	Yes
Power factor	No	No	No	Yes
<b>System Communications</b>				
PowerNet	No	No	No	Yes
<b>Field Testing</b>				
Testing method	Test set <sup>④</sup>	Test set <sup>④</sup>	Integral	Integral

**Notes**

- ① Using cause of trip module (catalog number **TRIP-LED**).
- ② RG 310+ trip units include integrated cause of trip LEDs.
- ③ Using ammeter or remote ammeter/cause of trip display (catalog number **DIGIVIEW** and **DIGIVIEWR06**).
- ④ Test kit available for field testing 310+ trip units (catalog number **MTST230V**).

Technical Data and Specifications

Ratings

Frames EG, JG and LG

EG



JG



LG



Maximum rated current (amperes)		125, 160 ①								250						400, 630 ②						
Breaker type ③		B	B	E	S	S	H	H	C	E	S	H	C	U	X	E	S	H	C	U	X	
Number of poles		1	2, 3, 4	2, 3, 4	1	2, 3, 4	1	2, 3, 4	3, 4	2, 3, 4	2, 3, 4	2, 3, 4	3, 4	3, 4	3, 4	3, 4	3, 4	3, 4	3, 4	3, 4	3, 4	
<b>Breaker Capacity (kA rms) Vac 50–60 Hz</b>																						
NEMA®, UL, CSA	240 Vac	25	25	35	85	85	100	100	200	65	85	100	200	200	200	65	85	100	200	200	200	
	480 Vac	—	18	25	—	35	—	65	100	25	35	65	100	150	200	35	50	65	100	150	200	
	600 Vac ④	—	—	18	—	22	—	25	35	18	18	25	35	50	50	18	25	35	50	65	65	
	125/250 Vdc ⑤	10 ⑥	10	10	35 ⑥	35	42 ⑥	42	42	10	22	22	42	50	50	22	22	42	42	50	50	
IEC 60947-2	220–240 Vac	<i>I<sub>CU</sub></i>	25	25	35	85	85	100	100	200	65	85	100	200	200	200	65	85	100	200	200	200
		<i>I<sub>CS</sub></i>	25	25	35	43	43	50	50	200	65	85	100	200	200	200	65	85	100	200	200	200
	380–415 Vac	<i>I<sub>CU</sub></i>	—	18	25	—	40	—	70	100	25	40	70	100	150	200	35	50	70	100	150	200
		<i>I<sub>CS</sub></i>	—	18	25	—	30	—	35	100	25	40	70	100	150	200	35	50	53	100	150	200
	660–690 Vac	<i>I<sub>CU</sub></i>	—	—	—	—	—	—	—	—	12	12	14	16	18	18	12	20	25	30	35	35
		<i>I<sub>CS</sub></i>	—	—	—	—	—	—	—	—	6	6	7	12	14	14	6	10	13	15	18	18
	125/250 Vdc ⑤	<i>I<sub>CU</sub></i>	10 ⑥	10	10	35 ⑥	35	42 ⑥	42	42	10	22	22	42	50	50	22	22	42	42	50	50
		<i>I<sub>CS</sub></i>	10 ⑥	10	10	35 ⑥	35	42 ⑥	42	42	10	22	22	42	50	50	22	22	42	42	50	50
Ampere range		15–160 A ①								20–250 A						100–630 A ②						
Trip Units		FT-FM								FT-AM						FT-AM						
F = Fixed		AT-FM								AT-AM						AT-AM						
A = Adjustable										Electronic (Digitrip RMS 310)						Electronic (Digitrip RMS 310)						
T = Thermal																						
M = Magnetic																						
Interchangeable		—	—	—	—	—	—	—	—	■	■	■	■	■	■	■	■	■	■	■	■	
Built-in		■	■	■	■	■	■	■	■	■	■	■	■	■	■	■	■	■	■	■	■	
Thermal magnetic	Fixed thermal	■	■	■	■	■	■	■	■	■	■	■	■	■	■	■	■	■	■	■	■	
	Adjustable thermal	■	■	■	■	■	■	■	■	■	■	■	■	■	■	■	■	■	■	■	■	
	Magnetic	Fixed								Adjustable						Adjustable						
Electronic RMS ⑦	LS	—	—	—	—	—	—	—	—	■	■	■	■	■	■	■	■	■	■	■	■	
	LSI	—	—	—	—	—	—	—	—	■	■	■	■	■	■	■	■	■	■	■	■	
	LSG	—	—	—	—	—	—	—	—	■	■	■	■	■	■	■	■	■	■	■	■	
	LSIG	—	—	—	—	—	—	—	—	■	■	■	■	■	■	■	■	■	■	■	■	
	ALSI	—	—	—	—	—	—	—	—	—	—	—	—	—	—	■	■	■	■	■	■	
	ALSIG	—	—	—	—	—	—	—	—	—	—	—	—	—	—	■	■	■	■	■	■	
Utilization category		A	A	A	A	A	A	A	A	A	A	A	A	A	A	A	A	A	A	A	A	

Notes

- ① 125 amperes is the maximum UL and CSA rating for the EG.
- ② 630 amperes is not a UL or CSA listed rating. 600 amperes is the maximum UL and CSA listed rating for the LG.
- ③ Breaker type C, U and X are current limiting per UL 489.
- ④ EG breaker rated 600/347 Vac.
- ⑤ Two poles in series.
- ⑥ 125 Vdc only for single-pole breakers.
- ⑦ Not suitable for DC application. Four-pole ground fault not available.

# 2.2

## Molded Case Circuit Breakers

### Series G

#### Frames NG and RG

NG



RG



Maximum rated current (amperes)		800, 1200	800, 1200	800, 1200	1600 <sup>①</sup>	800	1600, 2000, 2500	1600, 2000, 2500	
Breaker type		S	H	C <sup>②</sup>	S	U	H	C <sup>②</sup>	
Number of poles		2, 3, 4	2, 3, 4	2, 3, 4	3	3	3, 4	3, 4	
<b>Breaker Capacity (kA rms) AC 50–60 Hz</b>									
NEMA, UL, CSA	240 Vac	85	100	200	—	200	125	200	
	480 Vac	50	65	100	—	150	65	100	
	600 Vac	25	35	65	—	65	50	65	
IEC 60947-2	220–240 Vac	$I_{cu}$	85	100	200	85	—	135	200
		$I_{cs}$	85	100	100	85	—	100	100
	380–415 Vac	$I_{cu}$	50	70	100	50	—	70	100
		$I_{cs}$	50	50	50	50	—	50	50
	660–690 Vac	$I_{cu}$	20 <sup>③</sup>	25 <sup>③</sup>	35	20 <sup>③</sup>	—	25 <sup>③</sup>	35 <sup>③</sup>
		$I_{cs}$	10	13	18	10	—	13	18
	250 Vdc	$I_{cu}$	—	—	—	—	—	—	—
		$I_{cs}$	—	—	—	—	—	—	—
Ampere range		400–1200 A	400–1200 A	400–1200 A	1600 A	800 A	800–2500 A	800–2500 A	
Trip units		Electronic (Digitrip RMS 310+)				Electronic (Digitrip RMS 310+ and 910)			
	Interchangeable	—	—	—	—	—	■ <sup>⑤</sup>	■ <sup>⑤</sup>	
	Built-in	■	■	■	■	■	■	■	
Electronic <sup>④</sup>	LI	—	—	—	—	—	■ <sup>⑥</sup>	■ <sup>⑥</sup>	
	LS	■	■	■	■	■	■	■	
	LSI	■	■	■	■	■	■	■	
	LIG	—	—	—	—	—	■ <sup>⑥</sup>	■ <sup>⑥</sup>	
	LSG	■	■	■	■	■	■	■	
	LSIG	■	■	■	■	■	■	■	
	ALSI	■	■	■	■	—	■	■	
	ALSIG	■	■	■	■	—	■	■	
Utilization category		A	A	A	A	A	A	A	

#### Notes

- ① NG 1600 ampere frame is not UL or CSA listed.
- ② Not KEMA-KEUR listed.
- ③ IEC 60947-2 H.5 Annex H is not KEMA-KEUR tested.
- ④ Not suitable for DC application. Four-pole ground fault not available.
- ⑤ RG 310+ are interchangeable with the exception of: FROM not ground fault equipped TO ground fault equipped
- ⑥ Available only on Digitrip 910 trip units.

## General Specifications

### All Series G Frames

	EG		JG		LG		NG		RG	
Maximum rated current $I_n$ depending on the version	160 A <sup>①</sup>		250 A		400, 630 A <sup>②</sup>		800, 1200, 1600 A <sup>③</sup>		1600, 2000, 2500 A	
Rated insulation voltage U, according to IEC 60947-2										
Main conducting paths	500 Vac		750 Vac		750 Vac		750 Vac		750 Vac	
Auxiliary circuits	500 Vac		690 Vac		690 Vac		690 Vac		690 Vac	
Rated impulse withstand voltage $U_{imp}$										
Main conducting paths	6 kV		8 kV		8 kV		8 kV		8 kV	
Auxiliary circuits	4 kV		4 kV		4 kV		4 kV		4 kV	
Rated operational voltage $U_g$										
IEC	415 Vac		690 Vac		690 Vac		690 Vac		690 Vac	
NEMA	600Y/347 Vac		600 Vac		600 Vac		600 Vac		600 Vac	
UL and CSA listed	Yes <sup>①</sup>		Yes		Yes <sup>②</sup>		Yes <sup>③</sup>		Yes	
Permissible ambient temperature	-20 ° to 70 °C		-20 ° to 70 °C		-20 ° to 70 °C		-20 ° to 70 °C		-20 ° to 70 °C	
Permissible load for various ambient temperatures close to the circuit breaker, related to the rated current of the circuit breaker	④      ⑤		④      ⑤		④      ⑤		—		—	
Circuit breakers for plant protection										
At 40 °C	100%	100%	100%	100%	100%	100%	100%	100%	100%	100%
At 50 °C	96%	92%	96%	94%	96%	91%	91%	91%	91%	91%
At 55 °C	93%	87%	94%	90%	93%	86%	85%	85%	85%	85%
At 60 °C	91%	83%	92%	87%	90%	82%	81%	81%	81%	81%
At 70 °C	86%	73%	88%	80%	84%	70%	70%	70%	70%	70%
Circuit breakers for motor protection										
At 40 °C	—		100%		100%		—		—	
At 50 °C	—		100%		100%		—		—	
At 55 °C	—		100%		100%		—		—	
At 60 °C	—		100%		100%		—		—	
At 70 °C	—		90%		90%		—		—	
Circuit breakers for starter combinations and isolating circuit breakers										
At 40 °C	100%		100%		100%		100%		100%	
At 50 °C	100%		100%		100%		91%		91%	
At 55 °C	96%		96%		95%		85%		85%	
At 60 °C	91%		82%		90%		81%		81%	
At 70 °C	86%		88%		84%		—		—	
Rated short-circuit breaking capacity (DC) Not for circuit breakers for motor protection (Time constant $t = 10$ rms)										
Two conducting paths in series For EG to LG up to 250 Vdc	42 kA max.		42 kA max.		42 kA max.		⑥		⑥	
NEMA (time constant $t = 8$ rms) Two conducting paths in series 250 Vdc	42 kA max.		42 kA max.		42 kA max.		⑥		⑥	

#### Notes

- ① 125 amperes is the maximum UL and CSA rating for the EG.
- ② 630 amperes is not a UL or CSA listed rating. 600 amperes is the maximum UL and CSA rating for the LG.
- ③ 1200 amperes is the maximum UL and CSA rating for the NG.
- ④ Thermal overload release set to the lower value.
- ⑤ Thermal overload release set to the upper value.
- ⑥ Not suitable for DC switching.

### All Series G Frames, continued

2

	EG	JG	LG	NG	RG	
Main switch characteristics according to IEC 60947-2 in combination with lockable rotary drives	Yes	Yes	Yes	Yes	Yes	
Rated short circuit breaking capacity according to IEC 60947-2 (at AC 50/60 Hz)	For rated short circuit breaking capacity, see <b>Page V4-T2-9</b> .					
Endurance (operating cycles)	10,000	10,000	8,000	3,000	3,000	
Maximum switching frequency	300 1/h	240 1/h	240 1/h	60 1/h	60 1/h	
Conductor cross sections and terminal types for main conductors	Box terminals	Box terminals	Box terminals	Flat bar terminals	Flat bar terminals	Flat bar terminals
Solid or stranded	2.5 to 95 mm <sup>2</sup>	50 to 150 mm <sup>2</sup>	95 to 240 mm <sup>2</sup>	—	—	—
Finely stranded with end sleeve	2.5 to 50/70 mm <sup>2</sup>	35 to 120 mm <sup>2</sup>	70 to 150 mm <sup>2</sup>	—	—	—
Busbar	—	—	—	600 A	Optional	Optional
Tightening torque for box terminals	5.6 Nm	20 Nm	42 Nm	31 Nm	31 Nm	—
Tightening torque for busbar connection pieces	5.6 Nm	15 Nm	30 Nm	6 Nm	50 Nm	20 Nm
Conductor cross sections for auxiliary circuits with terminal connection or terminal strip						
Solid	0.75 to 2.5 mm <sup>2</sup>	0.75 to 2.5 mm <sup>2</sup>	0.75 to 2.5 mm <sup>2</sup>	Up to 2x4 mm <sup>2</sup>	Up to 2x4 mm <sup>2</sup>	
Finely stranded with end sleeve	0.75 to 2.5 mm <sup>2</sup>	0.75 to 2.5 mm <sup>2</sup>	0.75 to 2.5 mm <sup>2</sup>	Up to 2x2.5 mm <sup>2</sup>	Up to 2x2.5 mm <sup>2</sup>	
With brought-out cable ends	—	0.82 (AWG 18) mm <sup>2</sup>	0.82 (AWG 18) mm <sup>2</sup>	0.82 (AWG 18) mm <sup>2</sup>	0.82 (AWG 18) mm <sup>2</sup>	
Tightening torque for fitting screws	—	0.8 to 1.4 Nm	0.8 to 1.4 Nm	0.8 to 1.4 Nm	0.8 to 1.4 Nm	
Power loss per circuit breaker at maximum rated current I <sub>n</sub> (the power losses of the undervoltage releases ("r" releases) must be observed if necessary) at three-phase symmetrical load)			<b>400 A:</b>	<b>600 A:</b>		
For plant protection	40 W	45 W	65 W	120 W	87/210 W	220/270/400 W
As isolating circuit breaker	40 W	45 W	65 W	120 W	87/210 W	220/270/400 W
For starter combinations	40 W	45 W	65 W	120 W	—	—
For motor protection	—	45 W	65 W	120 W	—	—
Permissible mounting position						
Arc spacing— suitable for reverse-feed applications	Yes (except HMCPE)	Yes	Yes	Yes	Yes	
<b>Auxiliary Switches</b>						
Rated thermal current I <sub>th</sub>	6A	6A	6A	6A	6A	
Rated making capacity	20 A	20 A	20 A	20 A	20 A	
	<b>AC-14</b>	<b>AC-14</b>	<b>AC-14</b>	<b>AC-15</b>	<b>AC-15</b>	
Rated operational voltage	230/400/600 V	230/400/600 V	230/400/600 V	600 V	600 V	
Rated operational current	6/3/0.25 A	6/3/0.25 A	6/3/0.25 A	6A	6A	
				<b>DC-13</b>	<b>DC-13</b>	
Rated operational voltage	125/250V	125/250V	125/250V	125/250V	125/250V	
Rated operational current	0.5/0.15 A	0.5/0.15 A	0.5/0.15 A	0.5/0.25 A	0.5/0.25 A	
Backup fuse	6/4/4 A	(4) 6/4/4 A	(4) 6/4/4 A	(4) 6/4/4 A	(4) 6/4/4 A	
Miniature circuit breaker	6/4 A	6/4 A	6/4 A	6/4 A	6/4 A	

## All Series G Frames, continued

	EG	JG	LG	NG	RG
<b>Releases</b>					
Undervoltage releases ("r" releases)					
Response voltage:					
Drop (breaker tripped) $U_s$	35–70%	35–70%	35–70%	35–70%	35–70%
Pickup (breaker may be switched on) $U_s$	85–110%	85–110%	85–110%	85–110%	85–110%
Power consumption in continuous operation at:					
50/60 Hz 12 Vac	—	—	—	1.9 VA	2.9 VA
50/60 Hz 24 Vac	0.72 VA	3.9 VA	3.9 VA	2.4 VA	3.1 VA
50/60 Hz 48–60 Vac	1.15–1.78 VA	2.5–3.8 VA	2.5–3.8 VA	2.3–4.1 VA	3.4–6.0 VA
50/60 Hz 110–127 Vac	0.96–1.25 VA	1.8–2.4 VA	1.8–2.4 VA	3.4–4.2 VA	3.3–3.8 VA
50/60 Hz 208–240 Vac	1.28–1.68 VA	2.7–3.8 VA	2.7–3.8 VA	4.8–6.5 VA	4.2–7.2 VA
50/60 Hz 380–500 Vac	2.2–3.9 VA	3.4–5.8 VA	3.4–5.8 VA	6.8–12.0 VA	3.8–10.0 VA
50/60 Hz 525–600 Vac	3.4–4.3 VA	3.4–4.3 VA	3.4–4.3 VA	—	—
12 Vdc	—	—	—	2.6W	3.4W
24 Vdc	0.70 W	3.1W	3.1W	3.6W	4.3W
48–60 Vdc	1.12–1.76W	2.0–3.1W	2.0–3.1W	3.5–5.5W	4.8–7.2W
110–125 Vdc	0.94–1.21W	1.6–2.2W	1.6–2.2W	2.9–3.6W	3.3–3.8W
220–250 Vdc	1.45–1.86W	3.1–4W	3.1–4W	4.8–6.3W	6.6–7.5W
Maximum opening time	50 ms	50 ms	50 ms	62 ms	62 ms
<b>Shunt Trips</b>					
Shunt trips ("f" releases)					
Response voltage:					
Pickup (breaker tripped) $U_s$	70–110%	70–110%	70–110%	70–110%	70–110%
Power consumption in (short time) at:					
50/60 Hz 24 Vac	10–41 VA	87–405 VA	87–405 VA	98–475 VA	612 VA
50/60 Hz 48–60 Vac	139–210 VA	710–1105 VA	710–1105 VA	24–50 VA	403–666 VA
50/60 Hz 48–127 Vac	—	—	—	—	—
50/60 Hz 110–240 Vac	83–360 VA	66–432 VA	66–432 VA	67–432 VA	396–1896 VA
50/60 Hz 380–440 Vac	—	127–188 VA	127–188 VA	76–110 VA	1596–2156 VA
50/60 Hz 380–600 Vac	418–1080 VA	—	—	—	—
50/60 Hz 480–600 Vac	—	34–60 VA	34–60 VA	19–42 VA	230–384 VA
12–24 Vdc	29–120 W	164–631 W	164–631 W	145–610 W	396 W
48–60 Vdc	475–720 W	830–1580 W	830–1580 W	67–102 W	341–528 W
110–125 Vdc	99–121 W	112–150 W	112–150 W	121–150 W	264–350 W
220–250 Vdc	—	40–58W	40–58 W	46–55 W	374–475 W
Maximum load duration	Interrupts automatically	Interrupts automatically	Interrupts automatically	Interrupts automatically	Interrupts automatically
Maximum opening time	50 ms	50 ms	50 ms	62 ms	62 ms
<b>Molded Case Switch (with High Magnetic Trip)</b>					
Unfused kAIC at 480 Vac (415 Vac)	65 (70)	65 (70)	65 (70)	65 (70)	65 (70)
Self-protected, will trip above	1250 for EG125; 1600 for EG160	2500	4000/6300	12,500	20,000

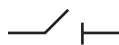

# 2.2

## Molded Case Circuit Breakers

### Series G

#### Dimensions and Weights

Approximate Dimensions in Inches (mm)

2

##### Series G—Frame EG, JG and LG

	EG			JG			LG		
	H	W	D	H	W	D	H	W	D
<b>Single-pole</b>	5.50 (139.7)	1.00 (25.4)	2.99 (76.0)	—	—	—	—	—	—
<b>Two-pole</b>	5.50 (139.7)	2.00 (50.8)	2.99 (76.0)	7.00 (177.8)	4.13 (105.0)	3.57 (87.4)	—	—	—
<b>Three-pole</b>	5.50 (139.7)	3.00 (76.2)	2.99 (76.0)	7.00 (177.8)	4.13 (105.0)	3.57 (87.4)	10.13 (258.0)	5.48 (140.0)	4.09 (104.0)
<b>Four-pole</b>	5.50 (139.7)	4.00 (101.6)	2.99 (76.0)	7.00 (177.8)	5.34 (135.6)	3.57 (87.4)	10.13 (258.0)	7.22 (183.0)	4.09 (104.0)

##### Series G—Frame NG and RG

	NG			RG		
	H	W	D	H	W	D
<b>Single-pole</b>	—	—	—	—	—	—
<b>Two-pole</b>	—	—	—	—	—	—
<b>Three-pole</b>	16.00 (406.0)	8.25 (210.0)	5.50 (140.0)	16.00 (406.0)	15.50 (394.0)	9.75 (229.0)
<b>Four-pole</b>	16.00 (406.0)	11.13 (280.0)	5.50 (140.0)	16.00 (406.0)	20.00 (508.0)	9.75 (229.0)

Approximate Shipping Weight in Lbs (kg)

##### Series G—Frame EG, JG and LG

	EG	JG	LG	NG	RG
<b>Single-pole</b>	0.85 (0.39)	—	—	—	—
<b>Two-pole</b>	1.57 (0.71)	11.3 (5.13)	—	—	—
<b>Three-pole</b>	2.28 (1.04)	5.06 (2.30) T/M 5.31 (2.41) ETU	12.36 (5.61) T/M 13.04 (5.92) ETU	46.8 (21.3)	103.0 (47.0)
<b>Four-pole</b>	2.85 (1.29)	6.76 (3.07) T/M 7.12 (3.23) ETU	16.27 (7.39) T/M 16.92 (7.68) ETU	62.0 (28.3)	118.4 (54.0)

**EG-Frame (15–125 Amperes)****EG-Frame (15–125 Amperes)****Product Description**

EG breaker is HACR rated.

**Contents****Description****Page**

EG-Frame (15–125 Amperes)	
Catalog Number Selection . . . . .	<b>V4-T2-16</b>
Product Selection . . . . .	<b>V4-T2-17</b>
Accessories . . . . .	<b>V4-T2-26</b>
Technical Data and Specifications . . . . .	<b>V4-T2-27</b>
Dimensions and Weights. . . . .	<b>V4-T2-27</b>
JG-Frame (63–250 Amperes) . . . . .	<b>V4-T2-29</b>
LG-Frame (250–630 Amperes) . . . . .	<b>V4-T2-47</b>
NG-Frame (320–1200 Amperes) . . . . .	<b>V4-T2-65</b>
RG-Frame (800–2500 Amperes) . . . . .	<b>V4-T2-74</b>
Motor Circuit Protectors (MCP) . . . . .	<b>V4-T2-85</b>
Motor Protector Circuit Breakers (MPCB). . . . .	<b>V4-T2-89</b>
30 mA Ground Fault (Earth Leakage) Module. . . . .	<b>V4-T2-92</b>
Current Limiting Circuit Breaker Module . . . . .	<b>V4-T2-96</b>
High Instantaneous Circuit Breaker for	
Selective Coordination . . . . .	<b>V4-T2-101</b>
Special Features and Accessories. . . . .	<b>V4-T2-104</b>
Motor Operators . . . . .	<b>V4-T2-112</b>
Plug-In Blocks . . . . .	<b>V4-T2-114</b>
Drawout Cassette . . . . .	<b>V4-T2-115</b>

# 2.2

## Molded Case Circuit Breakers

### Series G

2

#### Catalog Number Selection

This information is presented only as an aid to understanding catalog numbers. It is not to be used to build catalog numbers for circuit breakers or trip units.

#### Series G—EG-Frame (15–125 Amperes)

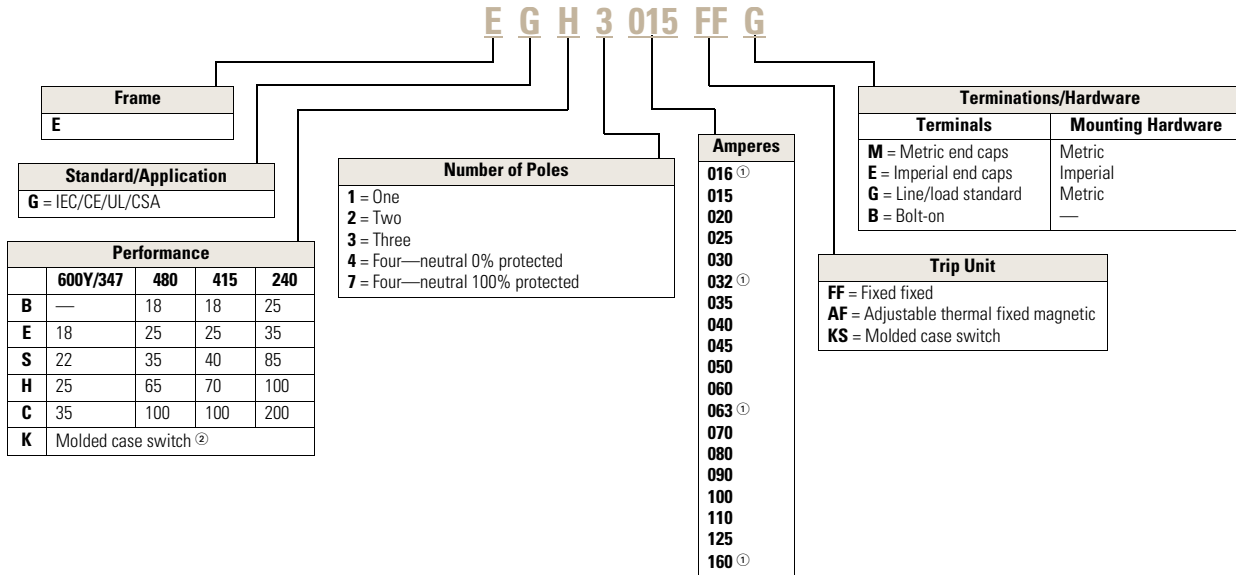

#### Notes

- <sup>①</sup> Cannot be UL rated.
- <sup>②</sup> Available only as 125 and 160 A sizes.

## Product Selection

Complete Breaker (Includes Frame, Trip Unit, Standard Terminals and Mounting Hardware) IC Rating at 415/480 Volts

EG-Frame



## EG-Frame — 18/18

Maximum Continuous Amps at 40 °C ①	Single-Pole	Two-Pole	Three-Pole	Adjustable ② Thermal, Fixed Magnetic	Four-Pole ③	Adjustable ② Thermal, Fixed Magnetic
	Fixed Thermal, Fixed Magnetic Catalog Number	Fixed Thermal, Fixed Magnetic Catalog Number	Fixed Thermal, Fixed Magnetic Catalog Number	Fixed Thermal, Fixed Magnetic Catalog Number	Fixed Thermal, Fixed Magnetic Catalog Number	Fixed Thermal, Fixed Magnetic Catalog Number
15	EGB1015FFG	EGB2015FFG	EGB3015FFG	—	EGB4015FFG	—
16	EGB1016FFG	EGB2016FFG	EGB3016FFG	—	EGB4016FFG	—
20	EGB1020FFG	EGB2020FFG	EGB3020FFG	—	EGB4020FFG	EGB4020AFG
25	EGB1025FFG	EGB2025FFG	EGB3025FFG	EGB3025AFG	EGB4025FFG	EGB4025AFG
30	EGB1030FFG	EGB2030FFG	EGB3030FFG	—	EGB4030FFG	—
32	EGB1032FFG	EGB2032FFG	EGB3032FFG	EGB3032AFG	EGB4032FFG	EGB4032AFG
35	EGB1035FFG	EGB2035FFG	EGB3035FFG	—	EGB4035FFG	—
40	EGB1040FFG	EGB2040FFG	EGB3040FFG	EGB3040AFG	EGB4040FFG	EGB4040AFG
45	EGB1045FFG	EGB2045FFG	EGB3045FFG	—	EGB4045FFG	—
50	EGB1050FFG	EGB2050FFG	EGB3050FFG	EGB3050AFG	EGB4050FFG	EGB4050AFG
60	EGB1060FFG	EGB2060FFG	EGB3060FFG	—	EGB4060FFG	—
63	EGB1063FFG	EGB2063FFG	EGB3063FFG	EGB3063AFG	EGB4063FFG	EGB4063AFG
70	EGB1070FFG	EGB2070FFG	EGB3070FFG	—	EGB4070FFG	—
80	EGB1080FFG	EGB2080FFG	EGB3080FFG	EGB3080AFG	EGB4080FFG	EGB4080AFG
90	EGB1090FFG	EGB2090FFG	EGB3090FFG	—	EGB4090FFG	—
100	EGB1100FFG	EGB2100FFG	EGB3100FFG	EGB3100AFG	EGB4100FFG	EGB4100AFG
110	EGB1110FFG	EGB2110FFG	EGB3110FFG	—	EGB4110FFG	—
125	EGB1125FFG	EGB2125FFG	EGB3125FFG	EGB3125AFG	EGB4125FFG	EGB4125AFG
160	—	—	EGB3160FFG	EGB3160AFG	EGB4160FFG	EGB4160AFG

**Notes**

① 16, 32, 63 and 160 A are not UL listed ratings.

② Adjustable thermal are not UL listed.

③ Change the fourth digit to 7 for 100% neutral protection. Neutral is on the LH side.

# 2.2

## Molded Case Circuit Breakers

### Series G

EG-Frame—25/25 Single-Pole Unavailable

2

EG-Frame

EG-Frame—25/25



Maximum Continuous Amps at 40 °C <sup>①</sup>	Two-Pole	Three-Pole	Adjustable <sup>②</sup> Thermal, Fixed Magnetic Catalog Number	Four-Pole <sup>③</sup>	Adjustable <sup>②</sup> Thermal, Fixed Magnetic Catalog Number
	Fixed Thermal, Fixed Magnetic Catalog Number	Fixed Thermal, Fixed Magnetic Catalog Number		Fixed Thermal, Fixed Magnetic Catalog Number	
15	EGE2015FFG	EGE3015FFG	—	EGE4015FFG	—
16	EGE2016FFG	EGE3016FFG	—	EGE4016FFG	—
20	EGE2020FFG	EGE3020FFG	—	EGE4020FFG	EGE4020AFG
25	EGE2025FFG	EGE3025FFG	EGE3025AFG	EGE4025FFG	EGE4025AFG
30	EGE2030FFG	EGE3030FFG	—	EGE4030FFG	—
32	EGE2032FFG	EGE3032FFG	EGE3032AFG	EGE4032FFG	EGE4032AFG
35	EGE2035FFG	EGE3035FFG	—	EGE4035FFG	—
40	EGE2040FFG	EGE3040FFG	EGE3040AFG	EGE4040FFG	EGE4040AFG
45	EGE2045FFG	EGE3045FFG	EGE3050AFG	EGE4045FFG	—
50	EGE2050FFG	EGE3050FFG	—	EGE4050FFG	EGE4050AFG
60	EGE2060FFG	EGE3060FFG	—	EGE4060FFG	—
63	EGE2063FFG	EGE3063FFG	EGE3063AFG	EGE4063FFG	EGE4063AFG
70	EGE2070FFG	EGE3070FFG	—	EGE4070FFG	—
80	EGE2080FFG	EGE3080FFG	EGE3080AFG	EGE4080FFG	EGE4080AFG
90	EGE2090FFG	EGE3090FFG	—	EGE4090FFG	—
100	EGE2100FFG	EGE3100FFG	EGE3100AFG	EGE4100FFG	EGE4100AFG
125	EGE2125FFG	EGE3125FFG	EGE3125AFG	EGE4125FFG	EGE4125AFG
160	—	EGE3160FFG	EGE3160AFG	EGE4160FFG	EGE4160AFG

**Notes**

- ① 16, 32, 63 and 160 A are not UL listed ratings.
- ② Adjustable thermal are not UL listed.
- ③ Change the fourth digit to 7 for 100% neutral protection. Neutral is on the LH side.

## EG-Frame



## EG-Frame—40/35

Maximum Continuous Amps at 40 °C <sup>①</sup>	Single-Pole	Two-Pole	Three-Pole	Adjustable Thermal, Fixed Magnetic <sup>②</sup> Catalog Number	Four-Pole <sup>③</sup>	Adjustable <sup>②</sup> Thermal, Fixed Magnetic Catalog Number
	Fixed Thermal, Fixed Magnetic Catalog Number	Fixed Thermal, Fixed Magnetic Catalog Number	Fixed Thermal, Fixed Magnetic Catalog Number		Fixed Thermal, Fixed Magnetic Catalog Number	
15	EGS1015FFG	EGS2015FFG	EGS3015FFG	—	EGS4015FFG	—
16	EGS1016FFG	EGS2016FFG	EGS3016FFG	—	EGS4016FFG	—
20	EGS1020FFG	EGS2020FFG	EGS3020FFG	—	EGS4020FFG	EGS4020AFG
25	EGS1025FFG	EGS2025FFG	EGS3025FFG	EGS3025AFG	EGS4025FFG	EGS4025AFG
30	EGS1030FFG	EGS2030FFG	EGS3030FFG	—	EGS4030FFG	—
32	EGS1032FFG	EGS2032FFG	EGS3032FFG	EGS3032AFG	EGS4032FFG	EGS4032AFG
35	EGS1035FFG	EGS2035FFG	EGS3035FFG	—	EGS4035FFG	—
40	EGS1040FFG	EGS2040FFG	EGS3040FFG	EGS3040AFG	EGS4040FFG	EGS4040AFG
45	EGS1045FFG	EGS2045FFG	EGS3045FFG	—	EGS4045FFG	—
50	EGS1050FFG	EGS2050FFG	EGS3050FFG	EGS3050AFG	EGS4050FFG	EGS4050AFG
60	EGS1060FFG	EGS2060FFG	EGS3060FFG	—	EGS4060FFG	—
63	EGS1063FFG	EGS2063FFG	EGS3063FFG	EGS3063AFG	EGS4063FFG	EGS4063AFG
70	EGS1070FFG	EGS2070FFG	EGS3070FFG	—	EGS4070FFG	—
80	EGS1080FFG	EGS2080FFG	EGS3080FFG	EGS3080AFG	EGS4080FFG	EGS4080AFG
90	EGS1090FFG	EGS2090FFG	EGS3090FFG	—	EGS4090FFG	—
100	EGS1100FFG	EGS2100FFG	EGS3100FFG	EGS3100AFG	EGS4100FFG	EGS4100AFG
125	EGS1125FFG	EGS2125FFG	EGS3125FFG	EGS3125AFG	EGS4125FFG	EGS4125AFG
160	—	—	EGS3160FFG	EGS3160AFG	EGS4160FFG	EGS4160AFG

**Notes**

- ① 16, 32, 63 and 160 A are not UL listed ratings.  
 ② Adjustable thermal are not UL listed.  
 ③ Change the fourth digit to 7 for 100% neutral protection. Neutral is on the LH side.

EG-Frame



## EG-Frame—70/65

Maximum Continuous Amps at 40 °C <sup>①</sup>	Single-Pole	Two-Pole	Three-Pole	Adjustable <sup>②</sup> Thermal, Fixed Magnetic Catalog Number	Four-Pole <sup>③</sup>	Adjustable <sup>②</sup> Thermal, Fixed Magnetic Catalog Number
	Fixed Thermal, Fixed Magnetic Catalog Number	Fixed Thermal, Fixed Magnetic Catalog Number	Fixed Thermal, Fixed Magnetic Catalog Number		Fixed Thermal, Fixed Magnetic Catalog Number	
15	EGH1015FFG	EGH2015FFG	EGH3015FFG	—	EGH4015FFG	—
16	EGH1016FFG	EGH2016FFG	EGH3016FFG	—	EGH4016FFG	—
20	EGH1020FFG	EGH2020FFG	EGH3020FFG	EGH3020AFG	EGH4020FFG	EGH4020AFG
25	EGH1025FFG	EGH2025FFG	EGH3025FFG	EGH3025AFG	EGH4025FFG	EGH4025AFG
30	EGH1030FFG	EGH2030FFG	EGH3030FFG	—	EGH4030FFG	—
32	EGH1032FFG	EGH2032FFG	EGH3032FFG	EGH3032AFG	EGH4032FFG	EGH4032AFG
35	EGH1035FFG	EGH2035FFG	EGH3035FFG	—	EGH4035FFG	—
40	EGH1040FFG	EGH2040FFG	EGH3040FFG	EGH3040AFG	EGH4040FFG	EGH4040AFG
45	EGH1045FFG	EGH2045FFG	EGH3045FFG	—	EGH4045FFG	EGH4050AFG
50	EGH1050FFG	EGH2050FFG	EGH3050FFG	EGH3050AFG	EGH4050FFG	—
60	EGH1060FFG	EGH2060FFG	EGH3060FFG	—	EGH4060FFG	—
63	EGH1063FFG	EGH2063FFG	EGH3063FFG	EGH3063AFG	EGH4063FFG	EGH4063AFG
70	EGH1070FFG	EGH2070FFG	EGH3070FFG	—	EGH4070FFG	—
80	EGH1080FFG	EGH2080FFG	EGH3080FFG	EGH3080AFG	EGH4080FFG	EGH4080AFG
90	EGH1090FFG	EGH2090FFG	EGH3090FFG	—	EGH4090FFG	—
100	EGH1100FFG	EGH2100FFG	EGH3100FFG	EGH3100AFG	EGH4100FFG	EGH4100AFG
125	EGH1125FFG	EGH2125FFG	EGH3125FFG	EGH3125AFG	EGH4125FFG	EGH4125AFG

**Notes**

- ① 16, 32, 63A are not UL listed ratings.
- ② Adjustable thermal are not UL listed.
- ③ Change the fourth digit to 7 for 100% neutral protection. Neutral is on the LH side.

EG-Frame—100/100 Current Limiting (Single-Pole and Two-Pole Unavailable)

## EG-Frame



## EG-Frame — 100/100

Maximum Continuous Amps at 40 °C <sup>①</sup>	Three-Pole		Four-Pole 0% Protected Neutral <sup>③</sup>	
	Fixed Thermal, Fixed Magnetic Catalog Number	Adjustable <sup>②</sup> Thermal, Fixed Magnetic Catalog Number	Fixed Thermal, Fixed Magnetic Catalog Number	Adjustable <sup>②</sup> Thermal, Fixed Magnetic Catalog Number
15	EGC3015FFG	—	EGC7015FFG	—
16	EGC3016FFG	—	EGC7016FFG	—
20	EGC3020FFG	EGC3020AFG	EGC7020FFG	EGC7020AFG
25	EGC3025FFG	EGC3025AFG	EGC7025FFG	EGC7025AFG
30	EGC3030FFG	—	EGC7030FFG	—
32	EGC3032FFG	EGC3032AFG	EGC7032FFG	EGC7032AFG
35	EGC3035FFG	—	EGC7035FFG	—
40	EGC3040FFG	EGC3040AFG	EGC7040FFG	EGC7040AFG
45	EGC3045FFG	—	EGC7045FFG	—
50	EGC3050FFG	EGC3050AFG	EGC7050FFG	EGC7050AFG
60	EGC3060FFG	—	EGC7060FFG	—
63	EGC3063FFG	EGC3063AFG	EGC7063FFG	EGC7063AFG
70	EGC3070FFG	—	EGC7070FFG	—
80	EGC3080FFG	EGC3080AFG	EGC7080FFG	EGC7080AFG
90	EGC3090FFG	—	EGC7090FFG	—
100	EGC3100FFG	EGC3100AFG	EGC7100FFG	EGC7100AFG
125	EGC3125FFG	EGC3125AFG	EGC7125FFG	EGC7125AFG

Molded Case Switches <sup>④</sup>

## Catalog Number

EGK3125KSG

EGK7125KSG

EGK3160KSG

EGK7160KSG

## Notes

- ① 16, 32, 63A are not UL listed ratings.
- ② Adjustable thermal is not UL listed.
- ③ Change the fourth digit to 7 for 100% neutral protection. Neutral is on LH side.
- ④ Molded case switches may open above 1250 A.

#### EG Bolt-On Complete Breaker (Includes Frame, Trip Unit and Mounting Hardware)

2

EG-Frame



#### EG-Frame—18 kAIC at 480 Vac

Maximum Continuous Amps at 40 °C	Single-Pole Fixed Thermal, Fixed Magnetic Catalog Number <sup>①</sup>	Two-Pole Fixed Thermal, Fixed Magnetic Catalog Number <sup>②</sup>	Three-Pole Fixed Thermal, Fixed Magnetic Catalog Number <sup>③</sup>
15	EGB1015FFB	EGB2015FFB	EGB3015FFB
20	EGB1020FFB	EGB2020FFB	EGB3020FFB
25	EGB1025FFB	EGB2025FFB	EGB3025FFB
30	EGB1030FFB	EGB2030FFB	EGB3030FFB
35	EGB1035FFB	EGB2035FFB	EGB3035FFB
40	EGB1040FFB	EGB2040FFB	EGB3040FFB
45	EGB1045FFB	EGB2045FFB	EGB3045FFB
50	EGB1050FFB	EGB2050FFB	EGB3050FFB
60	EGB1060FFB	EGB2060FFB	EGB3060FFB
70	EGB1070FFB	EGB2070FFB	EGB3070FFB
80	EGB1080FFB	EGB2080FFB	EGB3080FFB
90	EGB1090FFB	EGB2090FFB	EGB3090FFB
100	EGB1100FFB	EGB2100FFB	EGB3100FFB
110	EGB1110FFB	EGB2110FFB	EGB3110FFB
125	EGB1125FFB	EGB2125FFB	EGB3125FFB

EG-Frame



#### EG-Frame—35 kAIC at 480 Vac

Maximum Continuous Amps at 40 °C	Single-Pole Fixed Thermal, Fixed Magnetic Catalog Number <sup>①</sup>	Two-Pole Fixed Thermal, Fixed Magnetic Catalog Number <sup>②</sup>	Three-Pole Fixed Thermal, Fixed Magnetic Catalog Number <sup>③</sup>
15	EGS1015FFB	EGS2015FFB	EGS3015FFB
20	EGS1020FFB	EGS2020FFB	EGS3020FFB
25	EGS1025FFB	EGS2025FFB	EGS3025FFB
30	EGS1030FFB	EGS2030FFB	EGS3030FFB
35	EGS1035FFB	EGS2035FFB	EGS3035FFB
40	EGS1040FFB	EGS2040FFB	EGS3040FFB
45	EGS1045FFB	EGS2045FFB	EGS3045FFB
50	EGS1050FFB	EGS2050FFB	EGS3050FFB
60	EGS1060FFB	EGS2060FFB	EGS3060FFB
70	EGS1070FFB	EGS2070FFB	EGS3070FFB
80	EGS1080FFB	EGS2080FFB	EGS3080FFB
90	EGS1090FFB	EGS2090FFB	EGS3090FFB
100	EGS1100FFB	EGS2100FFB	EGS3100FFB
110	EGS1110FFB	EGS2110FFB	EGS3110FFB
125	EGS1125FFB	EGS2125FFB	EGS3125FFB

#### Notes

- ① For bulk pack 24, add suffix BP24 and order quantities of 24.
- ② For bulk pack 12, add suffix BP12 and order quantities of 12.
- ③ For bulk pack 8, add suffix BP8 and order quantities of 8.

## EG-Frame



## EG-Frame—65 kAIC at 480 Vac

Maximum Continuous Amps at 40 °C	Single-Pole Fixed Thermal, Fixed Magnetic Catalog Number <sup>①</sup>	Two-Pole Fixed Thermal, Fixed Magnetic Catalog Number <sup>②</sup>	Three-Pole Fixed Thermal, Fixed Magnetic Catalog Number <sup>③</sup>
15	EGH1015FFB	EGH2015FFB	EGH3015FFB
20	EGH1020FFB	EGH2020FFB	EGH3020FFB
25	EGH1025FFB	EGH2025FFB	EGH3025FFB
30	EGH1030FFB	EGH2030FFB	EGH3030FFB
35	EGH1035FFB	EGH2035FFB	EGH3035FFB
40	EGH1040FFB	EGH2040FFB	EGH3040FFB
45	EGH1045FFB	EGH2045FFB	EGH3045FFB
50	EGH1050FFB	EGH2050FFB	EGH3050FFB
60	EGH1060FFB	EGH2060FFB	EGH3060FFB
70	EGH1070FFB	EGH2070FFB	EGH3070FFB
80	EGH1080FFB	EGH2080FFB	EGH3080FFB
90	EGH1090FFB	EGH2090FFB	EGH3090FFB
100	EGH1100FFB	EGH2100FFB	EGH3100FFB
110	EGH1110FFB	EGH2110FFB	EGH3110FFB
125	EGH1125FFB	EGH2125FFB	EGH3125FFB

## Load Terminals

Maximum Breaker Amps	Terminal, Body Material	Wire Type	Metric Wire Range mm <sup>2</sup>	AWG Wire Range	(Package of Three Terminals) Catalog Number
<b>Standard Cu/Al Pressure Type Terminals</b>					
15–50	Aluminum	Cu/Al	2.5–50	#14–1/0	3TA125EF
60–125	Aluminum	Cu/Al	16–70	#6–3/0	3TA150EF

**Notes**

- ① For bulk pack 24, add suffix BP24 and order quantities of 24.  
 ② For bulk pack 12, add suffix BP12 and order quantities of 12.  
 ③ For bulk pack 8, add suffix BP8 and order quantities of 8.

#### Accessories Selection Guide and Ordering Information

2

#### EG-Frame

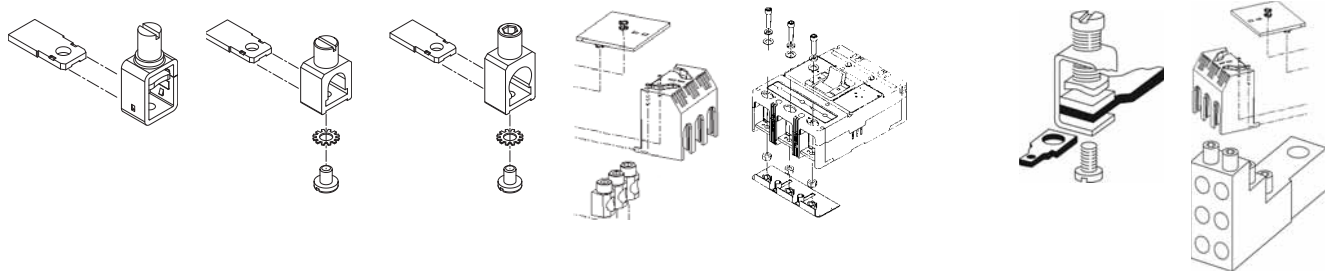

3T125EF	3TA125EF	3TA150EF	3TA160EFK	EF2RTWK, Two-Pole–Metric EF3RTWK, Three-Pole–Metric EF4RTWK, Four-Pole–Metric EF2RTDK, Two-Pole–Imperial EF3RTDK, Three-Pole–Imperial EF4RTDK, Four-Pole–Imperial	Control Wire Terminal Kit GCWTK	Multiwire Connectors
---------	----------	----------	-----------	--	---------------------------------------	-------------------------

#### Line and Load Terminals

Maximum Breaker Amps	Terminal Body Material	Wire Type	Metric Wire Range mm <sup>2</sup>	AWG Wire Range	(Package of Three Terminals) Catalog Number
<b>Standard Cu/Al Pressure Type Terminals</b>					
125	Steel	Al	4–6	#14-3/0	3T125EF ①
125	Steel	Cu	2.5–95	#14-3/0	3T125EF ①
125	Aluminum	Cu/Al	2.5–50	#14-1/0	3TA125EF
160	Aluminum	Cu/Al	16–70	#6-3/0	3TA150EF
160	Aluminum	Cu/Al	35–120	#3-250	3TA160EFK
160	Aluminum	Cu/Al	35–120	#3-250	4TA160EFK ②

EG-Frame circuit breakers and molded case switches have line and load terminals as standard equipment.

Insert collar enclosing conductor as shown. Locate nut on top of conductor and tighten securely with screw and washer.

**Caution:** Collar must surround conductor.

Insert collar enclosing conductor and center on extrusion. Tighten securely with screw and washer. Endcap kits are used on the E-Frame breaker line side to connect busbar or similar electrical connections. Includes hardware.

#### Notes

- ① Standard line and load terminals.
- ② Four-pole kit with four terminals.

### Control Wire Terminal Kit

	Catalog Number
Control wire terminal kit	5652B38G01
Package of 12—priced individually	

For use with steel or stainless steel standard line and load terminals only.

### Interphase Barriers

	Catalog Number
Interphase barriers	EIPBK
Package of 12—priced individually	

The interphase barrier is available for extended insulation between circuit breaker poles. Specify quantity when ordering.

### Base Mounting Hardware—DIN Rail Mounting

	Catalog Number
DIN rail adapter—single-pole	EF1DIN
DIN rail adapter—two-pole	EGDIN
DIN rail adapter—three- or four-pole	EF34DIN
Metal DIN rail adapter—three-pole	EGDDIN

Metric base mounting hardware is included with a circuit breaker or molded case switch. (Included with breaker.) If required separately, order S/N 8703C80G08.

**Note:** English mounting hardware kit can be supplied separate. Catalog number is **BMHE #6-32** x 3 inches for two-, three- and four-pole. Single-pole mounting hardware metric order **8703C80G11**. English hardware **8703C80G12**. Both sold in quantities of 100.

### Terminal Shields

The terminal shield is available for line terminal areas in three- and four-pole circuit breakers. Special terminal shields are also available for use when an electrical (solenoid) operator is mounted on the circuit breaker. The standard style number by pole for each terminal shield is for a package of 10 and is priced per each package. Special terminal shields are packaged individually.

### Terminal Shields—IP30 Protection

Number of Poles	Catalog Number
3	EFTS3K
4	EFTS4K

### Terminal End Covers (Gas Barrier)

The terminal end cover is available for three-pole circuit breakers only. Two conductor opening sizes are available. Specify quantity (one per circuit breaker) when ordering.

### Terminal End Covers

Conductor Opening Diameter Inches (mm)	Catalog Number
6.35 (0.25)	EEC3K
10.41 (0.41)	EEC4K

### Multiwire Connectors

Field-installed multiwire connectors for the load side (OFF) end terminals. They are used to distribute the load from the circuit breaker to multiple devices without the use of separate distribution terminal blocks.

Multiwire lug kits include mounting hardware, terminal shield insulators and tin-plated aluminum connectors to replace three mechanical load lugs. UL listed as used on the load side (OFF) end.

### EG-Frame Multiwire Connectors Ordering Information (Package of 3) <sup>Ⓢ</sup>

Maximum Amperes	Wires per Terminal	Wire Size Range AWG Cu	Kit Catalog Number
125	3	14-2	3TA125E3K
125	6	14-6	3TA125E6K

#### Note

<sup>Ⓢ</sup> For four-pole kit, change "3" at beginning of catalog number to "4."

### Accessories

2

#### Allowable Accessory Combinations

Different combinations of accessories can be supplied, depending on the types of accessories and the number of poles in the circuit breaker.

#### EG-Frame Accessories

Description	Reference Page	Single-Pole	Two-Pole		Three-Pole			Four-Pole			Neutral
		Center	Left	Right	Left	Center	Right	Left	Center	Right	
<b>Internal Accessories (Only one internal accessory per pole)</b>											
Alarm lockout (Make/Break)	V4-T2-109	—	—	■	—	—	■	—	—	■	—
Alarm lockout (2Make/2Break)	V4-T2-109	—	—	■	—	—	■	—	—	■	—
Auxiliary switch (1A, 1B)	V4-T2-109	—	—	■	—	—	■	—	—	■	—
Auxiliary switch (2A, 2B)	V4-T2-109	—	—	■	—	—	■	—	—	■	—
Auxiliary switch and alarm switch combination	V4-T2-109	—	—	■	—	—	■	—	—	■	—
Shunt trip—standard	V4-T2-109	—	—	—	■	—	—	■	—	—	—
Undervoltage release mechanism	V4-T2-110	—	—	—	■	—	—	■	—	—	—
<b>External Accessories</b>											
End cap kit	V4-T2-25	—	●	●	●	●	●	●	●	●	●
Control wire terminal kit	V4-T2-25	●	●	●	●	●	●	●	●	●	●
Multiwire connectors	V4-T2-25	●	●	●	●	●	●	●	●	●	●
Base mounting hardware	V4-T2-25	●	●	●	●	●	●	●	●	●	●
Terminal shields	V4-T2-25	●	●	●	●	●	●	●	●	●	●
Terminal end covers	V4-T2-25	—	—	—	●	●	●	—	—	—	—
Interphase barriers	V4-T2-25	—	●	●	●	●	●	●	●	●	●
Non-padlockable handle block	V4-T2-107	■	■	—	—	■	—	—	■	—	—
Snap-on padlockable handle lock hasp	V4-T2-107	■	■	—	—	■	—	—	■	—	—
Padlockable handle lock hasp	V4-T2-107	—	—	■	□	—	□	□	—	□	—
Walking beam interlock—requires two breakers	V4-T2-107	—	—	—	●	●	●	●	●	●	●
Plug-in adapters	V4-T2-107	—	●	●	●	●	●	●	●	●	●
Electrical operator	V4-T2-107	—	—	—	●	●	●	—	—	—	—
Handle mechanisms	V4-T2-420	—	—	—	●	●	●	—	—	—	—
<b>Modifications (Refer to Eaton)</b>											
Moisture fungus treatment	V4-T2-105	●	●	●	●	●	●	●	●	●	●
Freeze-tested circuit breakers	—	●	●	●	●	●	●	●	●	●	●
Marine/naval application, UL 489 Supplement SA and SB	—	●	●	●	●	●	●	●	●	●	●

#### Legend

- Applicable in indicated pole position
- May be mounted on left or right pole—not both
- Accessory available/modification available

**Technical Data and Specifications**

**UL 489/IEC 60947-2 Interrupting Capacity (Symmetrical Amperes) (kA) Ratings**

Circuit Breaker Type	Number of Poles	Volts AC (50/60 Hz)										Volts DC <sup>①</sup>					
		220–240					380–415					690 <sup>②</sup>		125		250 <sup>③④</sup>	
		120	I <sub>CU</sub>	I <sub>CS</sub>	277	347	I <sub>CU</sub>	I <sub>CS</sub>	480	600Y/347	I <sub>CU</sub>	I <sub>CS</sub>	I <sub>CU</sub>	I <sub>CS</sub>	I <sub>CU</sub>	I <sub>CS</sub>	
EGB125	1	35	25	25	18	—	—	—	—	—	—	—	—	10	10	—	—
	2, 3, 4	—	25	25	—	—	18	18	18	—	—	—	—	—	—	10	10
EGE125	2, 3, 4	—	35	35	—	—	25	25	25	18	—	—	—	—	—	10	10
	1	100	85	43	35	22	—	—	—	—	—	—	—	35	35	—	—
EGS125	2, 3, 4	—	85	43	—	—	40	30	35	22	—	—	—	—	—	35	35
	1	200	100	50	65	25	—	—	—	—	—	—	—	42	42	—	—
EGH125	2, 3, 4	—	100	50	—	—	70	35	65	25	—	—	—	—	—	42	42
	3, 4	—	200	200	—	—	100	100	100	35	—	—	—	—	—	42	42
EGC125 <sup>⑤</sup>	3, 4	—	200	200	—	—	100	100	100	35	—	—	—	—	—	42	42
	3, 4	—	25	25	—	—	18	18	18	—	—	—	—	—	—	10	10
EGB160 <sup>②</sup>	3, 4	—	25	25	—	—	18	18	18	—	—	—	—	—	—	10	10
	3, 4	—	35	35	—	—	25	25	25	18	—	—	—	—	—	10	10
EGE160 <sup>②</sup>	3, 4	—	35	35	—	—	25	25	25	18	—	—	—	—	—	10	10
	3, 4	—	85	43	—	—	40	30	35	22	—	—	—	—	—	35	35

**UL 489 Current Limiting Data**

Frame	Circuit	I <sub>p</sub> (kA)	I <sup>2</sup> T (10 <sup>6</sup> A <sup>2</sup> S)
EGC	240 V/200 kA	24.5	0.6310
EGC	480 V/100 kA	24.5	0.6310
EGC	600 Y/35 kA	20.0	1.392

**Dimensions and Weights**

Approximate Dimensions in Inches (mm)

**EG-Frame**

Number of Poles	Width	Height	Depth
1	1.00 (25.4)	5.50 (139.7)	2.99 (75.9)
2	2.00 (50.8)	5.50 (139.7)	2.99 (75.9)
3	3.00 (76.2)	5.50 (139.7)	2.99 (75.9)
4	4.00 (101.6)	5.50 (139.7)	2.99 (75.9)

**EG-Frame**

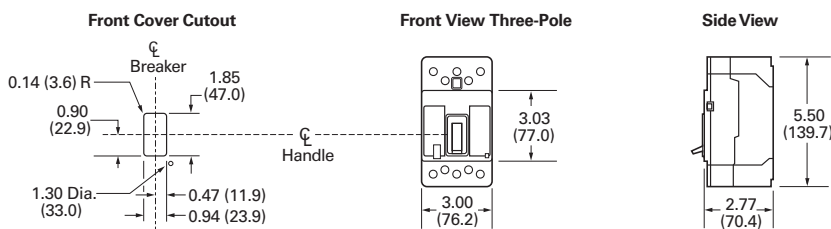

Approximate Shipping Weight in Lbs (kg)

**EG-Frame**

EG Breaker Type	Number of Poles			
	1	2	3	4
EGB125	1.5 (0.68)	2.0 (0.91)	3.0 (1.36)	4.9 (1.82)

**Notes**

- ① DC ratings apply to substantially non-inductive circuits.
- ② IEC only.
- ③ Two-pole circuit breaker, or two poles of three-pole circuit breaker.
- ④ Time constant is 3 milliseconds minimum at 10 kA and 8 milliseconds minimum at 42 kA.
- ⑤ Current limiting per UL 489.

# 2.2

## Molded Case Circuit Breakers

### Series G

#### EG-Frame With Earth Leakage Module

2

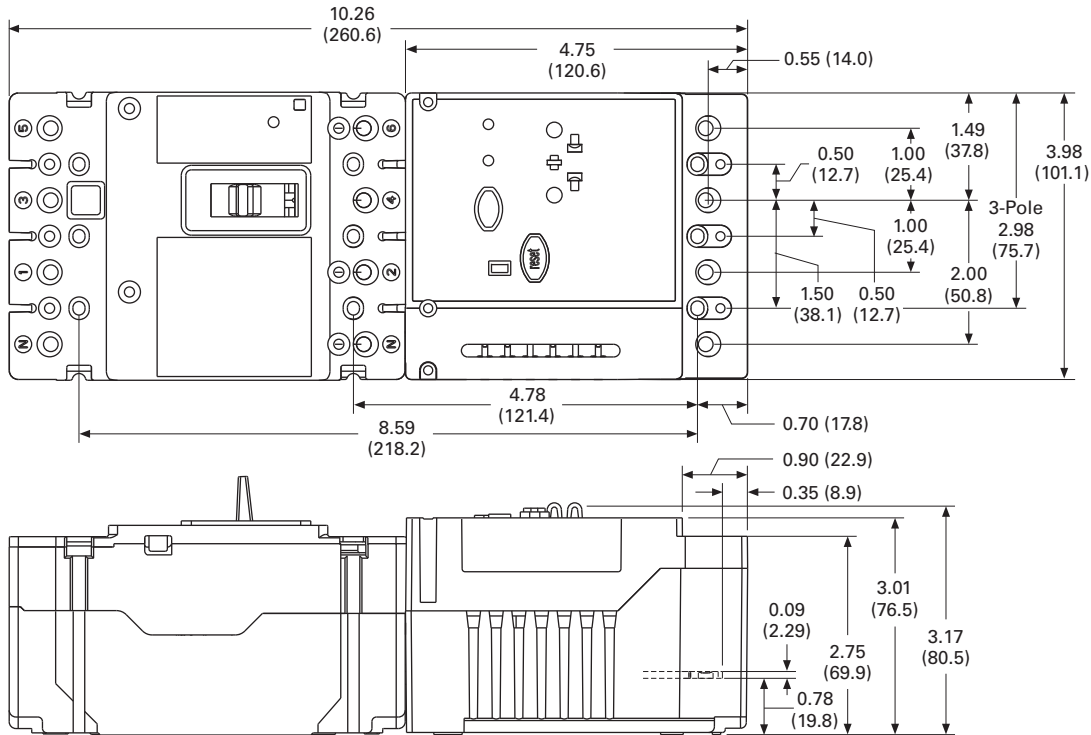

#### EG-Frame With Current Limiter Module

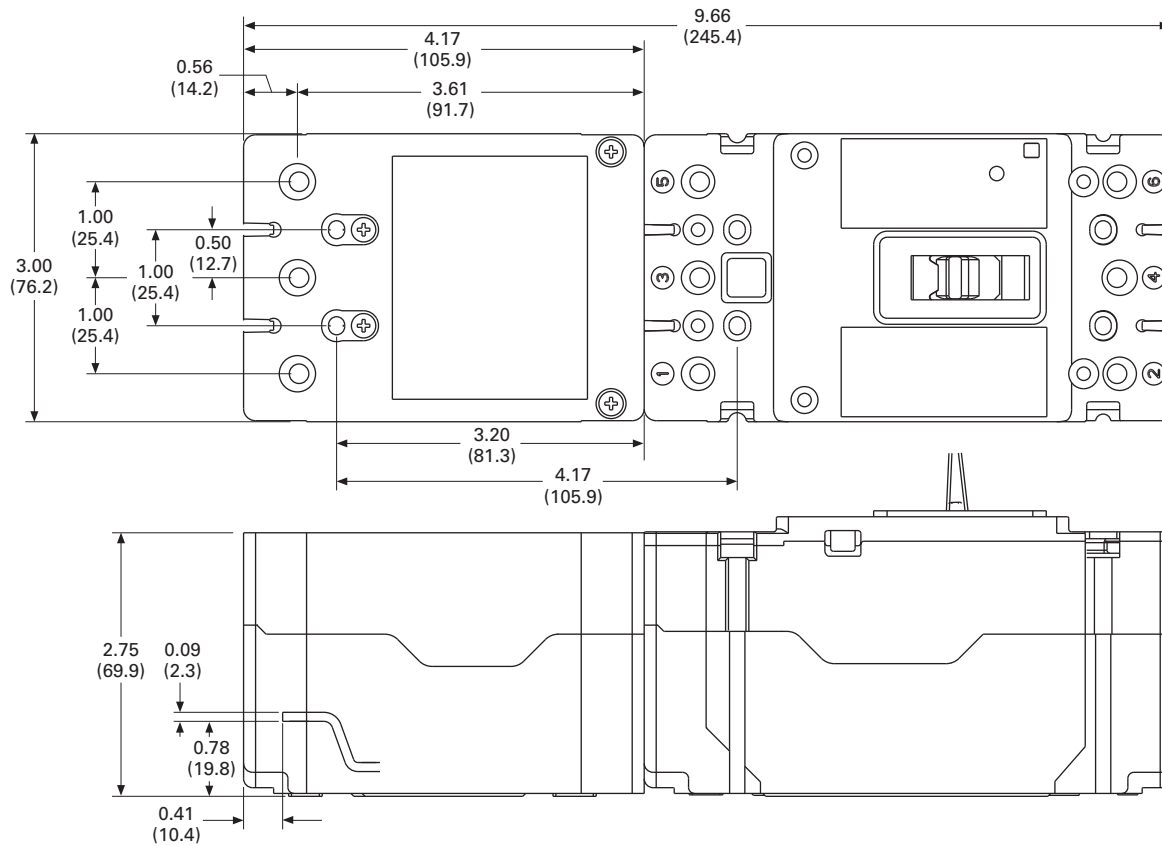

**JG-Frame (63–250 Amperes)****JG-Frame (63–250 Amperes)****Product Description**

JG breaker is HACR rated.

**Contents****Description**

	<i>Page</i>
EG-Frame (15–125 Amperes) . . . . .	<b>V4-T2-15</b>
JG-Frame (63–250 Amperes)	
Catalog Number Selection . . . . .	<b>V4-T2-30</b>
Product Selection . . . . .	<b>V4-T2-31</b>
Accessories . . . . .	<b>V4-T2-42</b>
Technical Data and Specifications . . . . .	<b>V4-T2-43</b>
Dimensions and Weights . . . . .	<b>V4-T2-45</b>
LG-Frame (250–630 Amperes) . . . . .	<b>V4-T2-47</b>
NG-Frame (320–1200 Amperes) . . . . .	<b>V4-T2-65</b>
RG-Frame (800–2500 Amperes) . . . . .	<b>V4-T2-74</b>
Motor Circuit Protectors (MCP) . . . . .	<b>V4-T2-85</b>
Motor Protector Circuit Breakers (MPCB) . . . . .	<b>V4-T2-89</b>
30 mA Ground Fault (Earth Leakage) Module . . . . .	<b>V4-T2-92</b>
Current Limiting Circuit Breaker Module . . . . .	<b>V4-T2-96</b>
High Instantaneous Circuit Breaker for	
Selective Coordination . . . . .	<b>V4-T2-101</b>
Special Features and Accessories . . . . .	<b>V4-T2-104</b>
Motor Operators . . . . .	<b>V4-T2-112</b>
Plug-In Blocks . . . . .	<b>V4-T2-114</b>
Drawout Cassette . . . . .	<b>V4-T2-115</b>

# 2.2

## Molded Case Circuit Breakers

### Series G

#### Catalog Number Selection

This information is presented only as an aid to understanding catalog numbers. It is not to be used to build catalog numbers for circuit breakers or trip units.

2

#### Series G—JG-Frame (63–250 Amperes)

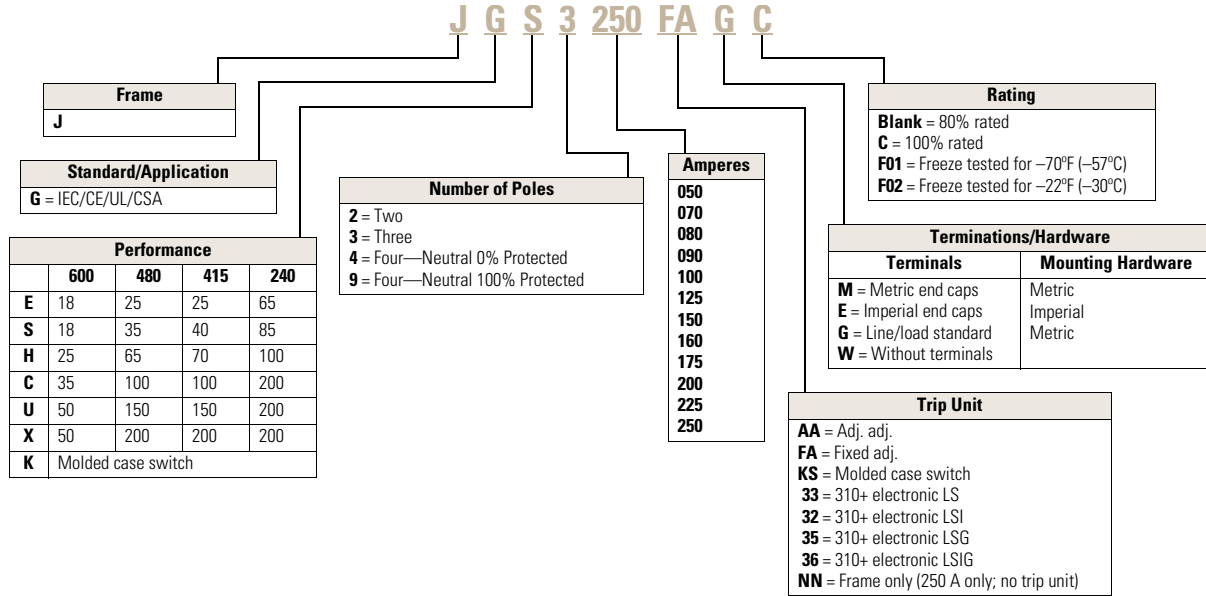

#### Trip Unit

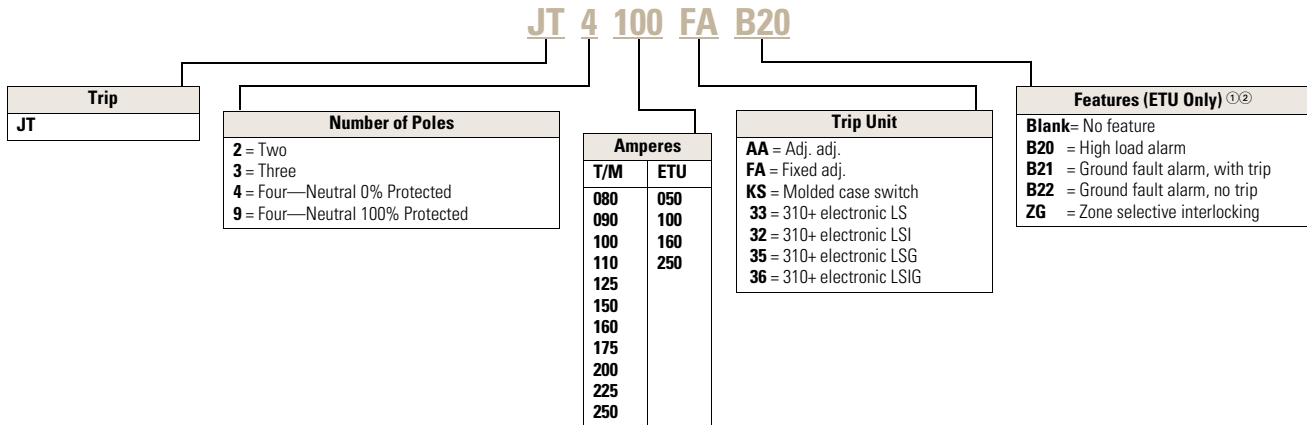

#### Notes

- ① Bxx features cannot be combined with other Bxx features.
- ② B21 and B22 available with LSG and LSIG trip units.

## Product Selection

**Complete Breaker (Includes Frame, Trip Unit, Standard Terminals and Mounting Hardware)—IC Rating at 415/480 Volts**

## JG-Frame



## JG-Frame—IEC/CE/UL/CSA—25/25

Maximum Continuous Amperes	Magnetic Range	Two-Pole	Three-Pole	Adjustable Thermal, Adjustable Magnetic <sup>①</sup>	Four-Pole 0% <sup>②</sup>	Adjustable Thermal, Adjustable Magnetic <sup>①</sup>
		Fixed Thermal, Adjustable Magnetic	Fixed Thermal, Adjustable Magnetic		Fixed Thermal, Adjustable Magnetic	
		Catalog Number	Catalog Number	Catalog Number	Catalog Number	Catalog Number
70	350–700	JGE2070FAG	JGE3070FAG	—	JGE4070FAG	—
90	450–900	JGE2090FAG	JGE3090FAG	—	JGE4090FAG	—
100	500–1000	JGE2100FAG	JGE3100FAG	JGE3100AAG	JGE4100FAG	JGE4100AAG
125	625–1250	JGE2125FAG	JGE3125FAG	JGE3125AAG	JGE4125FAG	JGE4125AAG
150	750–1550	JGE2150FAG	JGE3150FAG	—	JGE4150FAG	—
160	800–1600	—	—	JGE3160AAG	—	JGE4160AAG
175	875–1750	JGE2175FAG	JGE3175FAG	—	JGE4175FAG	—
200	1000–2000	JGE2200FAG	JGE3200FAG	JGE3200AAG	JGE4200FAG	JGE4200AAG
225	1125–2250	JGE2225FAG	JGE3225FAG	—	JGE4225FAG	—
250	1250–2500	JGE2250FAG	JGE3250FAG	JGE3250AAG	JGE4250FAG	JGE4250AAG

## JG-Frame



## JG-Frame—IEC/CE/UL/CSA—40/35, Two-Pole

Maximum Continuous Amperes	Magnetic Range	Two-Pole	Three-Pole	Adjustable Thermal, Adjustable Magnetic <sup>①</sup>	Four-Pole 0% <sup>②</sup>	Adjustable Thermal, Adjustable Magnetic <sup>①</sup>
		Fixed Thermal, Adjustable Magnetic	Fixed Thermal, Adjustable Magnetic		Fixed Thermal, Adjustable Magnetic	
		Catalog Number	Catalog Number	Catalog Number	Catalog Number	Catalog Number
70	350–700	JGS2070FAG	JGS3070FAG	—	JGS4070FAG	—
90	450–900	JGS2090FAG	JGS3090FAG	—	JGS4090FAG	—
100	500–1000	JGS2100FAG	JGS3100FAG	JGS3100AAG	JGS4100FAG	JGS4100AAG
125	625–1250	JGS2125FAG	JGS3125FAG	JGS3125AAG	JGS4125FAG	JGS4125AAG
150	750–1550	JGS2150FAG	JGS3150FAG	—	JGS4150FAG	—
160	800–1600	—	—	JGS3160AAG	—	JGS4160AAG
175	875–1750	JGS2175FAG	JGS3175FAG	—	JGS4175FAG	—
200	1000–2000	JGS2200FAG	JGS3200FAG	JGS3200AAG	JGS4200FAG	JGS4200AAG
225	1125–2250	JGS2225FAG	JGS3225FAG	—	JGS4225FAG	—
250	1250–2500	JGS2250FAG	JGS3250FAG	JGS3250AAG	JGS4250FAG	JGS4250AAG

## Notes

- <sup>①</sup> EC-EN 60947-2 only. Adjustment is 0.8 and 1.0.  
<sup>②</sup> 9 for 0–100% neutral protection. Neutral is on LH side.

JG-Frame



## JG-Frame—IEC/CE/UL/CSA—70/65

Maximum Continuous Amperes	Magnetic Range	Two-Pole Fixed Thermal, Adjustable Magnetic Catalog Number	Three-Pole Fixed Thermal, Adjustable Magnetic Catalog Number	Adjustable Thermal, Fixed Magnetic <sup>①</sup> Catalog Number	Four-Pole 0% <sup>②</sup> Fixed Thermal, Adjustable Magnetic Catalog Number	Adjustable Thermal, Fixed Magnetic <sup>①</sup> Catalog Number
70	350–700	JGH2070FAG	JGH3070FAG	—	JGH4070FAG	—
90	450–900	JGH2090FAG	JGH3090FAG	—	JGH4090FAG	—
100	500–1000	JGH2100FAG	JGH3100FAG	JGH3100AAG	JGH4100FAG	JGH4100AAG
125	625–1250	JGH2125FAG	JGH3125FAG	JGH3125AAG	JGH4125FAG	JGH4125AAG
150	750–1550	JGH2150FAG	JGH3150FAG	—	JGH4150FAG	—
160	800–1600	—	—	JGH3160AAG	—	JGH4160AAG
175	875–1750	JGH2175FAG	JGH3175FAG	—	JGH4175FAG	—
200	1000–2000	JGH2200FAG	JGH3200FAG	JGH3200AAG	JGH4200FAG	JGH4200AAG
225	1125–2250	JGH2225FAG	JGH3225FAG	—	JGH4225FAG	—
250	1250–2500	JGH2250FAG	JGH3250FAG	JGH3250AAG	JGH4250FAG	JGH4250AAG

**Notes**

<sup>①</sup> EC-EN 60947-2 only. Adjustment is 0.8 and 1.0.

<sup>②</sup> 9 for 0–100% neutral protection. Neutral is on LH side.

Two-Pole not available in IEC/CE/UL/CSA 100/100, 150/150

#### JG-Frame



#### JG-Frame—IEC/CE/UL/CSA—100/100, Current Limiting

Maximum Continuous Amperes	Magnetic Range	Three-Pole		Four-Pole 0% <sup>②</sup>	
		Fixed Thermal, Adjustable Magnetic Catalog Number	Adjustable Thermal, Adjustable Magnetic <sup>①</sup> Catalog Number	Fixed Thermal, Adjustable Magnetic Catalog Number	Adjustable Thermal, Adjustable Magnetic <sup>①</sup> Catalog Number
70	350–700	JGC3070FAG	—	JGC4070FAG	—
80	400–800	—	JGC3080AAG	—	JGC4080AAG
90	450–900	JGC3090FAG	—	JGC4090FAG	—
100	500–1000	JGC3100FAG	JGC3100AAG	JGC4100FAG	JGC4100AAG
125	625–1250	JGC3125FAG	JGC3125AAG	JGC4125FAG	JGC4125AAG
150	750–1550	JGC3150FAG	—	JGC4150FAG	—
160	800–1600	—	JGC3160AAG	—	JGC4160AAG
175	875–1750	JGC3175FAG	—	JGC4175FAG	—
200	1000–2000	JGC3200FAG	JGC3200AAG	JGC4200FAG	JGC4200AAG
225	1125–2250	JGC3225FAG	—	JGC4225FAG	—
250	1250–2500	JGC3250FAG	JGC3250AAG	JGC4250FAG	JGC4250AAG

#### JG-Frame



#### JG-Frame—IEC/CE/UL/CSA—150/150, Current Limiting

Maximum Continuous Amperes	Magnetic Range	Three-Pole		Four-Pole 0% <sup>②</sup>	
		Fixed Thermal, Adjustable Magnetic Catalog Number	Adjustable Thermal, Adjustable Magnetic <sup>①</sup> Catalog Number	Fixed Thermal, Adjustable Magnetic Catalog Number	Adjustable Thermal, Adjustable Magnetic <sup>①</sup> Catalog Number
70	350–700	JGU3070FAG	—	JGU4070FAG	—
80	400–800	—	JGU3080AAG	—	JGU4080AAG
90	450–900	JGU3090FAG	—	JGU4090FAG	—
100	500–1000	JGU3100FAG	JGU3100AAG	JGU4100FAG	JGU4100AAG
125	625–1250	JGU3125FAG	JGU3125AAG	JGU4125FAG	JGU4125AAG
150	750–1550	JGU3150FAG	—	JGU4150FAG	—
160	800–1600	—	JGU3160AAG	—	JGU4160AAG
175	875–1750	JGU3175FAG	—	JGU4175FAG	—
200	1000–2000	JGU3200FAG	JGU3200AAG	JGU4200FAG	JGU4200AAG
225	1125–2250	JGU3225FAG	—	JGU4225FAG	—
250	1250–2500	JGU3250FAG	JGU3250AAG	JGU4250FAG	JGU4250AAG

#### Notes

- ① EC-EN 60947-2 only. Adjustment is 0.8 and 1.0.  
 ② 9 for 0–100% neutral protection. Neutral is on LH side.

# 2.2

## Molded Case Circuit Breakers

### Series G

Two-Pole not available in IEC/CE/UL/CSA 200/200

2

#### JG-Frame



#### JG-Frame—IEC/CE/UL/CSA 200/200, Current Limiting

Maximum Continuous Amperes	Magnetic Range	Three-Pole		Four-Pole <sup>②</sup>	
		Fixed Thermal, Adjustable Magnetic Catalog Number	Adjustable Thermal, Adjustable Magnetic <sup>①</sup> Catalog Number	Fixed Thermal, Adjustable Magnetic Catalog Number	Adjustable Thermal, Adjustable Magnetic <sup>①</sup> Catalog Number
70	350–700	JGX3070FAG	—	JGX4070FAG	—
80	400–800	—	JGX3080AAG	—	JGX4080AAG
90	450–900	JGX3090FAG	—	JGX4090FAG	—
100	500–1000	JGX3100FAG	JGX3100AAG	JGX4100FAG	JGX4100AAG
125	625–1250	JGX3125FAG	JGX3125AAG	JGX4125FAG	JGX4125AAG
150	750–1550	JGX3150FAG	—	JGX4150FAG	—
160	800–1600	—	JGX3160AAG	—	JGX4160AAG
175	875–1750	JGX3175FAG	—	JGX4175FAG	—
200	1000–2000	JGX3200FAG	JGX3200AAG	JGX4200FAG	JGX4200AAG
225	1125–2250	JGX3225FAG	—	JGX4225FAG	—
250	1250–2500	JGX3250FAG	JGX3250AAG	JGX4250FAG	JGX4250AAG

#### Molded Case Switches <sup>③</sup>

Catalog Number

JGK3250KSG

JGK7250KSG

#### Notes

- ① EC-EN 60947-2 only. Adjustment is 0.8 and 1.0.
- ② 9 for 0–100% neutral protection. Neutral is on LH side.
- ③ Molded case switches will trip above 2500 amperes.

## Frame—IC Rating at 415/480 Volts

Maximum Amperes	Two-Pole Catalog Number	Three-Pole Catalog Number	Four-Pole 0% Catalog Number
<b>25/25</b>			
250	JGE2250NN	JGE3250NN	JGE4250NN
<b>40/35</b>			
250	JGS2250NN	JGS3250NN	JGS4250NN
<b>70/65</b>			
250	JGH2250NN	JGH3250NN	JGH4250NN
<b>100/100 Current Limiting Per UL 489</b>			
250	—	JGC3250NN	JGC4250NN
<b>150/150 Current Limiting Per UL 489</b>			
250	—	JGU3250NN	JGU4250NN
<b>200/200 Current Limiting Per UL 489</b>			
250	—	JGX3250NN	JGX4250NN
<b>25/25 100% Rated Per UL 489 <sup>②</sup></b>			
250	—	JGE3250NNC	—
<b>40/35 100% Rated Per UL 489 <sup>②</sup></b>			
250	—	JGS3250NNC	—
<b>70/65 100% Rated Per UL 489 <sup>②</sup></b>			
250	—	JGH3250NNC	—

## Thermal-Magnetic Trip Unit

Ampere Rating	Range	Catalog Number		Range	Catalog Number		Catalog Number
70	350–700	JT2070FA	JT3070FA	—	—	JT4070FA	—
80	400–800	—	JT3080FA	JT3080AA <sup>③</sup>	64–100	—	JT4080AA <sup>③</sup>
90	450–900	JT2090FA	JT3090FA	—	—	JT4090FA	—
100	500–1000	JT2100FA	JT3100FA	JT3100AA <sup>③</sup>	80–100	JT4100FA	JT4100AA <sup>③</sup>
125	625–1250	JT2125FA	JT3125FA	JT3125AA <sup>③</sup>	100–125	JT4125FA	JT4125AA <sup>③</sup>
150	750–1550	JT2150FA	JT3150FA	—	—	JT4150FA	—
160	800–1600	—	—	JT3160AA <sup>③</sup>	128–160	—	JT4160AA <sup>③</sup>
175	875–1750	JT2175FA	JT3175FA	—	—	JT4175FA	—
200	1000–2000	JT2200FA	JT3200FA	JT3200AA <sup>③</sup>	160–200	JT4200FA	JT4200AA <sup>③</sup>
225	1125–2250	JT2225FA	JT3225FA	—	—	JT4225FA	—
250	1250–2500	JT2250FA	JT3250FA	JT3250AA <sup>③</sup>	200–250	JT4250FA	JT4250AA <sup>③</sup>

## Notes

- ① Standard line and load terminals.
- ② Components—100% rated frame.
- ③ Adjustable thermal trip units are typically used in IEC markets and are not UL or CSA listed.

**310+ Electronic Trip Units**

See 310+ adjustability specifications on **Page V4-T2-44**.

2

**JG 310+ Electronic Trip Units**

Ampere Rating	LS Catalog Number	LSI Catalog Number	LSG Catalog Number	LSIG Catalog Number	Neutral CT for LSG and LSIG <sup>①</sup> Catalog Number
<b>Three-Pole</b>					
50	JT305033	JT305032	JT305035	JT305036	JGFCT050
100	JT310033	JT310032	JT310035	JT310036	JGFCT100
160	JT316033	JT316032	JT316035	JT316036	JGFCT160
250	JT325033	JT325032	JT325035	JT325036	JGFCT250
<b>Four-Pole <sup>②③</sup></b>					
50	JT405033	JT405032	JT405035	JT405036	—
100	JT410033	JT410032	JT410035	JT410036	—
160	JT416033	JT416032	JT416035	JT416036	—
250	JT425033	JT425032	JT425035	JT425036	—

**310+ Electronic Trip Unit Accessories**

Description	Catalog Number
Electronic portable test kit	MTST230V
Trip unit tamper protection wire seal	5108A03H01
External neutral sensor (250 A)	JGFCT250
External neutral sensor (160 A)	JGFCT160
External neutral sensor (100 A)	JGFCT100
External neutral sensor (80 A)	JGFCT050
Breaker-mount cause-of-trip indication	TRIP-LED
Breaker-mount ammeter module	DIGIVIEW
Remote-mount ammeter module	DIGIVIEWR06

**Notes**

- ① For use on a three-pole breaker used in a four-wire system if ground fault protection for the neutral is required.
- ② Neutral protection 4 = 0%, 7 = 100% electronic trip unit neutral protection is not adjustable.
- ③ Four-pole breakers with LSG and LSIG trip units are only available with 0% neutral protection.

**Complete Breaker with 310+ Electronic Trip Units**See 310+ adjustability specifications on **Page V4-T2-44**.**IEC/UL/CSA—25/25**

Ampere Rating	LS Catalog Number	LSI Catalog Number	LSG Catalog Number	LSIG Catalog Number	Neutral CT for LSG and LSIG <sup>①</sup> Catalog Number
<b>Three-Pole</b>					
50	JGE305033G	JGE305032G	JGE305035G	JGE305036G	JGFCT050
100	JGE310033G	JGE310032G	JGE310035G	JGE310036G	JGFCT100
160	JGE316033G	JGE316032G	JGE316035G	JGE316036G	JGFCT160
250	JGE325033G	JGE325032G	JGE325035G	JGE325036G	JGFCT250
<b>Four-Pole <sup>②</sup></b>					
50	JGE405033G	JGE405032G	JGE405035G	JGE405036G	—
100	JGE410033G	JGE410032G	JGE410035G	JGE410036G	—
160	JGE416033G	JGE416032G	JGE416035G	JGE416036G	—
250	JGE425033G	JGE425032G	JGE425035G	JGE425036G	—

**IEC/UL/CSA—40/35**

Ampere Rating	LS Catalog Number	LSI Catalog Number	LSG Catalog Number	LSIG Catalog Number	Neutral CT for LSG and LSIG <sup>①</sup> Catalog Number
<b>Three-Pole</b>					
50	JGS305033G	JGS305032G	JGS305035G	JGS305036G	JGFCT050
100	JGS310033G	JGS310032G	JGS310035G	JGS310036G	JGFCT100
160	JGS316033G	JGS316032G	JGS316035G	JGS316036G	JGFCT160
250	JGS325033G	JGS325032G	JGS325035G	JGS325036G	JGFCT250
<b>Four-Pole <sup>②③</sup></b>					
50	JGS405033G	JGS405032G	JGS405035G	JGS405036G	—
100	JGS410033G	JGS410032G	JGS410035G	JGS410036G	—
160	JGS416033G	JGS416032G	JGS416035G	JGS416036G	—
250	JGS425033G	JGS425032G	JGS425035G	JGS425036G	—

**IEC/UL/CSA—70/65**

Ampere Rating	LS Catalog Number	LSI Catalog Number	LSG Catalog Number	LSIG Catalog Number	Neutral CT for LSG and LSIG <sup>①</sup> Catalog Number
<b>Three-Pole</b>					
50	JGH305033G	JGH305032G	JGH305035G	JGH305036G	JGFCT050
100	JGH310033G	JGH310032G	JGH310035G	JGH310036G	JGFCT100
160	JGH316033G	JGH316032G	JGH316035G	JGH316036G	JGFCT160
250	JGH325033G	JGH325032G	JGH325035G	JGH325036G	JGFCT250
<b>Four-Pole <sup>②</sup></b>					
50	JGH405033G	JGH405032G	JGH405035G	JGH405036G	—
100	JGH410033G	JGH410032G	JGH410035G	JGH410036G	—
160	JGH416033G	JGH416032G	JGH416035G	JGH416036G	—
250	JGH425033G	JGH425032G	JGH425035G	JGH425036G	—

**Notes**<sup>①</sup> Required for four-wire systems if neutral protection is required.<sup>②</sup> Neutral protection 4 = 0%, 7 = 100% electronic trip unit neutral protection is not adjustable.<sup>③</sup> Four-pole breakers with LSG and LSIG trip units are only available with 0% neutral protection.

## IEC/UL/CSA—100/100, Current Limiting Per UL 489

Ampere Rating	LS Catalog Number	LSI Catalog Number	LSG Catalog Number	LSIG Catalog Number	Neutral CT for LSG and LSIG <sup>①</sup> Catalog Number
<b>Three-Pole</b>					
50	JGC305033G	JGC305032G	JGC305035G	JGC305036G	JGFCT050
100	JGC310033G	JGC310032G	JGC310035G	JGC310036G	JGFCT100
160	JGC316033G	JGC316032G	JGC316035G	JGC316036G	JGFCT160
250	JGC335033G	JGC325032G	JGC325035G	JGC325036G	JGFCT250
<b>Four-Pole <sup>②</sup></b>					
50	JGC405033G	JGC405032G	JGC405035G	JGC405036G	—
100	JGC410033G	JGC410032G	JGC410035G	JGC410036G	—
160	JGC416033G	JGC416032G	JGC416035G	JGC416036G	—
250	JGC435033G	JGC425032G	JGC425035G	JGC425036G	—

## IEC/UL/CSA—150/150, Current Limiting Per UL 489

Ampere Rating	LS Catalog Number	LSI Catalog Number	LSG Catalog Number	LSIG Catalog Number	Neutral CT for LSG and LSIG <sup>①</sup> Catalog Number
<b>Three-Pole</b>					
50	JGU305033G	JGU305032G	JGU305035G	JGU305036G	JGFCT050
100	JGU310033G	JGU310032G	JGU310035G	JGU310036G	JGFCT100
160	JGU316033G	JGU316032G	JGU316035G	JGU316036G	JGFCT160
250	JGU335033G	JGU325032G	JGU325035G	JGU325036G	JGFCT250
<b>Four-Pole <sup>②③</sup></b>					
50	JGU405033G	JGU405032G	JGU405035G	JGU405036G	—
100	JGU410033G	JGU410032G	JGU410035G	JGU410036G	—
160	JGU416033G	JGU416032G	JGU416035G	JGU416036G	—
250	JGU435033G	JGU425032G	JGU425035G	JGU425036G	—

## IEC/UL/CSA—200/200, Current Limiting Per UL 489

Ampere Rating	LS Catalog Number	LSI Catalog Number	LSG Catalog Number	LSIG Catalog Number	Neutral CT for LSG and LSIG <sup>①</sup> Catalog Number
<b>Three-Pole</b>					
50	JGX305033G	JGX305032G	JGX305035G	JGX305036G	JGFCT050
100	JGX310033G	JGX310032G	JGX310035G	JGX310036G	JGFCT100
160	JGX316033G	JGX316032G	JGX316035G	JGX316036G	JGFCT160
250	JGX325033G	JGX325032G	JGX325035G	JGX325036G	JGFCT250
<b>Four-Pole <sup>②</sup></b>					
50	JGX405033G	JGX405032G	JGX405035G	JGX405036G	—
100	JGX410033G	JGX410032G	JGX410035G	JGX410036G	—
160	JGX416033G	JGX416032G	JGX416035G	JGX416036G	—
250	JGX425033G	JGX425032G	JGX425035G	JGX425036G	—

**Notes**

- <sup>①</sup> Required for four-wire systems if neutral protection is required.  
<sup>②</sup> Neutral protection 4 = 0%, 7 = 100% electronic trip unit neutral protection is not adjustable.  
<sup>③</sup> Four-pole breakers with LSG and LSIG trip units are only available with 0% neutral protection.

**JG 100% Rated Circuit Breaker—Thermal-Magnetic Trip Unit****Complete Breaker (Includes Frame, Trip Unit, Standard Terminals and Mounting Hardware)—IC Rating at 415/480 Volts****JG-Frame****JG-Frame—IEC/CE/UL/CSA—25/25**

Maximum Continuous Amperes	Magnetic Range	Three-Pole
		Fixed Thermal, Adjustable Magnetic Catalog Number
70	350–700	<b>JGE3070FAGC</b>
90	450–900	<b>JGE3090FAGC</b>
100	500–1000	<b>JGE3100FAGC</b>
125	625–1250	<b>JGE3125FAGC</b>
150	750–1550	<b>JGE3150FAGC</b>
160	800–1600	—
175	875–1750	<b>JGE3175FAGC</b>
200	1000–2000	<b>JGE3200FAGC</b>
225	1125–2250	<b>JGE3225FAGC</b>
250	1250–2500	<b>JGE3250FAGC</b>

**JG-Frame—IEC/CE/UL/CSA—70/65**

Maximum Continuous Amperes	Magnetic Range	Three-Pole
		Fixed Thermal, Adjustable Magnetic Catalog Number
70	350–700	<b>JGH3070FAGC</b>
90	450–900	<b>JGH3090FAGC</b>
100	500–1000	<b>JGH3100FAGC</b>
125	625–1250	<b>JGH3125FAGC</b>
150	750–1550	<b>JGH3150FAGC</b>
160	800–1600	—
175	875–1750	<b>JGH3175FAGC</b>
200	1000–2000	<b>JGH3200FAGC</b>
225	1125–2250	<b>JGH3225FAGC</b>
250	1250–2500	<b>JGH3250FAGC</b>

**JG-Frame—IEC/CE/UL/CSA—40/35**

Maximum Continuous Amperes	Magnetic Range	Three-Pole
		Fixed Thermal, Adjustable Magnetic Catalog Number
70	350–700	<b>JGS3070FAGC</b>
90	450–900	<b>JGS3090FAGC</b>
100	500–1000	<b>JGS3100FAGC</b>
125	625–1250	<b>JGS3125FAGC</b>
150	750–1550	<b>JGS3150FAGC</b>
160	800–1600	—
175	875–1750	<b>JGS3175FAGC</b>
200	1000–2000	<b>JGS3200FAGC</b>
225	1125–2250	<b>JGS3225FAGC</b>
250	1250–2500	<b>JGS3250FAGC</b>

# 2.2

## Molded Case Circuit Breakers

### Series G

#### JG 100% Rated 310+ Electronic Trip Unit Circuit Breaker

See 310+ adjustability specifications on **Page V4-T2-44**.

2

#### IEC/UL/CSA—25/25

Ampere Rating	LS Catalog Number	LSI Catalog Number	LSG Catalog Number	LSIG Catalog Number	Neutral CT for LSG and LSIG <sup>①</sup> Catalog Number
50	JGE305033GC	JGE305032GC	JGE305035GC	JGE305036GC	JGFCT050
100	JGE310033GC	JGE310032GC	JGE310035GC	JGE310036GC	JGFCT100
160	JGE316033GC	JGE316032GC	JGE316035GC	JGE316036GC	JGFCT160
250	JGE325033GC	JGE325032GC	JGE325035GC	JGE325036GC	JGFCT250

#### IEC/UL/CSA—40/35

Ampere Rating	LS Catalog Number	LSI Catalog Number	LSG Catalog Number	LSIG Catalog Number	Neutral CT for LSG and LSIG <sup>①</sup> Catalog Number
50	JGS305033GC	JGS305032GC	JGS305035GC	JGS305036GC	JGFCT050
100	JGS310033GC	JGS310032GC	JGS310035GC	JGS310036GC	JGFCT100
160	JGS316033GC	JGS316032GC	JGS316035GC	JGS316036GC	JGFCT160
250	JGS325033GC	JGS325032GC	JGS325035GC	JGS325036GC	JGFCT250

#### IEC/UL/CSA—70/65

Ampere Rating	LS Catalog Number	LSI Catalog Number	LSG Catalog Number	LSIG Catalog Number	Neutral CT for LSG and LSIG <sup>①</sup> Catalog Number
50	JGH305033GC	JGH305032GC	JGH305035GC	JGH305036GC	JGFCT050
100	JGH310033GC	JGH310032GC	JGH310035GC	JGH310036GC	JGFCT100
160	JGH316033GC	JGH316032GC	JGH316035GC	JGH316036GC	JGFCT160
250	JGH325033GC	JGH325032GC	JGH325035GC	JGH325036GC	JGFCT250

#### Note

<sup>①</sup> Required for four-wire systems if neutral protection is required.

Accessories Selection Guide and Ordering Information

JG-Frame

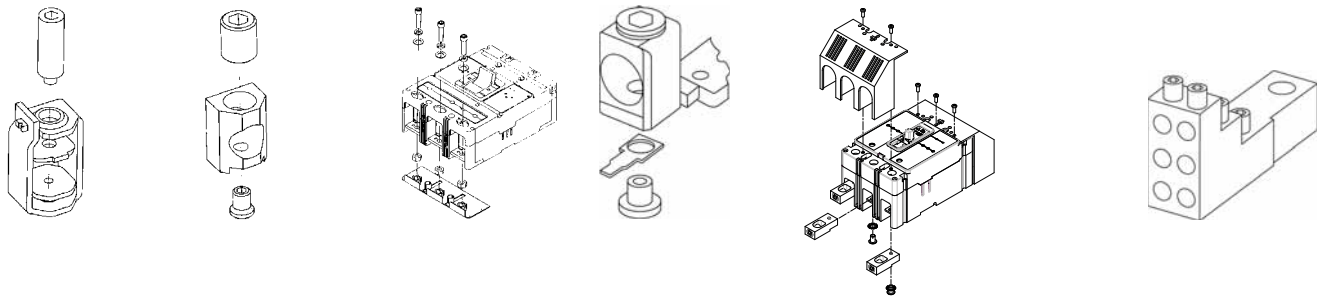

T250FJ	TA250FJ	Endcap Kit	Control Wire Terminal Kit	Rear Fed Terminals	Multiwire Connectors
--------	---------	------------	---------------------------	--------------------	----------------------

Load and Line Terminals

Maximum Breaker Amperes	Terminal Body Material	Wire Type	Metric Wire Range mm <sup>2</sup>	AWG Wire Range/ Number of Conductors	Catalog Number
<b>Standard Pressure Type Terminals</b>					
250	Stainless steel	Cu	25–185	#4–350 (1)	T250FJ ①
250	Aluminum	Cu/Al	10–185	#8–350 (1)	TA250FJ ①②

JG-Frame circuit breakers include aluminum terminals TA250FJ as standard. When optional stainless steel only terminals are required, order by catalog number.

Endcap Kits

Number of Poles	Catalog Number	
	Metric	Imperial
3	FJ3RTWK	FJ3RTDK
4	FJ4RTWK	FJ4RTDK

Endcap kits are used on J250-Frame breaker to connect busbar or similar electrical connections. Includes hardware.

Control Wire Terminal Kit

Description	Catalog Number
Package of 14 (priced individually)	FJCWTK

For use with aluminum or copper terminals only.

Rear Fed Terminals

Maximum Amperes	Wire Size Range AWG Cu	Catalog Number
250	#4–350 kcmil	TA250JGRF
		3TA250JGRF

Rear fed terminals allow the cable to connect to the breaker from the back instead of the top. Terminal shields or interphase barriers are included with each rear fed terminal kit (depending on frame size). When catalog number starts with a 3, it indicates a kit with three terminals in each kit. Catalog number beginning with a TA indicates one terminal.

Base Mounting Hardware

Base mounting hardware is included with a circuit breaker or molded case switch. (Included with breaker.) If required separately, order 66A2546G02.

Terminal Shields IP30

Location	Number of Poles	Catalog Number
Line or Load	2, 3	FJTS3K
	4	FJTS4K

Interphase Barriers

Number of Poles	Catalog Number
3	FJIPBK ③
4	FJIPBK4 ③

Multiwire Connectors

Field-installed multiwire connectors for the load side (OFF) end terminals are used to distribute the load from the circuit breaker to multiple devices without the use of separate distribution terminal blocks.

Multiwire lug kits include terminal shield, mounting hardware, insulators and tin-plated aluminum connectors to replace three mechanical load lugs. UL listed as used on the load side (OFF) end.

JG-Frame Multiwire Connectors Ordering Information (Package of 3)

Maximum Amperes	Wires per Terminal	Wire Size Range AWG Cu	Kit Catalog Number
250	3	14–2	3TA250FJ3
250	6	14–6	3TA250FJ6

Notes

- ① Individually packed.
- ② Standard line and load.
- ③ Individually priced.

## Accessories

2

### Allowable Accessory Combinations

Different combinations of accessories can be supplied, depending on the types of accessories and the number of poles in the circuit breaker.

### JG-Frame Accessories

Description	Reference Page	Two- and Three-Pole			Four-Pole			
		Left	Center	Right	Left	Center	Right	Neutral
<b>Internal Accessories (Only one internal accessory per pole)</b>								
Alarm lockout (Make/Break)	V4-T2-109	—	—	■	—	—	■	—
Auxiliary switch (1A, 1B)	V4-T2-109	—	—	■	—	—	■	—
Auxiliary switch (2A, 2B)	V4-T2-109	—	—	■	—	—	■	—
Auxiliary switch and alarm switch combination	V4-T2-109	—	—	■	—	—	■	—
Shunt trip—standard	V4-T2-109	■	—	—	■	—	—	—
Undervoltage release mechanism	V4-T2-110	■	—	—	■	—	—	—
<b>External Accessories</b>								
End cap kit	V4-T2-41	●	●	●	●	●	●	●
Control wire terminal kit	V4-T2-41	●	●	●	●	●	●	●
Rear fed terminals	V4-T2-41	●	●	●	●	●	●	●
Multiwire connectors	V4-T2-41	●	●	●	●	●	●	●
Base mounting hardware	V4-T2-41	●	●	●	●	●	●	●
Interphase barriers	V4-T2-41	●	●	●	●	●	●	●
Padlockable handle block	V4-T2-107	—	■	—	—	■	—	—
Padlockable handle lock hasp	V4-T2-107	□	—	□	□	—	□	—
Key interlock kit	V4-T2-107	□	—	□	□	—	□	—
Sliding bar interlock—requires two breakers	V4-T2-107	●	●	●	—	—	—	—
Electrical operator	V4-T2-107	●	●	●	●	●	●	●
Plug-in adapters	V4-T2-107	●	●	●	●	●	●	●
Handle mechanisms	V4-T2-420	●	●	●	●	●	●	●
Earth leakage/ground fault protector	V4-T2-92	●	●	●	●	●	●	●
Drawout cassette	V4-T2-115	●	●	●	●	●	●	●
Digitrip 310+ test kit	V4-T2-36	●	●	●	●	●	●	●
Ammeter/cause of trip display	V4-T2-106	●	●	●	●	●	●	●
Cause of trip LED module	V4-T2-106	●	●	●	●	●	●	●
<b>Modifications (Refer to Eaton)</b>								
Moisture fungus treatment	V4-T2-105	●	●	●	●	●	●	●
Freeze-tested circuit breakers	—	●	●	●	●	●	●	●
Marine/naval application, UL 489 supplement SA and SB	①	●	●	●	●	●	●	●

#### Legend

- Applicable in indicated pole position
- May be mounted on left or right pole—not both
- Accessory available/modification available

#### Note

① Contact Eaton.

## Technical Data and Specifications

### UL 489/IEC 60947-2 Interrupting Capacity (Symmetrical Amperes) (kA) Ratings

Circuit Breaker Type	Number of Poles	Volts AC (50/60 Hz)								Volts DC <sup>①</sup>
		220–240		380–415		480	600	690 <sup>②</sup>		250 <sup>②③</sup>
		I <sub>cu</sub>	I <sub>cs</sub>	I <sub>cu</sub>	I <sub>cs</sub>			I <sub>cu</sub>	I <sub>cs</sub>	
JGE250	2, 3, 4	65	65	25	25	25	18	12	6	10
JGS250	2, 3, 4	85	85	40	40	35	18	12	6	22
JGH250	2, 3, 4	100	100	70	70	65	25	14	7	22
JGC250 <sup>④</sup>	3, 4	200	200	100	100	100	35	16	12	42
JGU250 <sup>④</sup>	3, 4	200	200	150	150	150	50	18	14	50
JGX250 <sup>④</sup>	3, 4	200	200	200	200	200	50	18	14	50

### UL 489 Current Limiting Data

Frame	Circuit	I <sub>p</sub> (kA)	I <sup>2</sup> T (10 <sup>6</sup> A <sup>2</sup> S)
JGC	240 V/200 kA	45.1	1.820
JGC	480 V/100 kA	45.1	1.820
JGC	600 V/35 kA	32.8	2.140
JGU	240 V/200 kA	45.1	1.820
JGU	480 V/150 kA	45.1	1.820
JGU	600 V/50 kA	32.8	2.140
JGX	240 V/200 kA	45.1	1.820
JGX	480 V/200 kA	45.1	1.820
JGX	600 V/50 kA	32.8	2.140

### JG 310+ Specifications

Description	Specification
Trip Unit Type	Digitrip RMS 310+
<b>Breaker Type</b>	
Frame designation	JG
Frames available	50 A, 100 A, 160 A 250 A
Continuous current range (A)	20–250A
Ground fault pickup (A)	10–250A
Interrupting capacities at 480 Vac (kAIC)	35, 65, 100, 150, 200
100% rated	Yes
<b>Protection</b>	
Ordering options	LS, LSI, LSG, LSIG
Arcflash reduction maintenance system (or maintenance mode)	No
Interchangeable trip unit	Yes
High load alarm (suffix B20) <sup>⑤</sup>	Yes
Ground fault alarm with trip (suffix B21) <sup>⑤</sup>	Yes
Ground fault alarm, no trip (suffix B22) <sup>⑤</sup>	Yes
Zone selective interlocking (suffix ZG)	LSI, LSIG
Cause of trip indication	Yes
Thru-cover accessories	Yes

#### Notes

- ① DC ratings apply to substantially non-inductive circuits.
- ② Two-pole circuit breaker, or two poles of three-pole circuit breaker.
- ③ Time constant is 3 milliseconds minimum at 10 kA and 8 milliseconds minimum at 22 kA.
- ④ Current limiting per UL 489.
- ⑤ B2x suffixes cannot be combined with B2x suffixes.

## JG 310+ Adjustability Specifications

2

310+ Settings		JG Frame			
		50 A	100 A	160 A	250 A
$I_r$ = continuous current or long delay pickup (amperes) (All 310+)	$I_r$				
	A	20	40	63	100
	B	20	45	80	125
	C	25	50	90	150
	D	30	63	100	160
	E	32	70	110	175
	F	40	80	125	200
	G	45	90	150	225
	H (= $I_n$ )	50	100	160	250
$t_r$ = long delay time (seconds) (All 310+)	Position 1	2	2	2	2
	Position 2	4	4	4	4
	Position 3	7	7	7	7
	Position 4	10	10	10	10
	Position 5	12	12	12	12
	Position 6	15	15	15	15
	Position 7	20	20	20	20
	Position 8	24	24	24	24
$I_{sd}$ (x $I_r$ ) = short delay pickup (All 310+)	Position 1	2x	2x	2x	2x
	Position 2	3x	3x	3x	3x
	Position 3	4x	4x	4x	4x
	Position 4	5x	5x	5x	5x
	Position 5	6x	6x	6x	6x
	Position 6	7x	7x	7x	7x
	Position 7	8x	8x	8x	8x
	Position 8	10x	10x	10x	10x
	Position 9	14x	14x	14x	14x
$t_{sd}$ = short delay time $I^2t$ (milliseconds) (LS, LSG)	Fixed	67 at10x	67 at10x	67 at10x	67 at10x
$t_{sd}$ = short delay time flat (milliseconds) (LSI, LSIG)	Position 1	Inst	Inst	Inst	Inst
	Position 2	120	120	120	120
	Position 3	300	300	300	300
$I_g$ = ground fault pickup (amperes) (LSG, LSIG)	Position 1	10	20	32	50
	Position 2	15	30	48	75
	Position 3	20	40	64	100
	Position 4	30	60	96	150
	Position 5	40	80	128	200
	Position 6	50	100	160	250
$t_g$ = ground fault delay time (milliseconds) (LSG, LSIG)	Position 1	Inst	Inst	Inst	Inst
	Position 2	120	120	120	120
	Position 3	300	300	300	300
Independently Adjustable Instantaneous ( $I_i$ ) setting <sup>①</sup>		N/A			
Maintenance Mode pickup (2.5 x $I_n$ ) (amperes) <sup>②</sup>		N/A			

**Notes**

① Not available for JG. Independently adjustable  $I_i$  setting available in LG, NG and RG ALSI and ALSIG trip units.

② Maintenance Mode not available for JG frames. It is available for KD, LD, MDL, LG, NG, and RG.

**Dimensions and Weights**

Approximate Dimensions in Inches (mm)

**JG-Frame**

Number of Poles	Width	Height	Depth
2, 3	4.13 (104.9)	7.00 (177.8)	3.57 (90.7)
4	5.34 (135.6)	7.00 (177.8)	3.57 (90.7)

**JG-Frame**

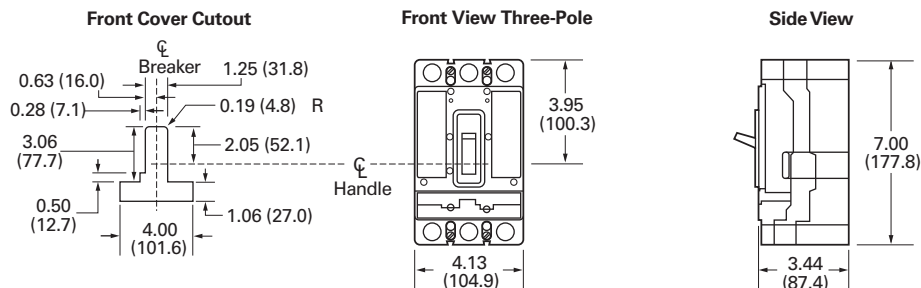

Approximate Shipping Weight in Lbs (kg)

**JG-Frame**

Breaker Type	Number of Poles	
	2, 3	4
JGC	6.00 (2.70)	8.00 (3.60)
JGE	6.00 (2.70)	8.00 (3.60)
JGH	6.00 (2.70)	8.00 (3.60)
JGS	6.00 (2.70)	8.00 (3.60)
JGU	6.00 (2.70)	8.00 (3.60)
JGX	6.00 (2.70)	8.00 (3.60)

# 2.2

## Molded Case Circuit Breakers

### Series G

#### JG-Frame With Earth Leakage Module

2

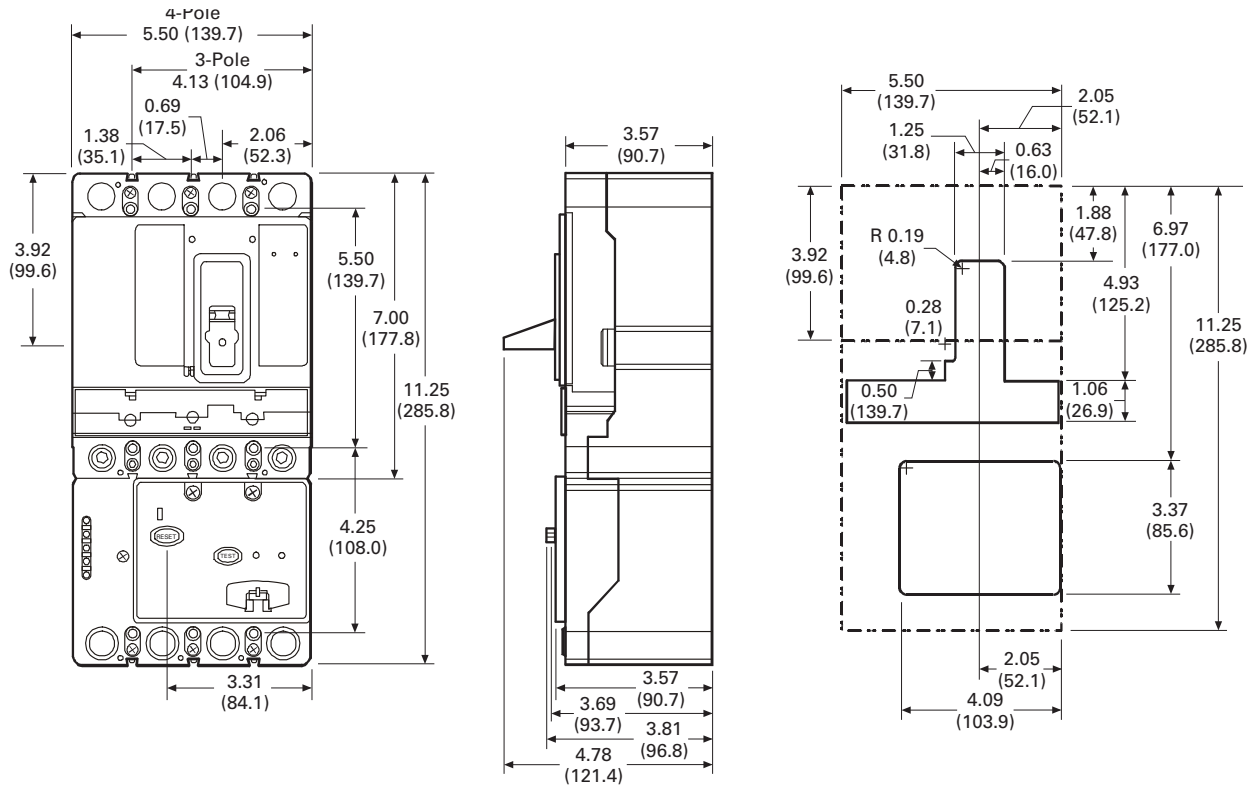

**LG-Frame (250–630 Amperes)****LG-Frame (250–630 Amperes)****Product Description**

LG breaker is HACR rated.

**Contents****Description****Page**

EG-Frame (15–125 Amperes) . . . . .	<b>V4-T2-15</b>
JG-Frame (63–250 Amperes) . . . . .	<b>V4-T2-29</b>
LG-Frame (250–630 Amperes)	
Catalog Number Selection . . . . .	<b>V4-T2-48</b>
Product Selection . . . . .	<b>V4-T2-49</b>
Accessories . . . . .	<b>V4-T2-60</b>
Technical Data and Specifications . . . . .	<b>V4-T2-61</b>
Dimensions and Weights. . . . .	<b>V4-T2-63</b>
NG-Frame (320–1200 Amperes) . . . . .	<b>V4-T2-65</b>
RG-Frame (800–2500 Amperes) . . . . .	<b>V4-T2-74</b>
Motor Circuit Protectors (MCP) . . . . .	<b>V4-T2-85</b>
Motor Protector Circuit Breakers (MPCB). . . . .	<b>V4-T2-89</b>
30 mA Ground Fault (Earth Leakage) Module . . . . .	<b>V4-T2-92</b>
Current Limiting Circuit Breaker Module . . . . .	<b>V4-T2-96</b>
High Instantaneous Circuit Breaker for	
Selective Coordination . . . . .	<b>V4-T2-101</b>
Special Features and Accessories. . . . .	<b>V4-T2-104</b>
Motor Operators . . . . .	<b>V4-T2-112</b>
Plug-In Blocks . . . . .	<b>V4-T2-114</b>
Drawout Cassette . . . . .	<b>V4-T2-115</b>

# 2.2

## Molded Case Circuit Breakers

### Series G

#### Catalog Number Selection

This information is presented only as an aid to understanding catalog numbers. It is not to be used to build catalog numbers for circuit breakers or trip units.

2

#### Series G—LG-Frame (250–630 Amperes)

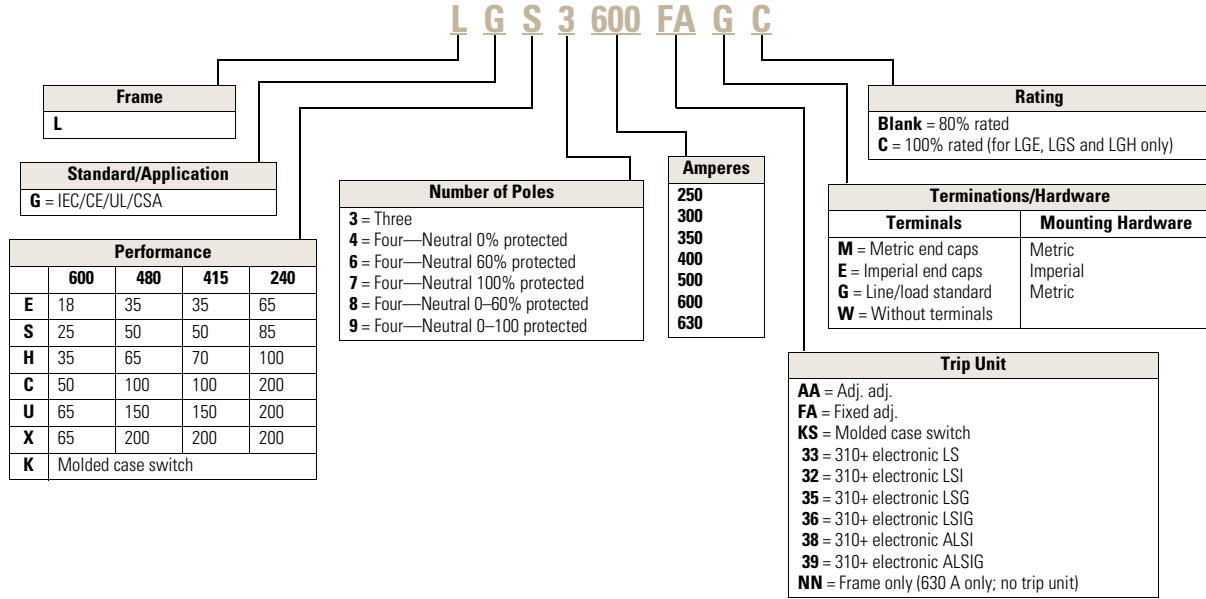

#### Trip Unit

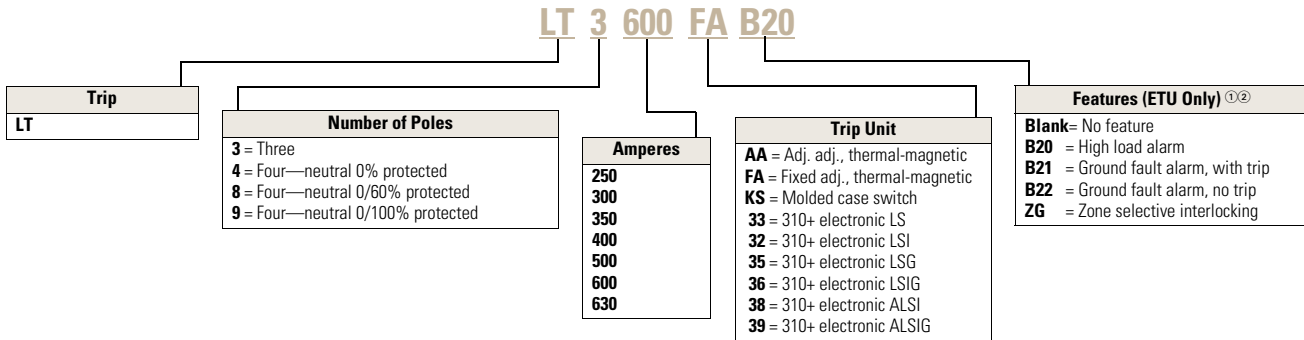

#### Notes

- ① Bxx features cannot be combined with other Bxx features.
- ② B21 and B22 available with LSG and LSIG trip units.

## Product Selection

Complete Breaker (Includes Frame, Trip Unit, Standard Terminals and Mounting Hardware)

## LG-Frame

**LG-Frame—630 Amperes (600 Amperes UL, CSA)**  
 IC Rating: 35 kAIC at 415 and 480 Vac <sup>①</sup>

Ampere Rating	Three-Pole <sup>②</sup>		Four-Pole (0%) <sup>③</sup>	
	Fixed Thermal, Adjustable Magnetic Catalog Number	Adjustable Thermal, Adjustable Magnetic <sup>④⑤</sup> Catalog Number	Fixed Thermal, Adjustable Magnetic Catalog Number	Adjustable Thermal, Adjustable Magnetic <sup>④⑤</sup> Catalog Number
250	LGE3250FAG	LGE3250AAG	LGE4250FAG	LGE4250AAG
300	LGE3300FAG	—	LGE4300FAG	—
320	—	LGE3320AAG	—	LGE4320AAG
350	LGE3350FAG	—	LGE4350FAG	—
400	LGE3400FAG	LGE3400AAG	LGE4400FAG	LGE4400AAG
500	LGE3500FAG	LGE3500AAG	LGE4500FAG	LGE4500AAG
600	LGE3600FAG	—	LGE4600FAG	—
630 <sup>④</sup>	—	LGE3630AAG	—	LGE4630AAG

## LG-Frame

**LG-Frame—630 Amperes (600 Amperes UL, CSA)**  
 IC Rating: 50 kAIC at 415 and 480 Vac <sup>①</sup>

Ampere Rating	Three-Pole <sup>②</sup>		Four-Pole (0%) <sup>③</sup>	
	Fixed Thermal, Adjustable Magnetic Catalog Number	Adjustable Thermal, Adjustable Magnetic <sup>④⑤</sup> Catalog Number	Fixed Thermal, Adjustable Magnetic Catalog Number	Adjustable Thermal, Adjustable Magnetic <sup>④⑤</sup> Catalog Number
250	LGS3250FAG	LGS3250AAG	LGS4250FAG	LGS4250AAG
300	LGS3300FAG	—	LGS4300FAG	—
320	—	LGS3320AAG	—	LGS4320AAG
350	LGS3350FAG	—	LGS4350FAG	—
400	LGS3400FAG	LGS3400AAG	LGS4400FAG	LGS4400AAG
500	LGS3500FAG	LGS3500AAG	LGS4500FAG	LGS4500AAG
600	LGS3600FAG	—	LGS4600FAG	—
630 <sup>④</sup>	—	LGS3630AAG	—	LGS4630AAG

## LG-Frame

**LG-Frame—630 Amperes (600 Amperes UL, CSA)**  
 IC Rating: 70 kAIC at 415, 65 kAIC at 480 Vac <sup>①</sup>

Ampere Rating	Three-Pole <sup>②</sup>		Four-Pole (0%) <sup>③</sup>	
	Fixed Thermal, Adjustable Magnetic Catalog Number	Adjustable Thermal, Adjustable Magnetic <sup>④⑤</sup> Catalog Number	Fixed Thermal, Adjustable Magnetic Catalog Number	Adjustable Thermal, Adjustable Magnetic <sup>④⑤</sup> Catalog Number
250	LGH3250FAG	LGH3250AAG	LGH4250FAG	LGH4250AAG
300	LGH3300FAG	—	LGH4300FAG	—
320	—	LGH3320AAG	—	LGH4320AAG
350	LGH3350FAG	—	LGH4350FAG	—
400	LGH3400FAG	LGH3400AAG	LGH4400FAG	LGH4400AAG
500	LGH3500FAG	LGH3500AAG	LGH4500FAG	LGH4500AAG
600	LGH3600FAG	—	LGH4600FAG	—
630 <sup>④</sup>	—	LGH3630AAG	—	LGH4630AAG

## Notes

- ① Replace suffix "G" with "W" for no line and load terminals.
- ② For two-pole applications, use two outer poles.
- ③ Neutral protection is indicated by the fourth character: 4 = 0%, 7 = 100%, 8 = adjustable 0–60% and 9 = 0–100%. Neutral is on LH side.
- ④ 320/630 amperes is not a UL or CSA listed rating. 600 amperes is the maximum UL and CSA rating for the LG.
- ⑤ Adjustable thermal units are typically used in IEC markets and are not UL or CSA listed.

#### Complete Breaker (Includes Frame, Trip Unit, Standard Terminals and Mounting Hardware)

2

##### LG-Frame



#### LG-Frame—630 Amperes (600 Amperes UL, CSA), Current Limiting Per UL 489 IC Rating: 100 kAIC at 415 and 480 Vac <sup>①</sup>

Ampere Rating	Three-Pole <sup>②</sup> Fixed Thermal, Adjustable Magnetic		Four-Pole (0%) <sup>③</sup> Fixed Thermal, Adjustable Magnetic	
	Catalog Number	Adjustable Thermal, Adjustable Magnetic <sup>④⑤</sup> Catalog Number	Catalog Number	Adjustable Thermal, Adjustable Magnetic <sup>④⑤</sup> Catalog Number
250	LGC3250FAG	LGC3250AAG	LGC4250FAG	LGC4250AAG
300	LGC3300FAG	—	LGC4300FAG	—
320	—	LGC3320AAG	—	LGC4320AAG
350	LGC3350FAG	—	LGC4350FAG	—
400	LGC3400FAG	LGC3400AAG	LGC4400FAG	LGC4400AAG
500	LGC3500FAG	LGC3500AAG	LGC4500FAG	LGC4500AAG
600	LGC3600FAG	—	LGC4600FAG	—
630 <sup>④</sup>	—	LGC3630AAG	—	LGC4630AAG

##### LG-Frame



#### LG-Frame—630 Amperes (600 Amperes UL, CSA), Current Limiting Per UL 489 IC Rating: 150 kAIC at 415 and 480 Vac <sup>①</sup>

Ampere Rating	Three-Pole <sup>②</sup> Fixed Thermal, Adjustable Magnetic		Four-Pole (0%) <sup>③</sup> Fixed Thermal, Adjustable Magnetic	
	Catalog Number	Adjustable Thermal, Adjustable Magnetic <sup>④⑤</sup> Catalog Number	Catalog Number	Adjustable Thermal, Adjustable Magnetic <sup>④⑤</sup> Catalog Number
250	LGU3250FAG	LGU3250AAG	LGU4250FAG	LGU4250AAG
300	LGU3300FAG	—	LGU4300FAG	—
320	—	LGU3320AAG	—	LGU4320AAG
350	LGU3350FAG	—	LGU4350FAG	—
400	LGU3400FAG	LGU3400AAG	LGU4400FAG	LGU4400AAG
500	LGU3500FAG	LGU3500AAG	LGU4500FAG	LGU4500AAG
600	LGU3600FAG	—	LGU4600FAG	—
630 <sup>④</sup>	—	LGU3630AAG	—	LGU4630AAG

##### LG-Frame



#### LG-Frame—630 Amperes (600 Amperes UL, CSA), Current Limiting Per UL 489 IC Rating: 200 kAIC at 415 and 480 Vac <sup>①</sup>

Ampere Rating	Three-Pole <sup>②</sup> Fixed Thermal, Adjustable Magnetic		Four-Pole (0%) <sup>③</sup> Fixed Thermal, Adjustable Magnetic	
	Catalog Number	Adjustable Thermal, Adjustable Magnetic <sup>④⑤</sup> Catalog Number	Catalog Number	Adjustable Thermal, Adjustable Magnetic <sup>④⑤</sup> Catalog Number
250	LGX3250FAG	LGX3250AAG	LGX4250FAG	LGX4250AAG
300	LGX3300FAG	—	LGX4300FAG	—
320	—	LGX3320AAG	—	LGX4320AAG
350	LGX3350FAG	—	LGX4350FAG	—
400	LGX3400FAG	LGX3400AAG	LGX4400FAG	LGX4400AAG
500	LGX3500FAG	LGX3500AAG	LGX4500FAG	LGX4500AAG
600	LGX3600FAG	—	LGX4600FAG	—
630 <sup>④</sup>	—	LGX3630AAG	—	LGX4630AAG

#### Notes

- ① Replace suffix "G" with "W" for no line and load terminals.
- ② For two-pole applications, use two outer poles.
- ③ Neutral protection is indicated by the fourth character: 4 = 0%, 7 = 100%, 8 = adjustable 0–60% and 9 = 0–100%. Neutral is on LH side.
- ④ 320/630 amperes is not a UL or CSA listed rating. 600 amperes is the maximum UL and CSA rating for the LG.
- ⑤ Adjustable thermal units are typically used in IEC markets and are not UL or CSA listed.

**Molded Case Switches** <sup>①</sup>

Ampere Rating	Number of Poles	Catalog Number
400	3 <sup>②</sup>	LGK3400KSG
	4	LGK4400KSG
630 <sup>③</sup>	3 <sup>②</sup>	LGK3630KSG
	4	LGK4630KSG

**Frame—IC Rating at 415/480 Volts**

Maximum Amperes <sup>③</sup>	Three-Pole <sup>②</sup> Catalog Number	Four-Pole 0% Catalog Number
<b>35/35</b>		
630 <sup>③</sup>	LGE3630NN	LGE4630NN
	LGE3630NNWC	—
<b>50/50</b>		
630 <sup>③</sup>	LGS3630NN	LGS4630NN
	LGS3630NNWC	—
<b>70/53</b>		
630 <sup>③</sup>	LGH3630NN	LGH4630NN
	LGH3630NNWC	—
<b>100/100 Current Limiting Per UL 489</b>		
630	LGC3630NN	LGC4630NN
<b>150/150 Current Limiting Per UL 489</b>		
630	LGU3630NN	LGU4630NN
<b>200/200 Current Limiting</b>		
630	LGX3630NN	LGX4630NN

**Thermal-Magnetic Trip Unit**

Ampere Rating	Three-Pole <sup>②</sup> Fixed Thermal, Adjustable Magnetic Catalog Number	Adjustable Thermal, Adjustable Magnetic <sup>④</sup> Catalog Number	Four-Pole (0%) <sup>⑤</sup> Fixed Thermal, Adjustable Magnetic Catalog Number	Adjustable Thermal, Adjustable Magnetic <sup>④</sup> Catalog Number
	250	LT3250FA	LT3250AA	LT4250FA
300	LT3300FA	—	LT4300FA	—
320	—	LT3320AA	—	LT4320AA
350	LT3350FA	—	LT4350FA	—
400	LT3400FA	LT3400AA	LT4400FA	LT4400AA
500	LT3500FA	LT3500AA	LT4500FA	LT4500AA
600	LT3600FA	—	LT4600FA	—
630	—	LT3630AA	—	LT4630AA

**Notes**

① Molded case switches will trip above 6300 amperes.

② For two-pole applications, use two outer poles.

③ 630 amperes is not a UL or CSA listed rating. 600 amperes is the maximum UL and CSA rating for the LG.

④ Adjustable thermal, adjustable magnetic trip units are typically used in IEC markets and are not UL or CSA listed.

⑤ Neutral protection is indicated by the third character: 4 = 0%, 7 = 100%, 8 = adjustable 0–60% and 9 = 0–100%.

⑥ 100% rated frame.

**Digitrip 310+ Electronic Trip Units**See 310+ adjustability specifications on **Page V4-T2-62**.

2

Ampere Rating	LS Catalog Number	LSI Catalog Number	LSG Catalog Number	LSIG Catalog Number	Neutral CT for LSG and LSIG <sup>①</sup> Catalog Number
<b>Three-Pole</b>					
250	LT325033	LT325032	LT325035	LT325036	LGFACT250
400	LT340033	LT340032	LT340035	LT340036	LGFACT400
600	LT360033	LT360032	LT360035	LT360036	LGFACT600
630 <sup>②</sup>	LT363033	LT363032	LT363035	LT363036	LGFACT600
<b>Four-Pole <sup>③④</sup></b>					
250	LT425033	LT425032	LT425035	LT425036	—
400	LT440033	LT440032	LT440035	LT440036	—
600	LT460033	LT460032	LT460035	LT460036	—
630 <sup>②</sup>	LT463033	LT463032	LT463035	LT463036	—

**310+ Electronic Trip Unit Accessories**

Description	Catalog Number
Electronic portable test kit	MTST230V
Trip unit tamper protection wire seal	5108A03H01
External neutral sensor (630 A)	LGFACT630
External neutral sensor (600 A)	LGFACT600
External neutral sensor (400 A)	LGFACT400
External neutral sensor (250 A)	LGFACT250
Breaker-mount cause-of-trip indication	TRIP-LED
Breaker-mount ammeter module	DIGIVIEW
Remote-mount ammeter module	DIGIVIEWR06

**Notes**

- ① Required for four-wire systems if neutral protection is desired.
- ② 630 amperes is not a UL or CSA listed rating. 600 amperes is the maximum UL and CSA listed rating for the LG.
- ③ Neutral protection: 4= 0%, 6 = 60%, 7 = 100%. Electronic trip unit neutral protection is not adjustable.
- ④ Four-pole LSG and LSIG trip units are only available with 0% neutral protection.

**IC Rating at 415/480 V****Complete LG Breakers with Electronic Trip Unit (Includes Frame, Trip Unit, Standard Terminals and Mounting Hardware) ①**See 310+ adjustability specifications on **Page V4-T2-62**.**IC Rating: 35 kAIC at 415 and 480 Vac**

Ampere Rating	LS Catalog Number	LSI Catalog Number	LSG Catalog Number	LSIG Catalog Number	Neutral CT for LSG and LSIG ② Catalog Number
<b>Three-Pole ③</b>					
250	LGE325033G	LGE325032G	LGE325035G	LGE325036G	LGFACT250
400	LGE340033G	LGE340032G	LGE340035G	LGE340036G	LGFACT400
600	LGE360033G	LGE360032G	LGE360035G	LGE360036G	LGFACT600
630 ④	LGE363033G	LGE363032G	LGE363035G	LGE363036G	LGFACT600
<b>Four-Pole ⑤</b>					
250	LGE425033G	LGE425032G	LGE425035G	LGE425036G	—
400	LGE440033G	LGE440032G	LGE440035G	LGE440036G	—
600	LGE460033G	LGE460032G	LGE460035G	LGE460036G	—
630 ④	LGE463033G	LGE463032G	LGE463035G	LGE463036G	—

**IC Rating: 50 kAIC at 415 and 480 Vac**

Ampere Rating	LS Catalog Number	LSI Catalog Number	LSG Catalog Number	LSIG Catalog Number	Neutral CT for LSG and LSIG ② Catalog Number
<b>Three-Pole ③</b>					
250	LGS325033G	LGS325032G	LGS325035G	LGS325036G	LGFACT250
400	LGS340033G	LGS340032G	LGS340035G	LGS340036G	LGFACT400
600	LGS360033G	LGS360032G	LGS360035G	LGS360036G	LGFACT600
630 ④	LGS363033G	LGS363032G	LGS363035G	LGS363036G	LGFACT600
<b>Four-Pole ⑤⑥</b>					
250	LGS425033G	LGS425032G	LGS425035G	LGS425036G	—
400	LGS440033G	LGS440032G	LGS440035G	LGS440036G	—
600	LGS460033G	LGS460032G	LGS460035G	LGS460036G	—
630 ④	LGS463033G	LGS463032G	LGS463035G	LGS463036G	—

**IC Rating: 70 kAIC at 415 Vac, 65 kAIC at 480 Vac**

Ampere Rating	LS Catalog Number	LSI Catalog Number	LSG Catalog Number	LSIG Catalog Number	Neutral CT for LSG and LSIG ② Catalog Number
<b>Three-Pole ③</b>					
250	LGH325033G	LGH325032G	LGH325035G	LGH325036G	LGFACT250
400	LGH340033G	LGH340032G	LGH340035G	LGH340036G	LGFACT400
600	LGH360033G	LGH360032G	LGH360035G	LGH360036G	LGFACT600
630 ④	LGH363033G	LGH363032G	LGH363035G	LGH363036G	LGFACT600
<b>Four-Pole ⑤⑥</b>					
250	LGH425033G	LGH425032G	LGH425035G	LGH425036G	—
400	LGH440033G	LGH440032G	LGH440035G	LGH440036G	—
600	LGH460033G	LGH460032G	LGH460035G	LGH460036G	—
630 ④	LGH463033G	LGH463032G	LGH463035G	LGH463036G	—

**Notes**

- ① Replace suffix "G" with "W" for no line and load terminals.
- ② Required for four-wire systems if neutral protection is desired.
- ③ For two-pole applications, use two outer poles.
- ④ 630 amperes is not a UL or CSA listed rating. 600 amperes is the maximum UL and CSA listed rating for the LG.
- ⑤ Neutral protection: 4 = 0%, 6 = 60%, 7 = 100%. Electronic trip unit neutral protection is not adjustable.
- ⑥ Four-pole breakers with LSG and LSIG trip units are only available with 0% neutral protection.

**IC Rating at 415/480 V****Complete LG Breakers with Electronic Trip Unit (Includes Frame, Trip Unit, Standard Terminals and Mounting Hardware)**<sup>①</sup>See 310+ adjustability specifications on **Page V4-T2-62**.**IC Rating: 100 kAIC at 415 Vac and 480 Vac, Current Limiting Per UL 489**

Ampere Rating	LS Catalog Number	LSI Catalog Number	LSG Catalog Number	LSIG Catalog Number	Neutral CT for LSG and LSIG <sup>②</sup> Catalog Number
<b>Three-Pole <sup>③</sup></b>					
250	LGC325033G	LGC325032G	LGC325035G	LGC325036G	LGFACT250
400	LGC340033G	LGC340032G	LGC340035G	LGC340036G	LGFACT400
600	LGC360033G	LGC360032G	LGC360035G	LGC360036G	LGFACT600
630 <sup>④</sup>	LGC363033G	LGC363032G	LGC363035G	LGC363036G	LGFACT600
<b>Four-Pole <sup>⑤⑥</sup></b>					
250	LGC425033G	LGC425032G	LGC425035G	LGC425036G	—
400	LGC440033G	LGC440032G	LGC440035G	LGC440036G	—
600	LGC460033G	LGC460032G	LGC460035G	LGC460036G	—
630 <sup>④</sup>	LGC463033G	LGC463032G	LGC463035G	LGC463036G	—

**IC Rating: 150 kAIC at 415 Vac and 480 Vac, Current Limiting Per UL 489**

Ampere Rating	LS Catalog Number	LSI Catalog Number	LSG Catalog Number	LSIG Catalog Number	Neutral CT for LSG and LSIG <sup>②</sup> Catalog Number
<b>Three-Pole <sup>③</sup></b>					
250	LGU325033G	LGU325032G	LGU325035G	LGU325036G	LGFACT250
400	LGU340033G	LGU340032G	LGU340035G	LGU340036G	LGFACT400
600	LGU360033G	LGU360032G	LGU360035G	LGU360036G	LGFACT600
630 <sup>④</sup>	LGU363033G	LGU363032G	LGU363035G	LGU363036G	LGFACT600
<b>Four-Pole <sup>⑤</sup></b>					
250	LGU425033G	LGU425032G	LGU425035G	LGU425036G	—
400	LGU440033G	LGU440032G	LGU440035G	LGU440036G	—
600	LGU460033G	LGU460032G	LGU460035G	LGU460036G	—
630 <sup>④</sup>	LGU463033G	LGU463032G	LGU463035G	LGU463036G	—

**IC Rating: 200 kAIC at 415 Vac and 480 Vac, Current Limiting Per UL 489**

Ampere Rating	LS Catalog Number	LSI Catalog Number	LSG Catalog Number	LSIG Catalog Number	Neutral CT for LSG and LSIG <sup>②</sup> Catalog Number
<b>Three-Pole <sup>③</sup></b>					
250	LGX325033G	LGX325032G	LGX325035G	LGX325036G	LGFACT250
400	LGX340033G	LGX340032G	LGX340035G	LGX340036G	LGFACT400
600	LGX360033G	LGX360032G	LGX360035G	LGX360036G	LGFACT600
630 <sup>④</sup>	LGX363033G	LGX363032G	LGX363035G	LGX363036G	LGFACT600
<b>Four-Pole <sup>⑤</sup></b>					
250	LGX425033G	LGX425032G	LGX425035G	LGX425036G	—
400	LGX440033G	LGX440032G	LGX440035G	LGX440036G	—
600	LGX460033G	LGX460032G	LGX460035G	LGX460036G	—
630 <sup>④</sup>	LGX463033G	LGX463032G	LGX463035G	LGX463036G	—

**Notes**

- ① Replace suffix "G" with "W" for no line and load terminals.
- ② Required for four-wire systems if neutral protection is desired.
- ③ For two-pole applications, use two outer poles.
- ④ 630 amperes is not a UL or CSA listed rating. 600 amperes is the maximum UL and CSA listed rating for the LG.
- ⑤ Neutral protection: 4 = 0%, 6 = 60%, 7 = 100%. Electronic trip unit neutral protection is not adjustable.
- ⑥ Four-pole breakers with LSG and LSIG trip units are only available with 0% neutral protection.

**LG 100% Rated Circuit Breaker—Thermal-Magnetic Trip Unit****Complete Breaker (Includes Frame, Trip Unit, Standard Terminals and Mounting Hardware)****LG-Frame**

**LG-Frame—630 Amperes (600 Amperes UL, CSA) IC Rating: 35 kAIC at 415 and 480 Vac** <sup>①</sup>

Ampere Rating	Three-Pole <sup>②</sup> Fixed Thermal, Adjustable Magnetic Catalog Number
250	LGE3250FAGC
300	LGE3300FAGC
320	—
350	LGE3350FAGC
400	LGE3400FAGC
500	LGE3500FAGC
600	LGE3600FAGC
630 <sup>④</sup>	—

**LG-Frame—630 Amperes (600 Amperes UL, CSA) IC Rating: 50 kAIC at 415 and 480 Vac** <sup>①</sup>

Ampere Rating	Three-Pole <sup>②</sup> Fixed Thermal, Adjustable Magnetic Catalog Number
250	LGS3250FAGC
300	LGS3300FAGC
320	—
350	LGS3350FAGC
400	LGS3400FAGC
500	LGS3500FAGC
600	LGS3600FAGC
630 <sup>④</sup>	—

**LG-Frame—630 Amperes (600 Amperes UL, CSA) IC Rating: 70 kAIC at 415, 65 kAIC at 480 Vac** <sup>①</sup>

Ampere Rating	Three-Pole <sup>②</sup> Fixed Thermal, Adjustable Magnetic Catalog Number
250	LGH3250FAGC
300	LGH3300FAGC
320	—
350	LGH3350FAGC
400	LGH3400FAGC
500	LGH3500FAGC
600	LGH3600FAGC
630 <sup>④</sup>	—

**Notes**

- <sup>①</sup> Replace suffix "G" with "W" for no line and load terminals.  
<sup>②</sup> For two-pole applications, use two outer poles.

**LG 100% Rated Electronic Breaker Per UL 489**See 310+ adjustability specifications on **Page V4-T2-62**.

2

**IEC/UL/CSA 35 kAIC at 415 and 480 Vac**

Ampere Rating	LS Catalog Number	LSI Catalog Number	LSG Catalog Number	LSIG Catalog Number	Neutral CT for LSG and LSIG <sup>①</sup> Catalog Number
250	LGE325033GC	LGE325032GC	LGE325035GC	LGE325036GC	LGFACT250
400	LGE340033GC	LGE340032GC	LGE340035GC	LGE340036GC	LGFACT400
600	LGE360033GC	LGE360032GC	LGE360035GC	LGE360036GC	LGFACT600
630 <sup>②</sup>	LGE363033GC	LGE363032GC	LGE363035GC	LGE363036GC	LGFACT600

**IEC/UL/CSA 50 kAIC at 415 and 480 Vac**

Ampere Rating	LS Catalog Number	LSI Catalog Number	LSG Catalog Number	LSIG Catalog Number	Neutral CT for LSG and LSIG <sup>①</sup> Catalog Number
250	LGS325033GC	LGS325032GC	LGS325035GC	LGS325036GC	LGFACT250
400	LGS340033GC	LGS340032GC	LGS340035GC	LGS340036GC	LGFACT400
600	LGS360033GC	LGS360032GC	LGS360035GC	LGS360036GC	LGFACT600
630 <sup>②</sup>	LGS363033GC	LGS363032GC	LGS363035GC	LGS363036GC	LGFACT600

**IEC/UL/CSA 70 kAIC at 415 and 480 Vac**

Ampere Rating	LS Catalog Number	LSI Catalog Number	LSG Catalog Number	LSIG Catalog Number	Neutral CT for LSG and LSIG <sup>①</sup> Catalog Number
250	LGH325033GC	LGH325032GC	LGH325035GC	LGH325036GC	LGFACT250
400	LGH340033GC	LGH340032GC	LGH340035GC	LGH340036GC	LGFACT400
600	LGH360033GC	LGH360032GC	LGH360035GC	LGH360036GC	LGFACT600
630 <sup>②</sup>	LGH363033GC	LGH363032GC	LGH363035GC	LGH363036GC	LGFACT600

**Notes**<sup>①</sup> Required for four-wire systems if neutral protection is required.<sup>②</sup> 630 amperes is not a UL or CSA listed rating. 600 amperes is the maximum UL and CSA listed rating for the LG.

**LG Electronic Breaker with Arcflash Reduction Maintenance System**

See 310+ adjustability specifications on **Page V4-T2-62**.

Series G LG circuit breakers are available with the Arcflash Reduction Maintenance System™ integrated into the electronic trip units helping to improve safety by providing a

simple and reliable method to reduce fault clearing time. The Arcflash Reduction Maintenance System unit utilizes a separate analog trip circuit that provides faster

interruption times than the standard (digital) “instantaneous” protection. Work locations downstream of a circuit breaker with an Arcflash Reduction

Maintenance System unit can have a significantly lower incident energy level, reducing arc flash potential to the system.

**LG with Arcflash Reduction Maintenance System****LG Electronic Breaker with Arcflash Reduction Maintenance System**

Ampere Rating	ALSI Catalog Number	ALSIG Catalog Number	Neutral CT for LSG and LSIG ① Catalog Number
<b>IEC/UL/CSA 35 kAIC at 415 and 480 Vac</b>			
250	LGE325038G	LGE365039G	LGFACT250
400	LGE340038G	LGE340039G	LGFACT400
600	LGE360038G	LGE360039G	LGFACT600
630	LGE363038G	LGE363039G	LGFACT600
<b>IEC/UL/CSA 50 kAIC at 415 and 480 Vac</b>			
250	LGS325038G	LGS365039G	LGFACT250
400	LGS340038G	LGS340039G	LGFACT400
600	LGS360038G	LGS360039G	LGFACT600
630	LGS363038G	LGS363039G	LGFACT600
<b>IEC/UL/CSA 70 kAIC at 415 and 480 Vac</b>			
250	LGH325038G	LGH365039G	LGFACT250
400	LGH340038G	LGH340039G	LGFACT400
600	LGH360038G	LGH360039G	LGFACT600
630	LGH363038G	LGH363039G	LGFACT600
<b>IEC/UL/CSA 100 kAIC at 415 and 480 Vac, Current Limiting Per UL 489</b>			
250	LGC325038G	LGC365039G	LGFACT250
400	LGC340038G	LGC340039G	LGFACT400
600	LGC360038G	LGC360039G	LGFACT600
630	LGC363038G	LGC363039G	LGFACT600
<b>IEC/UL/CSA 150 kAIC at 415 and 480 Vac, Current Limiting Per UL 489</b>			
250	LGU325038G	LGU365039G	LGFACT250
400	LGU340038G	LGU340039G	LGFACT400
600	LGU360038G	LGU360039G	LGFACT600
630	LGU363038G	LGU363039G	LGFACT600
<b>IEC/UL/CSA 200 kAIC at 415 and 480 Vac, Current Limiting Per UL 489</b>			
250	LGX325038G	LGX365039G	LGFACT250
400	LGX340038G	LGX340039G	LGFACT400
600	LGX360038G	LGX360039G	LGFACT600
630	LGX363038G	LGX363039G	LGFACT600

**LG Electronic Trip Units with Arcflash Reduction Maintenance System**

Ampere Rating	ALSI Catalog Number	ALSIG Catalog Number	Neutral CT for LSG and LSIG ① Catalog Number
250	LT325038	LT325039	LGFACT250
400	LT340038	LT340039	LGFACT400
600	LT360038	LT360039	LGFACT600
630	LT363038	LT363039	LGFACT600

**Note**

① Required for four-wire systems if neutral protection is required.

## Accessories Selection Guide and Ordering Information

## 2

## Line and Load Terminals

Maximum Breaker Amperes	Terminal Body Material	Wire Type	AWG Wire Range/ Number of Conductors	Metric Wire Range (mm <sup>2</sup> )	Number of Terminals Included	Catalog Number
400	Aluminum	Cu/Al	500–750 (1)	240–380 (1)	3	3TA631LK <sup>①</sup>
400	Aluminum	Cu/Al	500–750 (1)	240–380 (1)	4	4TA631LK <sup>①</sup>
400	Copper	Cu	500–750 (1)	240–380 (1)	3	3T631LK <sup>①</sup>
400	Copper	Cu	500–750 (1)	240–380 (1)	4	4T631LK <sup>①</sup>
630	Aluminum	Cu/Al	2–500 (2)	35–240 (2)	1	TA632L
630	Aluminum	Cu/Al	2–500 (2)	35–240 (2)	3	3TA632LK <sup>①②</sup>
630	Aluminum	Cu/Al	2–500 (2)	35–240 (2)	4	4TA632LK <sup>①②</sup>
630	Copper	Cu	2–500 (2)	35–240 (2)	3	3T632LK <sup>①</sup>
630	Copper	Cu	2–500 (2)	35–240 (2)	4	4T632LK <sup>①</sup>
400	Aluminum	Cu/Al	3–500 (1)	35–240 (1)	1	TA350LK <sup>②</sup>
400	Copper	Cu	3–500 (1)	35–240 (1)	1	T350LK

## Base Mounting Hardware

Base mounting hardware is included with a circuit breaker or molded case switch. (Included with breaker.) If required separately, order 66A4560G03.

## Terminal Covers

Description	Catalog Number
Three-pole terminal cover <sup>③</sup>	LTS3K
Four-pole terminal cover <sup>③</sup>	LTS4K

## End Cap Kits (MIO Metric Nuts)

Number of Poles	Catalog Number
3	L3RTWK
4	L4RTWK

## Control Wire Terminal Kit

Description	Terminal Body Type	Catalog Number
Three-pole kit	Aluminum	3TA632LKW
Four-pole kit	Aluminum	4TA632LKW
Three-pole kit	Copper	3T632LKW
Four-pole kit	Copper	4T632LKW

## Terminal Spreaders

Number of Poles	Catalog Number
3	LGTEW3
4	LGTEW4

## Terminal Extensions

Number of Poles	Catalog Number
3	LGTES3
4	LGTES4

## Handle Extension

Description	Catalog Number
Handle extension	HEXLG

## Interphase Barrier

Package of 2	Catalog Number
Interphase barrier	IPB3

## Rear Fed Terminals

Maximum Amperes	Wire Size Range AWG Cu	Catalog Number
400	2–500 kcmil	TA350LKRF
400	2–500 kcmil	3TA350LKRF
630	2–500 (2) kcmil	TA632LKRF
630	2–500 (2) kcmil	3TA632LKRF

Rear fed terminals allow the cable to connect to the breaker from the back instead of the top. Terminal shields or interphase barriers are included with each rear fed terminal kit (depending on frame size). When catalog number starts with a 3, it indicates a kit with three terminals in each kit. Catalog number beginning with a TA indicates one terminal.

## Multiwire Connectors

Field-installed multiwire connectors for the load side (OFF) end terminals are used to distribute the load from the circuit breaker to multiple devices without the use of separate distribution terminal blocks.

Multiwire lug kits include terminal shield, mounting hardware, insulators and tin-plated aluminum connectors to replace three mechanical load lugs. UL listed as used on the load side (OFF) end.

## LG-Frame Multiwire Connectors Ordering Information (Package of 3)

Maximum Amperes	Wires per Terminal	Wire Size Range AWG Cu	Kit Catalog Number
600	6	14–1/0	3TA600L6K

## Notes

- ① Includes LTS3K (three-pole) or LTS4K (four-pole) terminal covers.
- ② Standard terminal included with complete breaker.
- ③ Included in TA631L, T631L, TA632L kits listed above.

**Terminals and Terminal Cover for the LG Breaker—Includes LTS3K (Three-Pole) or LTS4K (Four-Pole) Terminal Covers**

**Note:** Extended terminal covers add 2.13 inches (54.0 mm) to breaker length.

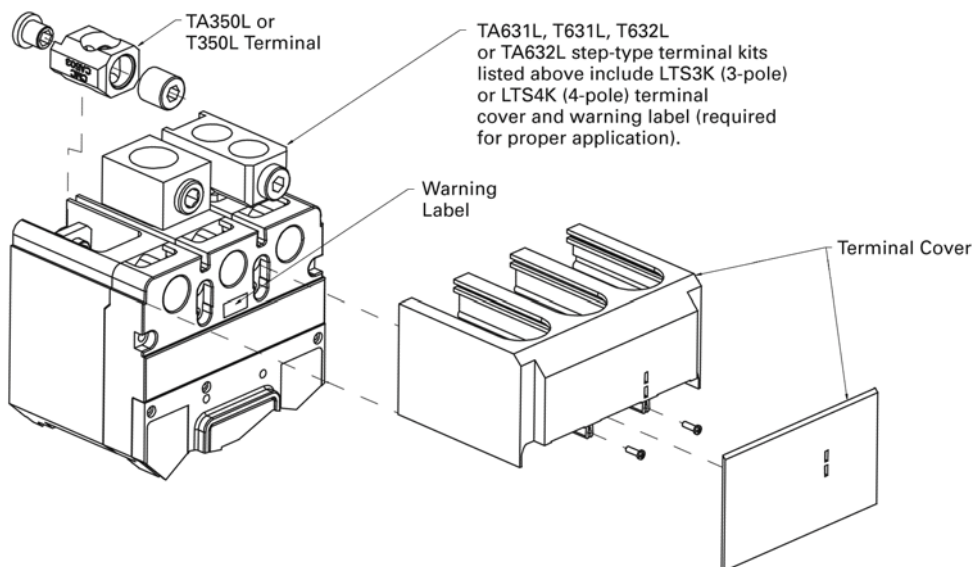

## Accessories

## 2

**Base Mounting Hardware**

Base mounting hardware is included with a circuit breaker or molded case switch. (Included with breaker.) If required separately, order 66A4560G03.

**Allowable Accessory Combinations**

Different combinations of accessories can be supplied, depending on the types of accessories and the number of poles in the circuit breaker.

**LG-Frame Accessories**

Description	Reference Page	Three-Pole			Four-Pole			Neu.
		Left	Center	Right	Left	Center	Right	
<b>Internal Accessories (Only One Internal Accessory Per Pole)</b>								
Alarm lockout (Make/Break)	V4-T2-109			■			■	
Auxiliary switch (1A, 1B)	V4-T2-109			■			■	
Auxiliary switch (2A, 2B)	V4-T2-109			■			■	
Auxiliary switch and alarm switch combination	V4-T2-109			■			■	
Shunt trip—standard	V4-T2-109	■			■			
Undervoltage release mechanism	V4-T2-110	■			■			
<b>External Accessories</b>								
End cap kit	V4-T2-58	●			●			
Handle extension	V4-T2-58	●			●			
Terminal cover	V4-T2-58	●			●			
Rear fed terminals	V4-T2-58	●	●	●	●	●	●	●
Multewire connectors	V4-T2-58	●	●	●	●	●	●	●
Padlockable handle block	V4-T2-107		■			■		
Padlockable handle lock hasp	V4-T2-107	□		□	□		□	
Key interlock kit	V4-T2-107	□		□	□		□	
Sliding bar interlock—requires two breakers	V4-T2-107	●	●	●	●	●	●	●
Electrical operator	V4-T2-107	●	●	●	●	●	●	●
Plug-in adapters	V4-T2-107	●	●	●	●	●	●	●
Rear connecting studs	V4-T2-107	●	●	●	●	●	●	●
Handle mechanisms	V4-T2-420	●	●	●	●	●	●	●
Earth leakage/ground fault protector	V4-T2-92	●	●	●	●	●	●	●
Drawout cassette	V4-T2-115	●	●	●	●	●	●	●
Digitrip 310+ test kit	V4-T2-52	●	●	●	●	●	●	●
Ammeter/cause of trip display	V4-T2-106	●	●	●	●	●	●	●
Cause of trip LED module	V4-T2-106	●	●	●	●	●	●	●
<b>Modifications (Refer to Eaton)</b>								
Moisture fungus treatment	V4-T2-105	●	●	●	●	●	●	●
Freeze-tested circuit breakers	—	●	●	●	●	●	●	●
Marine/naval application, UL 489 Supplement SA and SB	①	●	●	●	●	●	●	●

**Legend**

- Applicable in indicated pole position
- May be mounted on left or right pole—not both
- Accessory available/modification available

**Note**

① Contact Eaton.

## Technical Data and Specifications

### Interrupting Capacity Ratings

#### UL 489/IEC 60947-2 Interrupting Capacity Ratings

Circuit Breaker Type	Number of Poles	Interrupting Capacity (kA rms Symmetrical Amperes) (kA)								Volts DC <sup>①</sup>	
		Volts AC (50/60 Hz)								250 <sup>②③</sup>	
		240–240		380–415		480	600	690	lcs	lcs	lcs
LGE630	3, 4	65	65	35	35	35	18	12	6	22	22
LGS630	3, 4	85	85	50	50	50	25	20	10	22	22
LGH630	3, 4	100	100	70	70	65	35	25	13	42	42
LGC630 <sup>④</sup>	3, 4	200	200	100	100	100	50	30	15	42	42
LGU630 <sup>④</sup>	3, 4	200	200	150	150	150	65	35	18	50	50
LGX630 <sup>④</sup>	3, 4	200 <sup>⑤</sup>	200	200	200	200	65	35	18	50	50

#### UL 489 Current Limiting Data

Frame	Circuit	I <sub>p</sub> (kA)	I <sup>2</sup> T (10 <sup>6</sup> A <sup>2</sup> S)
LGC	240 V/200 kA	56.4	5.873
LGC	480 V/100 kA	56.4	5.873
LGC	600 V/50 kA	56.4	6.690
LGU	240 V/200 kA	77.7	7.320
LGU	480 V/150 kA	77.7	7.320
LGU	600 V/65 kA	50.6	6.690
LGX	240 V/200 kA	77.7	7.320
LGX	480 V/200 kA	77.7	7.320
LGX	600 V/65 kA	50.6	6.690

#### LG 310+ Specifications

Description	Specification
Trip Unit Type	Digitrip RMS 310+
<b>Breaker Type</b>	
Frame designation	LG
Frames available	250 A, 400 A, 600 A
Continuous current range (A)	100–600 A
Ground fault pickup (A)	50–600 A
Interrupting capacities at 480 Vac (kAIC)	35, 65, 100, 150, 200
100% rated	Yes
<b>Protection</b>	
Ordering options	LS, LSI, LSG, LSIG, ALSI, ALSIG
Arcflash reduction maintenance system (or maintenance mode)	Yes
Interchangeable trip unit	Yes
High load alarm (suffix B20) <sup>⑤</sup>	Yes
Ground fault alarm with trip (suffix B21) <sup>⑤</sup>	Yes
Ground fault alarm, no trip (suffix B22) <sup>⑤</sup>	Yes
Zone selective interlocking (suffix ZG)	LSI, LSIG, ALSI, ALSIG
Cause of trip indication	Yes
Thru-cover accessories	Yes

#### Notes

- ① DC rating apply to substantially non-inductive circuits.
- ② Two-pole circuit breaker, or two poles of three-pole circuits.
- ③ Time constant is 3 milliseconds minimum at 10 kA and 8 milliseconds minimum at –kA.
- ④ Current limiting per UL 489.
- ⑤ B2x suffixes cannot be combined with B2x suffixes.

# 2.2

## Molded Case Circuit Breakers

### Series G

#### LG 310+ Adjustability Specifications

2

310+ Settings		LG Frame		
		250 A	400 A	600 A
$I_r$ = continuous current or long delay pickup (amperes) (All 310+)	$I_r$			
	A	100	160	250
	B	125	200	300
	C	150	225	315
	D	160	250	350
	E	175	300	400
	F	200	315	450
	G	225	350	500
	H (= $I_n$ )	250	400	600
$t_r$ = long delay time (seconds) (All 310+)	Position 1	2	2	2
	Position 2	4	4	4
	Position 3	7	7	7
	Position 4	10	10	10
	Position 5	12	12	12
	Position 6	15	15	15
	Position 7	20	20	20
	Position 8	24	24	24
	$I_{sd}$ (x $I_r$ ) = short delay pickup (All 310+)	Position 1	2x	2x
Position 2		3x	3x	3x
Position 3		4x	4x	4x
Position 4		5x	5x	5x
Position 5		6x	6x	6x
Position 6		7x	7x	7x
Position 7		8x	8x	8x
Position 8		10x	10x	10x
Position 9		12x	12x	12x
$t_{sd}$ = short delay time $I^2t$ (milliseconds) (LS, LSG)	Fixed	67 at10x	67 at10x	67 at10x
$t_{sd}$ = short delay time flat (milliseconds) ① (LSI, LSIG, ALSI, ALSIG)	Position 1	Inst	Inst	Inst
	Position 2	120	120	120
	Position 3	300	300	300
$I_g$ = ground fault pickup (amperes) (LSG, LSIG, ALSIG)	Position 1	50	80	120
	Position 2	75	120	180
	Position 3	100	160	240
	Position 4	150	240	360
	Position 5	200	320	480
	Position 6	250	400	600
$t_g$ = ground fault delay time (milliseconds) (LSG, LSIG, ALSIG)	Position 1	Inst	Inst	Inst
	Position 2	120	120	120
	Position 3	300	300	300
Independently Adjustable Instantaneous ( $I_i$ ) setting (ALSI, ALSIG)	Yes	2.5x, 4x, 6x, 7x, 8x, 10x, 12x	2.5x, 4x, 6x, 7x, 8x, 10x, 12x	2.5x, 4x, 6x, 7x, 8x, 10x, 12x
Maintenance Mode (remote) pickup ( $2.5 \times I_n$ ) ② (ALSI, ALSIG)	Fixed	2.5x		

#### Notes

① 50 ms for ALSI and ALSIG trip units.

② Maintenance Mode is enabled remotely using a 24 Vdc circuit.

## Dimensions and Weights

Approximate Dimensions in Inches (mm)

### LG-Frame

Number of Poles	Width	Height	Depth
2, 3	5.48 (139.2)	10.13 (257.3)	4.09 (103.9)
4	7.22 (183.4)	10.13 (257.3)	4.09 (103.9)

### LG-Frame

**Note:** TA631L, T631L, T632L, TA632L terminals add 1.19 inches (30.2 mm) to line or load side of LG. LTS3K or LTS4K terminal covers add 2.13 inches (54.1 mm) to line or load side of LG.

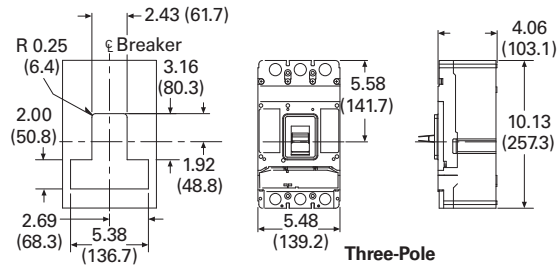

Approximate Shipping Weight in Lbs (kg)

### LG-Frame

Breaker Type	Two- and Three-Pole	Four-Pole
LGE, LGS, LGH, LGC, LGU, LGX	16 (7.3)	20 (9.1)

### Notes

- ① DC rating apply to substantially non-inductive circuits.
- ② Two-pole circuit breaker, or two poles of three-pole circuits.
- ③ Time constant is 3 milliseconds minimum at 10 kA and 8 milliseconds minimum at -kA.
- ④ Three-poles in series. 750 Vdc ratings available (four-pole in series, not UL listed). Contact Eaton.
- ⑤ IEC rating is 300 kA at 240 Vac.
- ⑥ Current limiting per UL 489.

# 2.2

## Molded Case Circuit Breakers

### Series G

#### LG-Frame With Earth Leakage Module

2

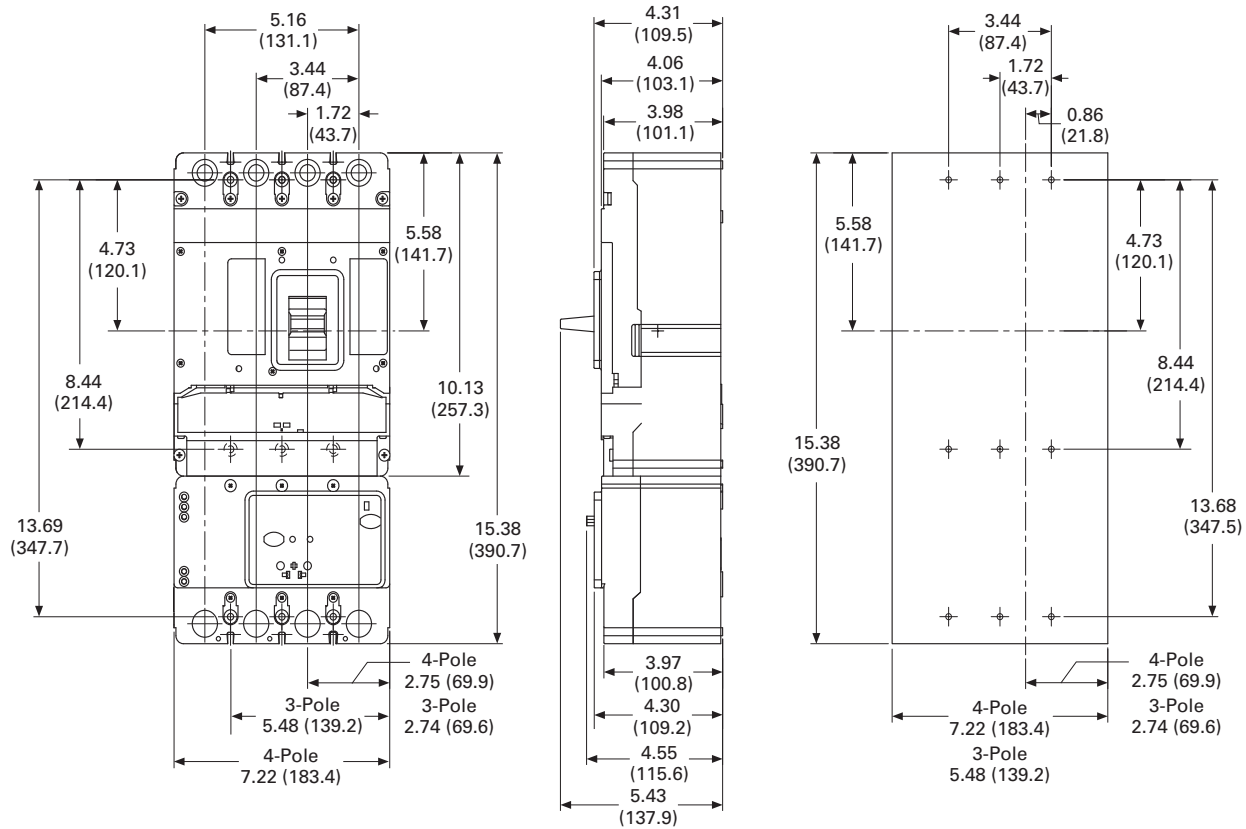

**NG-Frame (1200 Ampere)****Contents**

<b>Description</b>	<b>Page</b>
EG-Frame (15–125 Amperes) . . . . .	<b>V4-T2-15</b>
JG-Frame (63–250 Amperes) . . . . .	<b>V4-T2-29</b>
LG-Frame (250–630 Amperes) . . . . .	<b>V4-T2-47</b>
NG-Frame (320–1200 Amperes)	
Catalog Number Selection . . . . .	<b>V4-T2-66</b>
Product Selection Guide and Ordering Information . . . . .	<b>V4-T2-67</b>
Accessories . . . . .	<b>V4-T2-70</b>
Technical Data and Specifications . . . . .	<b>V4-T2-71</b>
Dimensions and Weights . . . . .	<b>V4-T2-73</b>
RG-Frame (800–2500 Amperes) . . . . .	<b>V4-T2-74</b>
Motor Circuit Protectors (MCP) . . . . .	<b>V4-T2-85</b>
Motor Protector Circuit Breakers (MPCB) . . . . .	<b>V4-T2-89</b>
30 mA Ground Fault (Earth Leakage) Module . . . . .	<b>V4-T2-92</b>
Current Limiting Circuit Breaker Module . . . . .	<b>V4-T2-96</b>
High Instantaneous Circuit Breaker for Selective Coordination . . . . .	<b>V4-T2-101</b>
Special Features and Accessories . . . . .	<b>V4-T2-104</b>
Motor Operators . . . . .	<b>V4-T2-112</b>
Plug-In Blocks . . . . .	<b>V4-T2-114</b>
Drawout Cassette . . . . .	<b>V4-T2-115</b>

**NG-Frame (320–1200 Amperes)****Product Description**

- All Eaton NG-Frame circuit breakers are suitable for reverse feed use
- All NG-Frame circuit breakers are HACR rated

#### Catalog Number Selection

This information is presented only as an aid to understanding catalog numbers. It is not to be used to build catalog numbers for circuit breakers or trip units.

2

#### NG Circuit Breaker with 310+ Electronic Trip Unit

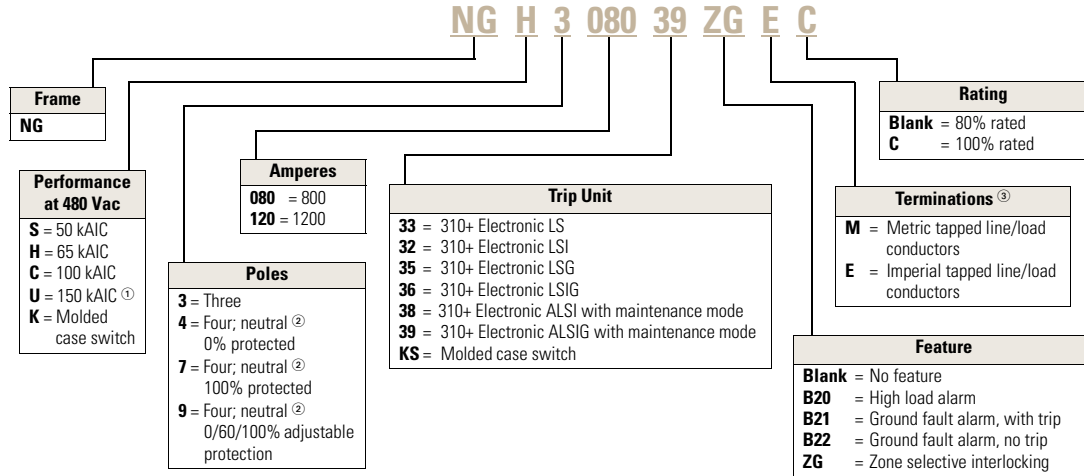

#### Notes

- ① 800 A only.
  - ② Neutral inn left pole on GN; right pole on NG.
  - ③ Breakers do not ship with lugs.
- Trip units are factory installable only.

## Product Selection Guide and Ordering Information

### Type NGS Standard Interrupting Capacity— $U_e$ Max. 690 Vac, 50 kA $I_{cu}$ at 480 Vac or 415 Vac

See 310+ adjustability specifications on [Page V4-T2-72](#).

Maximum Continuous Ampere Rating at 40 °C <sup>①②</sup>	Number of Poles	Circuit Breaker Frame Including Digitrip Electronic Trip Unit with Imperial Tapped Conductors						Neutral CT for LSG and LSIG <sup>③</sup>
		LS	LSI	LSG	LSIG	ALSI	ALSIG	
800	3	NGS308033E	NGS308032E	NGS308035E	NGS308036E	NGS308038E	NGS308039E	NGFCT120
	4	NGS408033E	NGS408032E	NGS408035E <sup>④</sup>	NGS408036E <sup>④</sup>	NGS408038E	NGS408039E <sup>④</sup>	—
	4 <sup>⑤</sup>	NGS708033E	NGS708032E	—	—	NGS708038E	—	—
	4 <sup>⑥</sup>	NGS908033E	NGS908032E	—	—	NGS908038E	—	—
1200 <sup>⑥</sup>	3	NGS312033E	NGS312032E	NGS312035E	NGS312036E	NGS312038E	NGS312039E	NGFCT120
	4	NGS412033E	NGS412032E	NGS412035E <sup>④</sup>	NGS412036E <sup>④</sup>	—	NGS412039E <sup>④</sup>	—
	4 <sup>⑤</sup>	NGS712033E	NGS712032E	—	—	NGS712038E	—	—
	4 <sup>⑥</sup>	NGS912033E	NGS912032E	—	—	NGS912038E	—	—

### Type NGS Standard Interrupting Capacity— $U_e$ Max. 690 Vac, 50 kA $I_{cu}$ at 415 Vac

See 310+ adjustability specifications on [Page V4-T2-72](#).

Maximum Continuous Ampere Rating at 40 °C <sup>①②</sup>	Number of Poles	Circuit Breaker Frame Including Digitrip Electronic Trip Unit with Metric Tapped Conductors						Neutral CT for LSG and LSIG <sup>③</sup>
		LS	LSI	LSG	LSIG	ALSI	ALSIG	
800	3	NGS308033M	NGS308032M	NGS308035M	NGS308036M	NGS308038M	NGS308039M	NGFCT120
	4	NGS408033M	NGS408032M	NGS408035M <sup>④</sup>	NGS408036M <sup>④</sup>	NGS408038M	NGS408039M <sup>④</sup>	—
	4 <sup>⑤</sup>	NGS708033M	NGS708032M	—	—	NGS708038M	—	—
	4 <sup>⑥</sup>	NGS908033M	NGS908032M	—	—	NGS908038M	—	—
1200	3	NGS312033M	NGS312032M	NGS312035M	NGS312036M	NGS312038M	NGS312039M	NGFCT120
	4	NGS412033M	NGS412032M	NGS412035M <sup>④</sup>	NGS412036M <sup>④</sup>	—	NGS412039M <sup>④</sup>	—
	4 <sup>⑤</sup>	NGS712033M	NGS712032M	—	—	NGS712038M	—	—
	4 <sup>⑥</sup>	NGS912033M	NGS912032M	—	—	NGS912038M	—	—

## Molded Case Switches <sup>⑧⑨</sup>

$U_e$  Maximum 690 Vac

Ampere Rating	Three-Pole	Catalog Number	Four-Pole	Catalog Number
800	MCS with Imperial line and load terminals	NGK3080KSE	MCS with Imperial line and load terminals	NGK4080KSE
1200	MCS with Imperial line and load terminals	NGK3120KSE	MCS with Imperial line and load terminals	NGK4120KSE
1250	MCS with Imperial line and load terminals	NGK3125KSE	MCS with Imperial line and load terminals	NGK43125KSE

### Notes

- ① For AC use only.
- ② NG MCCBs are suitable for 40 °C or 50 °C applications. Order suffix V3 to eliminate standard 40 °C labeling.
- ③ Required for four-wire systems if neutral protection is desired. Sold separately.
- ④ Neutral 0% protected. NG, neutral in right pole; GN, neutral in left pole.
- ⑤ Neutral 100% protected (denoted by 7 in digit four); no neutral protection available with LSG or LSIG trip units.
- ⑥ Neutral 0%/60%/100% adjustable protection (denoted by 9 in digit four).
- ⑦ Non-UL listed NG 1250 with 1250 ampere trip unit is also available.
- ⑧ For AC use only. Molded case switch will trip above 14,000 amperes.
- ⑨ For two-pole applications, use outer poles of three-pole molded case switch.

**Type NGH High Interrupting Capacity— $U_e$  Max. 690 Vac, 65 kA  $I_{cu}$  at 480 Vac or 415 Vac**See 310+ adjustability specifications on **Page V4-T2-72**.

2

Maximum Continuous Ampere Rating at 40 °C <sup>①②</sup>	Number of Poles	Circuit Breaker Frame Including Digitrip Electronic Trip Unit						Neutral CT for LSG and LSIG <sup>③</sup>
		LS	LSI	LSG	LSIG	ALSI	ALSIG	
800	3	NGH308033E	NGH308032E	NGH308035E	NGH308036E	NGH308038E	NGH308039E	NGFCT120
	4	NGH408033E	NGH408032E	NGH408035E <sup>④</sup>	NGH408036E <sup>④</sup>	NGH408038E	NGH408039E <sup>④</sup>	—
	4 <sup>⑤</sup>	NGH708033E	NGH708032E	—	—	NGH708038E	—	—
	4 <sup>⑥</sup>	NGH908033E	NGH908032E	—	—	NGH908038E	—	—
1200	3	NGH312033E	NGH312032E	NGH312035E	NGH312036E	NGH312038E	NGH312039E	NGFCT120
	4	NGH412033E	NGH412032E	NGH412035E <sup>④</sup>	NGH412036E <sup>④</sup>	—	NGH412039E <sup>④</sup>	—
	4 <sup>⑤</sup>	NGH712033E	NGH712032E	—	—	NGH712038E	—	—
	4 <sup>⑥</sup>	NGH912033E	NGH912032E	—	—	NGH912038E	—	—

**Type NGC Very High Capacity— $U_e$  Max. 690 Vac, 100 kA  $I_{cu}$  at 480 Vac or 415 Vac**See 310+ adjustability specifications on **Page V4-T2-72**.

Maximum Continuous Ampere Rating at 40 °C <sup>①②</sup>	Number of Poles	Circuit Breaker Frame Including Digitrip Electronic Trip Unit						Neutral CT for LSG and LSIG <sup>③</sup>
		LS	LSI	LSG	LSIG	ALSI	ALSIG	
800	3	NGC308033E	NGC308032E	NGC308035E	NGC308036E	NGC308038E	NGC308039E	NGFCT120
	4	NGC408033E	NGC408032E	NGC408035E <sup>④</sup>	NGC408036E <sup>④</sup>	NGC408038E	NGC408039E <sup>④</sup>	—
	4 <sup>⑤</sup>	NGC708033E	NGC708032E	—	—	NGC708038E	—	—
	4 <sup>⑥</sup>	NGC908033E	NGC908032E	—	—	NGC908038E	—	—
1200	3	NGC312033E	NGC312032E	NGC312035E	NGC312036E	NGC312038E	NGC312039E	NGFCT120
	4	NGC412033E	NGC412032E	NGC412035E <sup>④</sup>	NGC412036E <sup>④</sup>	—	NGC412039E <sup>④</sup>	—
	4 <sup>⑤</sup>	NGC712033E	NGC712032E	—	—	NGC712038E	—	—
	4 <sup>⑥</sup>	NGC912033E	NGC912032E	—	—	NGC912038E	—	—

**Notes**

- ① For AC use only.
- ② NG MCCBs are suitable for 40 °C or 50 °C applications. Order suffix V3 to eliminate standard 40 °C labeling.
- ③ Required for four-wire systems if neutral protection is desired. Sold separately.
- ④ Neutral 0% protected. NG, neutral in right pole; GN, neutral in left pole.
- ⑤ Neutral 100% protected (denoted by 7 in digit four); no neutral protection available with LSG or LSIG trip units.
- ⑥ Neutral 0%/60%/100% adjustable protection (denoted by 9 in digit four).

## Accessories Selection Guide and Ordering Information

### Line and Load Terminals

N-Frame circuit breakers do not include terminals as standard. When copper or Cu/Al terminals are required, order by catalog number.

### Line and Load Terminals

Maximum Breaker Amperes	Terminal Body Material	Wire Type	AWG Wire (Number of Conductors)	AWG Wire Catalog Number <sup>①</sup>	Metric Wire Range mm <sup>2</sup>	Metric Catalog Number <sup>①</sup>
<b>Standard Cu/Al Pressure Terminals</b>						
700	Aluminum	Cu/Al	1–500 (2)	<b>TA700NB1</b>	50–240	<b>TA700NB1M</b>
1000	Aluminum	Cu/Al	3/0–400 (3)	<b>TA1000NB1</b>	95–185	<b>TA1000NB1M</b>
1200	Aluminum	Cu/Al	4/0–500 (4)	<b>TA1200NB1</b>	120–240	<b>TA1200NB1M</b>
1200	Aluminum	Cu/Al	500–750 (3)	<b>TA1201NB1</b>	300–400	<b>TA1201NB1M</b>
<b>Optional Copper and Cu/Al Pressure Type Terminals</b>						
700	Copper	Cu	2/0–500 (2)	<b>T700NB1</b>	70–240	<b>T700NB1M</b>
1000	Copper	Cu	3/0–500 (3)	<b>T1000NB1</b>	95–240	<b>T1000NB1M</b>
1200	Copper	Cu	3/0–400 (4)	<b>T1200NB3</b>	95–185	<b>T1200NB3M</b>

### 310+ Electronic Trip Unit Accessories

Description	Catalog Number
Electronic portable test kit	<b>MTST230V</b>
Trip unit tamper protection wire seal	<b>5108A03H01</b>
External neutral sensor (1200 A) <sup>②</sup>	<b>NGFCT120</b>
External neutral sensor (800 A) <sup>②</sup>	<b>NGFCT120</b>
Breaker-mount cause-of-trip indication	<b>TRIP-LED</b>
Breaker-mount ammeter module	<b>DIGIVIEW</b>
Remote-mount ammeter module	<b>DIGIVIEWR06</b>

### Base Mounting Hardware

Base mounting hardware is included with a circuit breaker or molded case switch.

### Base Mounting Hardware <sup>③</sup>

Number of Poles	Description	Catalog Number
Three- and four-pole	Imperial hardware: 0.3125–18 x 1.25 pan-head steel screws and lock washers	<b>BMH5</b>
Three- and four-pole	Metric hardware: M8 pan-head steel screws and lock washers	<b>BMH5M</b>

### Terminal Shield

### Terminal Shield

Description	Catalog Number
Three-pole terminal shield	<b>NTS3K</b>

### Conductor Extension Kit

### Conductor Extension Kit <sup>④</sup>

Description	Catalog Number
Three-pole both ends Metric	<b>5104A24G04</b>
Three-pole both ends English	<b>5104A24G02</b>

### Keeper Nut

Not required on NG-Frame. Terminals are threaded.

### Handle Extension

Included with breaker. Additional handle extensions are available.

### Handle Extension

Description	Catalog Number
Single handle extension	<b>HEX5</b>

### Interphase Barriers

The interphase barriers provide additional electrical clearance between circuit breaker poles for special termination applications. Barriers are high dielectric insulating plates that are installed in the molded slots between the terminals. (Field installation only.)

### Interphase Barriers

Description	Catalog Number
Interphase barriers <sup>④</sup>	<b>IPB5</b>

### Notes

- <sup>①</sup> Single terminals individually packed.
- <sup>②</sup> Required for four-wire systems if neutral protection is desired. Sold separately.
- <sup>③</sup> Metric hardware included with breaker.
- <sup>④</sup> Included as standard on 100% rated 1200 A breakers only.

## Accessories

2

### Allowable Accessory Combinations

Different combinations of accessories can be supplied, depending on the types of accessories and the number of poles in the circuit breaker.

### NG-Frame Accessories

Description	Reference Page	Three-Pole			Four-Pole			Neu.
		Left	Center	Right	Left	Center	Right	
<b>Internal Accessories (Only One Internal Accessory Per Pole)</b>								
Alarm lockout (Make/Break)	V4-T2-109	●		■	●		■	
Auxiliary switch (1A, 1B)	V4-T2-109	●		■	●		■	
Auxiliary switch (2A, 2B)	V4-T2-109	●		■	●		■	
Auxiliary switch and alarm switch combination	V4-T2-109	●		■	●		■	
Shunt trip—standard	V4-T2-109	■			■			
Undervoltage release mechanism	V4-T2-110	■			■			
<b>External Accessories</b>								
Base mounting hardware	V4-T2-69	●	●	●	●	●	●	●
Interphase barriers	V4-T2-69	●	●	●	●	●	●	●
Non-padlockable handle block	V4-T2-107		■			■		
Padlockable handle lock hasp	V4-T2-107	□		□	□		□	
Key interlock kit	V4-T2-107	□		□	□		□	
Sliding bar interlock—requires two breakers	V4-T2-107	●	●	●				
Electrical operator	V4-T2-107	●	●	●	●	●	●	●
Plug-in adapters	V4-T2-114	●	●	●	●	●	●	●
Rear connecting studs	V4-T2-107	●	●	●	●	●	●	●
Handle mechanisms	V4-T2-420	●	●	●	●	●	●	●
Drawout cassette	V4-T2-115	●	●	●	●	●	●	●
Handle extension	V4-T2-69	●	●	●	●	●	●	●
Ammeter/cause of trip display	V4-T2-106	●	●	●	●	●	●	●
Cause of trip LED module	V4-T2-106	●	●	●	●	●	●	●
Digitrip 310+ test kit	V4-T2-106	●	●	●	●	●	●	●
<b>Modifications (Refer to Eaton)</b>								
Moisture fungus treatment	V4-T2-105	●	●	●	●	●	●	●
Freeze-tested circuit breakers	—	●	●	●	●	●	●	●
Marine/Naval application, UL 489 Supplement SA and SB	①	●	●	●	●	●	●	●

#### Legend

- Applicable in indicated pole position
- May be mounted on left or right pole—not both
- Accessory available/modification available

#### Note

- ① Contact Eaton.

## Technical Data and Specifications

### Interrupting Capacity Ratings

#### UL 489/IEC 60947-2 Interrupting Capacity Ratings <sup>①</sup>

Circuit Breaker Type	Number of Poles	Interrupting Capacity (kA Symmetrical Amperes)								
		Volts AC (50/60 Hz)								
		240 (UL)		220–240		380–415		690		
		I <sub>CU</sub>	I <sub>CS</sub>	I <sub>CU</sub>	I <sub>CS</sub>	480	600	I <sub>CU</sub>	I <sub>CS</sub>	
NGS <sup>①</sup>	2, 3, 4	65	85	85	50	50	50	25	20	10
NGH	2, 3, 4	100	100	100	70	50	65	35	25	13
NGC	2, 3, 4	200	200	100	100	50	100	65	35	18

### NG-Frame Digitrip Specifications

#### NG 310+ Specifications

Description	Specification
Trip Unit Type	Digitrip RMS 310+
<b>Breaker Type</b>	
Frame designation	NG
Frames available	800 A, 1200 A
Continuous current range (A)	320–1200A
Ground fault pickup (A)	160–1200A
Interrupting capacities at 480 Vac (kAIC)	35, 65, 100, 150
100% rated	Yes
<b>Protection</b>	
Ordering options	LS, LSI, LSG, LSIG, ALSI, ALSIG
Arcflash reduction maintenance system (or maintenance mode)	Yes
Interchangeable trip unit	No
High load alarm (suffix B20) <sup>②</sup>	Yes
Ground fault alarm with trip (suffix B21) <sup>②</sup>	Yes
Ground fault alarm, no trip (suffix B22) <sup>②</sup>	Yes
Zone selective interlocking (suffix ZG)	LSI, LSIG, ALSI, ALSIG
Cause of trip indication	Yes
Thru-cover accessories	No

#### Notes

<sup>①</sup> 1600 amperes is not a UL or CSA listed rating. 1200 amperes is the maximum UL and CSA rating for NG.

<sup>②</sup> B2x suffixes cannot be combined with B2x suffixes.

## NG 310+ Adjustability Specifications

2

310+ Settings	NG Frame		
	800 A	1200 A	
$I_r$ = continuous current or long delay pickup (amperes) (All 310+)	$I_r$		
	A	320	500
	B	400	600
	C	450	630
	D	500	700
	E	600	800
	F	630	900
	G	700	1000
	H (= $I_n$ )	800	1200
$t_r$ = long delay time (seconds) (All 310+)	Position 1	2	2
	Position 2	4	4
	Position 3	6	7
	Position 4	8	10
	Position 5	10	12
	Position 6	12	15
	Position 7	14	20
	Position 8	14	24
$I_{sd}$ (x $I_r$ ) = short delay pickup (All 310+)	Position 1	2x	2x
	Position 2	3x	3x
	Position 3	4x	4x
	Position 4	5x	5x
	Position 5	6x	6x
	Position 6	7x	7x
	Position 7	8x	8x
	Position 8	9x	9x
	Position 9	9x	9x
$t_{sd}$ = short delay time $I^2t$ (milliseconds) (LS, LSG)	Fixed	67 at10x	67 at10x
$t_{sd}$ = short delay time flat (milliseconds) (LSI, LSIG, ALSI, ALSIG) ①	Position 1	Inst	Inst
	Position 2	120	120
	Position 3	300	300
$I_g$ = ground fault pickup (amperes) (LSG, LSIG, ALSIG)	Position 1	160	240
	Position 2	240	360
	Position 3	320	480
	Position 4	480	720
	Position 5	640	960
	Position 6	800	1200
$t_g$ = ground fault delay time (milliseconds) (LSG, LSIG, ALSIG)	Position 1	Inst	Inst
	Position 2	120	120
	Position 3	300	300
Independently Adjustable Instantaneous ( $I_i$ ) setting (ALSI, ALSIG)	Yes	2.5x, 4x, 6x, 7x, 8x, 10x, 18x	2.5x, 4x, 6x, 7x, 8x, 10x, 12x
Maintenance Mode (remote) pickup ( $2.5 \times I_n$ ) (ALSI, ALSIG) ②	Fixed	2.5x	2.5x

**Notes**

① 50 ms for ALSI and ALSIG trip units.

② Maintenance Mode is enabled remotely using a 24 Vdc circuit.

**Dimensions and Weights**

Approximate Dimensions in Inches (mm)

**NG-Frame**

Number of Poles	Width	Height	Depth
3	8.25 (209.6)	16.00 (406.4)	5.50 (139.7)
4	11.13 (282.6)	16.00 (406.4)	5.50 (139.7)

**NG-Frame**

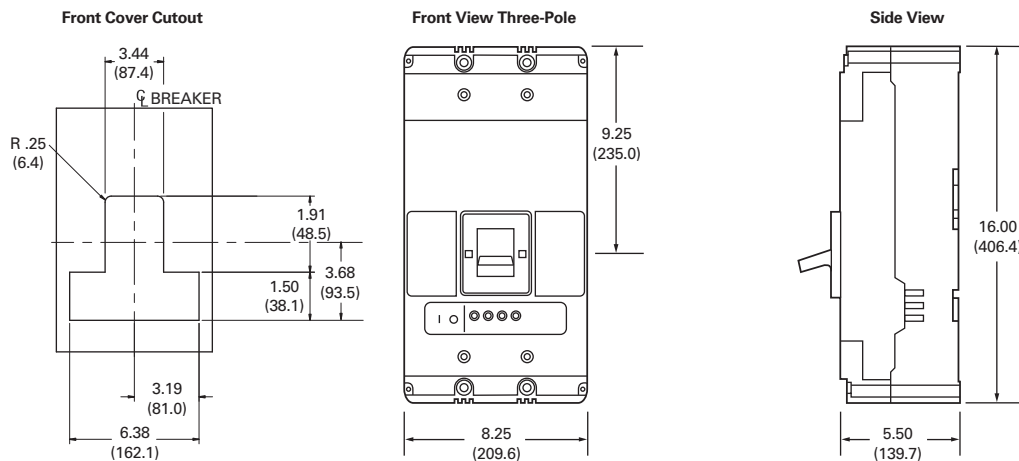

Approximate Shipping Weight in Lbs (kg)

**NG-Frame**

Breaker Type	Complete Breaker	
	Three-Pole	Four-Pole
NGS, NGH, NGC	45 (20.4)	58 (26.3)

#### RG-Frame (800–2500 Amperes)

2



#### Contents

<i>Description</i>	<i>Page</i>
EG-Frame (15–125 Amperes) . . . . .	<b>V4-T2-15</b>
JG-Frame (63–250 Amperes) . . . . .	<b>V4-T2-29</b>
LG-Frame (250–630 Amperes) . . . . .	<b>V4-T2-47</b>
NG-Frame (320–1200 Amperes) . . . . .	<b>V4-T2-65</b>
RG-Frame (800–2500 Amperes)	
Catalog Number Selection . . . . .	<b>V4-T2-75</b>
Product Selection . . . . .	<b>V4-T2-76</b>
Accessories . . . . .	<b>V4-T2-81</b>
Technical Data and Specifications . . . . .	<b>V4-T2-82</b>
Dimensions and Weights . . . . .	<b>V4-T2-84</b>
Motor Circuit Protectors (MCP) . . . . .	<b>V4-T2-85</b>
Motor Protector Circuit Breakers (MPCB) . . . . .	<b>V4-T2-89</b>
30 mA Ground Fault (Earth Leakage) Module . . . . .	<b>V4-T2-92</b>
Current Limiting Circuit Breaker Module . . . . .	<b>V4-T2-96</b>
High Instantaneous Circuit Breaker for	
Selective Coordination . . . . .	<b>V4-T2-101</b>
Special Features and Accessories . . . . .	<b>V4-T2-104</b>
Motor Operators . . . . .	<b>V4-T2-112</b>
Plug-In Blocks . . . . .	<b>V4-T2-114</b>
Drawout Cassette . . . . .	<b>V4-T2-115</b>

#### RG-Frame (800–2500 Amperes)

##### Product Description

- Eaton's RG-Frame circuit breakers are available as frame (which includes trip unit), rating plug and terminals
- All R-Frame circuit breakers are suitable for reverse feed use

### Catalog Number Selection

This information is presented only as an aid to understanding catalog numbers. It is not to be used to build catalog numbers for circuit breakers or trip units.

**70 kA at 415 Vac and 65 kA at 480 Vac**

### RG Circuit Breaker With 310+ Electronic Trip Unit

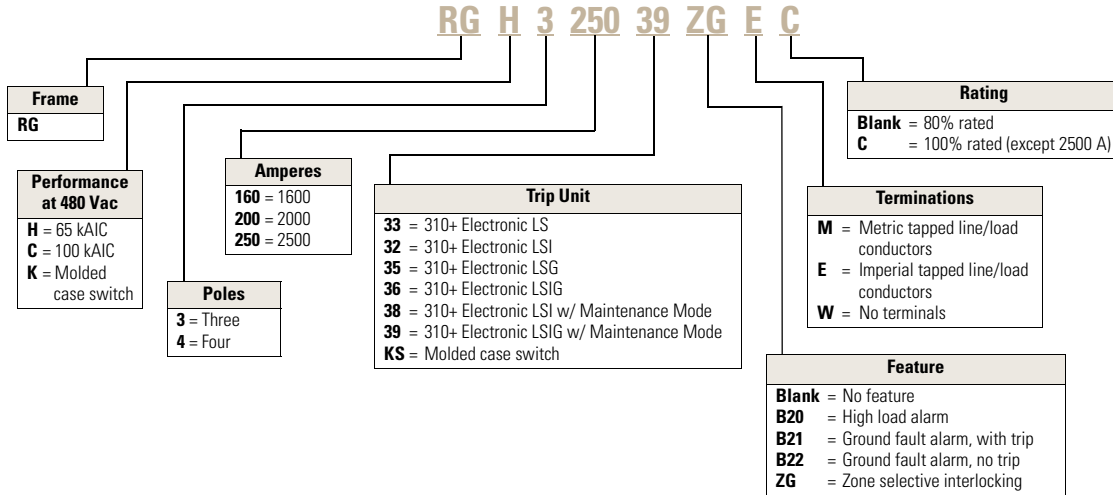

### RG 310+ Electronic Trip Unit

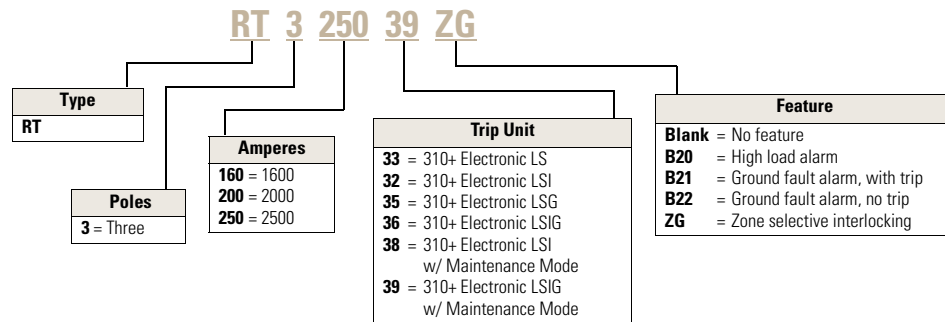

### RG Circuit Breaker with OPTIM 610 and 910 Electronic Trip Unit

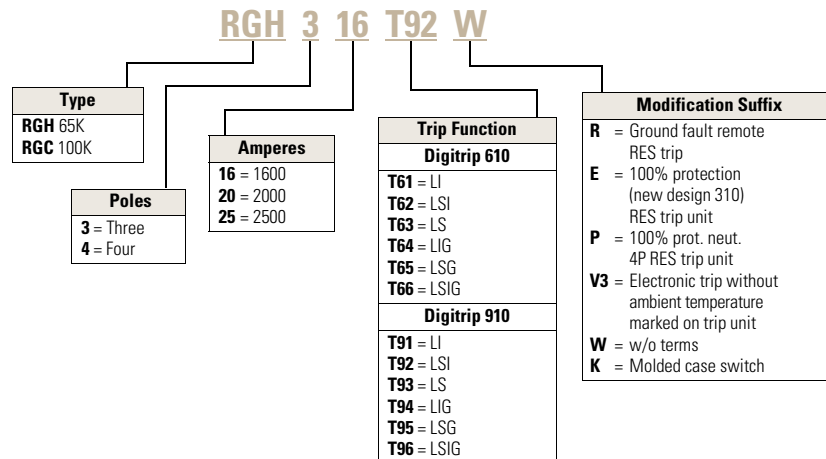

## Product Selection

## 70 kA at 415 Vac and 65 kA at 480 Vac

Type RGH with Digitrip 310+ High Interrupting Capacity— $U_e$  Maximum 690 Vac, 70 kA  $I_{cu}$  at 415 Vac

See 310+ adjustability specifications on Page V4-T2-83.

Maximum Continuous Ampere Rating at 40 °C ①	Number of Poles	Circuit Breaker Frame Including Digitrip RMS 310+ Electronic Trip Unit with Adjustable Rating Plugs—Catalog Number ②						Neutral CT for LSG and LSI ④
		LS	LSI	LSG ③	LSIG ③	ALSI	ALSIG	
1600 ①	3	RGH316033E	RGH316032E	RGH316035E	RGH316036E	RGH316038E	RGH316039E	RGFCT160A
2000	3	RGH320033E	RGH320032E	RGH320035E	RGH320036E	RGH320038E	RGH320039E	RGFCT200A
2500	3	RGH325033E	RGH325032E	RGH325035E	RGH325036E	RGH325038E	RGH325039E	RGFCT250A

## 100 kA at Both 415 Vac and 480 Vac

Type RGH with Digitrip 310+ High Interrupting Capacity— $U_e$  Maximum 690 Vac, 70 kA  $I_{cu}$  at 415 Vac

See 310+ adjustability specifications on Page V4-T2-83.

Maximum Continuous Ampere Rating at 40 °C ①	Number of Poles	Circuit Breaker Frame Including Digitrip RMS 310+ Electronic Trip Unit with Adjustable Rating Plugs—Catalog Number ②					
		LS	LSI	LSG ③⑤	LSIG ③⑤	ALSI	ALSIG ③⑤
1600 ①	4 ⑥	RGH416033E	RGH416032E	—	—	RGH416038E	—
2000	4 ⑥	RGH420033E	RGH420032E	—	—	RGH420038E	—
2500	4 ⑥	RGH425033E	RGH425032E	—	—	RGH425038E	—

## Notes

- ① For SCR application, use 2000 ampere frame.  
 ② Order terminals separately. Mounting hardware not included.  
 ③ Ground fault equipped trip units available with remote indicating panel. Add "R" to catalog number, for example, "RGH316035RW."  
 ④ Required for four-wire systems if neutral protection is desired. Sold separately.  
 ⑤ No neutral protection available on four-pole breakers with LSG or LSI trip units.  
 ⑥ Unprotected left pole neutral. Add "P" to catalog number for 100% protected left pole neutral, add "E" for 60% protected, for example, "RGH416033PW," "RGH416033EW."
- RG MCCBs have English threading on line and load conductors. Use suffix "M" for metric threading.

**100 kA at Both 415 Vac and 480 Vac****Type RGC with Digitrip 310+ Very High Interrupting Capacity— $U_e$  Maximum 690 Vac, 100 kA  $I_{cu}$  at 415 Vac**See 310+ adjustability specifications on **Page V4-T2-83**.

Maximum Continuous Ampere Rating at 40 °C ①	Number of Poles	Circuit Breaker Frame Including Digitrip RMS 310+ Electronic Trip Unit with Adjustable Rating Plugs—Catalog Number ②						Neutral CT for LSG and LSIG ④
		LS	LSI	LSG ③	LSIG ③	ALSI	ALSIG	
1600 ①	3	RGC316033E	RGC316032E	RGC316035E	RGC316036E	RGC316038E	RGC316039E	RGFCT160A
2000	3	RGC320033E	RGC320032E	RGC320035E	RGC320036E	RGC320038E	RGC320039E	RGFCT200A
2500	3	RGC325033E	RGC325032E	RGC325035E	RGC325036E	RGC325038E	RGC325039E	RGFCT250A

**Type RGC with Digitrip 310+ Very High Interrupting Capacity— $U_e$  Maximum 690 Vac, 100 kA  $I_{cu}$  at 415 Vac, continued**See 310+ adjustability specifications on **Page V4-T2-83**.

Maximum Continuous Ampere Rating at 40 °C ①	Number of Poles	Circuit Breaker Frame Including Digitrip RMS 310+ Electronic Trip Unit with Adjustable Rating Plugs—Catalog Number ②					
		LS	LSI	LSG ③⑤	LSIG ③⑤	ALSI	ALSIG ③⑤
1600 ①	4 ⑥	RGC416033E	RGC416032E	—	—	RGC416038E	—
2000	4 ⑥	RGC420033E	RGC420032E	—	—	RGC420038E	—
2500	4 ⑥	RGC425033E	RGC425032E	—	—	RGC425038E	—

**Molded Case Switches ⑦**

Ampere Rating	Number of Poles	Catalog Number
1600	3	RGK3160KSE
2000	3	RGK3200KSE
1600	4	RGK4160KSE
2000	4	RGK4200KSE

**Notes**

- ① For SCR application, use 2000 ampere frame.
- ② Order terminals separately. Mounting hardware not included.
- ③ Ground fault equipped trip units available with remote indicating panel. Add "R" to catalog number, for example, "RGH316035RW."
- ④ Required for four-wire systems if neutral protection is desired. Sold separately.
- ⑤ No neutral protection available on four-pole breakers with LSG or LSIG trip units.
- ⑥ Unprotected left pole neutral. Add "P" to catalog number for 100% protected left pole neutral, add "E" for 60% protected, for example, "RGH416033PW," "RGH416033EW."
- ⑦ Molded case switch will trip above 17,500 amperes.

RG MCCBs have English threading on line and load conductors. Use suffix "M" for metric threading.

# 2.2

## Molded Case Circuit Breakers

### Series G

2

#### Type RG with Digitrip 610 and 910

Circuit Breaker Frame Including Digitrip RMS 610 and 910 Electronic Trip Unit with Rating Plugs  
Order as Individual Component—Catalog Number ①

Maximum Continuous Ampere Rating at 40 °C	Number of Poles	Circuit Breaker Frame Including Digitrip RMS 610 and 910 Electronic Trip Unit with Rating Plugs Order as Individual Component—Catalog Number ①						Digitrip RMS Interchangeable Rating Plug (Order as Individual Component)	Fixed Rating Plug
		LI	LS	LSI	LIG	LSG	LSIG		
<b>Long Delay Pickup</b>		0.5–1.0 x I <sub>n</sub>	0.5–1.0 <sub>n</sub>	0.5–1.0 x I <sub>n</sub>	0.5–1.0 x I <sub>n</sub>	0.5–1.0 x I <sub>n</sub>	0.5–1.0 x I <sub>n</sub>		
<b>Long Delay Time</b>		2–24 Seconds	2–24 Seconds	2–24 Seconds	2–24 Seconds	2–24 Seconds	2–24 Seconds		
<b>Short Time Range</b>		2–6 x I <sub>r</sub>	2–6 x I <sub>r</sub>	2–6 x I <sub>r</sub>	2–6 x I <sub>r</sub>	2–6 x I <sub>r</sub>	2–6 x I <sub>r</sub>		
<b>Short Time Delay</b>		—	100–500 ms	100–500 ms	—	100–500 ms	100–500 ms		
<b>Instantaneous</b>		2–6 x M1 and M2	—	2–6 x M1 and M2	2–6 x M1 and M2	—	2–6 x M1 and M2		
<b>Ground Fault Pickup</b>		—	—	—	0.25–1.0 x I <sub>n</sub> ②	0.25–1.0 x I <sub>n</sub> ②	0.25–1.0 x I <sub>n</sub> ②	<b>Ampere Rating</b>	
<b>Ground Fault Delay</b>		—	—	—	100–500 ms	100–500 ms	100–500 ms	<b>Catalog Number</b>	

#### Type RGH with Digitrip 610 High Interrupting Capacity—U<sub>e</sub> Max. 690 Vac, 70 kA I<sub>cu</sub> at 415 Vac

1600	3	RGH316T61WP44	RGH316T63WP44	RGH316T62WP44	RGH316T64WP44	RGH316T65WP44	RGH316T66WP44	800	RP6R16A080
								1000	RP6R16A100
								1200	RP6R16A120
								1250	RP6R16A125
								1600	RP6R16A160
<b>Includes 1600 A rating plug</b>									
2000	3	RGH320T61WP49	RGH320T63WP49	RGH320T62WP49	RGH320T64WP49	RGH320T65WP49	RGH320T66WP49	1000	RP6R20A100
								1200	RP6R20A120
								1250	RP6R20A125
								1600	RP6R20A160
								2000	RP6R20A200
<b>Includes 2000 A rating plug</b>									
2500	3	RGH325T61WP53	RGH325T63WP53	RGH325T62WP53	RGH325T64WP53	RGH325T65WP53	RGH325T66WP53	1600	RP6R25A160
								2000	RP6R25A200
								2500	RP6R25A250

#### Type RGC with Digitrip 610 Very High Interrupting Capacity—U<sub>e</sub> Max. 690 Vac, 100 kA I<sub>cu</sub> at 415 Vac

1600	3	RGC316T61WP44	RGC316T63WP44	RGC316T62WP44	RGC316T64WP44	RGC316T65WP44	RGC316T66WP44	800	RP6R16A080
								1000	RP6R16A100
								1200	RP6R16A120
								1250	RP6R16A125
								1600	RP6R16A160
<b>Includes 1600 A rating plug</b>									
2000	3	RGC320T61WP49	RGC320T63WP49	RGC320T62WP49	RGC320T64WP49	RGC320T65WP49	RGC320T66WP49	1000	RP6R20A100
								1200	RP6R20A120
								1250	RP6R20A125
								1600	RP6R20A160
								2000	RP6R20A200
<b>Includes 2000 A rating plug</b>									
2500	3	RGC325T61WP53	RGC325T63WP53	RGC325T62WP53	RGC325T64WP53	RGC325T65WP53	RGC325T66WP53	1600	RP6R25A160
								2000	RP6R25A200
								2500	RP6R25A250

#### Notes

① Order terminals separately. Mounting hardware not included.

② Not to exceed 1200 ampere ground fault pickup.

RG MCCBs have metric threading on line and load conductors. Use RD MCCBs if imperial threading is required.

Type RG with Digitrip 610 and 910, continued

Circuit Breaker Frame Including Digitrip RMS 610 and 910 Electronic Trip Unit with Rating Plugs Order as Individual Component—Catalog Number ①										
Maximum Continuous Ampere Rating at 40 °C	Number of Poles	L – Adjustable Long Delay Pickup ( $I_L$ ) with Adjustable Long Delay Time S – Adjustable Short Delay Pickup with Adjustable Short Delay Time ( $I^2t$ or Flat Response) I – Adjustable Instantaneous Pickup G – Adjustable Ground Fault Pickup with Adjustable Ground Fault Time Delay ( $I^2t$ or Flat Response)						Digitrip RMS Interchangeable Rating Plug (Order as Individual Component)	Fixed Rating Plug	
		LI	LS	LSI	LIG	LSG	LSIG			
Long Delay Pickup		0.5–1.0 x $I_n$	0.5–1.0 $_n$	0.5–1.0 x $I_n$	0.5–1.0 x $I_n$	0.5–1.0 x $I_n$	0.5–1.0 x $I_n$			
Long Delay Time		2–24 Seconds	2–24 Seconds	2–24 Seconds	2–24 Seconds	2–24 Seconds	2–24 Seconds			
Short Time Range		2–6 x $I_r$	2–6 x $I_r$	2–6 x $I_r$	2–6 x $I_r$	2–6 x $I_r$	2–6 x $I_r$			
Short Time Delay		—	100–500 ms	100–500 ms	—	100–500 ms	100–500 ms			
Instantaneous		2–6 x M1 and M2	—	2–6 x M1 and M2	2–6 x M1 and M2	—	2–6 x M1 and M2			
Ground Fault Pickup		—	—	—	0.25–1.0 x $I_n$ ②	0.25–1.0 x $I_n$ ②	0.25–1.0 x $I_n$ ②			
Ground Fault Delay		—	—	—	100–500 ms	100–500 ms	100–500 ms	Ampere Rating	Catalog Number	
<b>Type RGH with Digitrip 910 High Interrupting Capacity—<math>U_e</math> Max. 690 Vac, 70 kA <math>I_{cu}</math> at 415 Vac</b>										
1600	3	RGH316T91WP44	RGH316T93WP44	RGH316T92WP44	RGH316T94WP44	RGH316T95WP44	RGH316T96WP44	800	RP6R16A080	
								1000	RP6R16A100	
								1200	RP6R16A120	
								1250	RP6R16A125	
		Includes 1600 A rating plug							1600	RP6R16A160
2000	3	RGH320T91WP49	RGH320T93WP49	RGH320T92WP49	RGH320T94WP49	RGH320T95WP49	RGH320T96WP49	1000	RP6R20A100	
								1200	RP6R20A120	
								1250	RP6R20A125	
								1600	RP6R20A160	
		Includes 2000 A rating plug							2000	RP6R20A200
2500	3	RGH325T91WP53	RGH325T93WP53	RGH325T92WP53	RGH325T94WP53	RGH325T95WP53	RGH325T96WP53	1600	RP6R25A160	
								2000	RP6R25A200	
								2500	RP6R25A250	
		Includes 2500 A rating plug								
<b>Type RGC with Digitrip 910 Very High Interrupting Capacity—<math>U_e</math> Max. 690 Vac, 100 kA <math>I_{cu}</math> at 415 Vac</b>										
1600	3	RGC316T91WP44	RGC316T93WP44	RGC316T92WP44	RGC316T94WP44	RGC316T95WP44	RGC316T96WP44	800	RP6R16A080	
								1000	RP6R16A100	
								1200	RP6R16A120	
								1250	RP6R16A125	
		Includes 1600 A rating plug							1600	RP6R16A160
2000	3	RGC320T91WP49	RGC320T93WP49	RGC320T92WP49	RGC320T94WP49	RGC320T95WP49	RGC320T96WP49	1000	RP6R20A100	
								1200	RP6R20A120	
								1250	RP6R20A125	
								1600	RP6R20A160	
		Includes 2000 A rating plug							2000	RP6R20A200
2500	3	RGC325T91WP53	RGC325T93WP53	RGC325T92WP53	RGC325T94WP53	RGC325T95WP53	RGC325T96WP53	1600	RP6R25A160	
								2000	RP6R25A200	
								2500	RP6R25A250	
		Includes 2500 A rating plug								

Notes

① Order terminals separately. Mounting hardware not included.

② Not to exceed 1200 ampere ground fault pickup.

RG MCCBs have metric threading on line and load conductors. Use RD MCCBs if imperial threading is required.

### Accessories Selection Guide and Ordering Information

#### Line and Load Terminals

R-Frame circuit breakers use Cu/Al terminals as standard and copper only terminals as an option. Specify if factory installation is required. Must have terminals for 100% rated and or freeze testing requirements.

#### Line and Load Terminals

Maximum Breaker Amperes	Terminal Body Material	Wire Type	Hardware	AWG/kcmil Wire Range/ Number of Conductors	Metric Wire Range mm <sup>2</sup>	Catalog Number
<b>Wire Terminals</b>						
1600	Aluminum	Cu/Al	Metric	500–1000 (4)	300–500	<b>TA1600RDM</b> ①
1600	Copper	Cu	Metric	1–600 (4)	50–300	<b>T1600RDM</b> ①
2000	Aluminum	Cu/Al	Metric	2–600 (6)	35–300	<b>TA2000RDM</b> ②
<b>Rear Connectors</b>						
2000	Copper	—	Metric	—	—	<b>B2016RDM</b> ①
2000	Copper	—	Metric	—	—	<b>B2016RDLM</b> ①
2500	Copper	—	Metric	—	—	<b>B2500RDM</b> ①

#### RG Rear Connector Exploded View

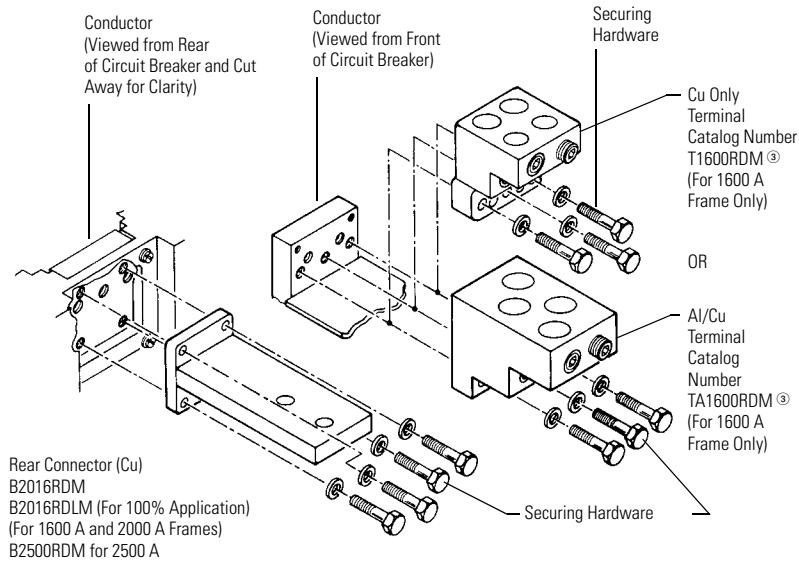

#### TA2000RD Wire Terminal

**Note:** Order one TA2000RDM kit per three poles. Catalog number includes bus connection, terminals and hardware for either line side or load side of three-pole breaker.

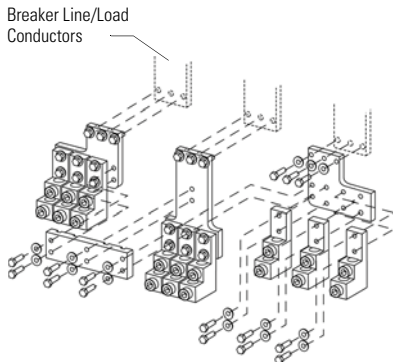

#### Base Mounting Hardware

Supplied by customer.

#### Handle Extension

Included with breaker. Additional handle extensions are available.

#### Handle Extension

Description	Catalog Number
Single handle extension	<b>HEX6</b>

#### Wire Seal

The wire seal can be used to secure the cover on the trip unit to prevent adjustments after settings are confirmed.

#### Wire Seal

Description	Catalog Number
Wire seal	<b>5108A03H01</b>

#### Notes

- ① Order one per pole—single terminals individually packed.
- ② Order one TA2000RD kit per three poles. Catalog number includes bus connection, terminals and hardware for either line side or load side of three-pole breaker.
- ③ For use with 2500 A Frame. Do not order separately unless for replacement purposes. Included in breaker carton when 2500 A frame is ordered.

RG MCCBs have metric threading on line and load conductors. Use RD MCCBs if imperial threading is required.

## Accessories

### Allowable Accessory Combinations

Different combinations of accessories can be supplied, depending on the types of accessories and the number of poles in the circuit breaker.

### RG-Frame Accessories

Description	Reference Page	Three-Pole			Four-Pole			
		Left	Center	Right	Left	Center	Right	Neutral
<b>Internal Accessories (Only One Internal Accessory Per Pole)</b>								
Alarm lockout (Make/Break)	V4-T2-109			■			■	
Auxiliary switch (1A, 1B)	V4-T2-109			■			■	
Auxiliary switch (2A, 2B)	V4-T2-109			■			■	
Auxiliary switch and alarm switch combination	V4-T2-109			■			■	
Shunt trip—standard	V4-T2-109			●			●	
Undervoltage release mechanism	V4-T2-110			●			●	
<b>External Accessories</b>								
Base mounting hardware	V4-T2-80	●	●	●	●	●	●	●
Padlockable handle lock hasp	V4-T2-107	□		□	□		□	
Key interlock kit	V4-T2-107	□		□	□		□	
Electrical operator	V4-T2-107	●	●	●	●	●	●	●
Handle mechanisms	V4-T2-420	●	●	●	●	●	●	●
Handle extension	V4-T2-80	●	●	●	●	●	●	●
Digitrip 310+ test kit	V4-T2-106	●	●	●	●	●	●	●
<b>Modifications (Refer to Eaton)</b>								
Moisture fungus treatment	V4-T2-105	●	●	●	●	●	●	●
Freeze-tested circuit breakers	—	●	●	●	●	●	●	●
Marine/naval application, UL 489 Supplement SA and SB	①	●	●	●	●	●	●	●

### Legend

- Applicable in indicated pole position
- May be mounted on left or right pole—not both
- Accessory available/modification available

### 310+ Electronic Trip Unit Accessories

Description	Catalog Number
Electronic portable test kit	MTST230V
Trip unit tamper protection wire seal	5108A03H01
External neutral sensor (2500 A) ②	RGFCT250A
External neutral sensor (2000 A) ②	RGFCT200A
External neutral sensor (1600 A) ②	RGFCT160A
Breaker-mount cause-of-trip indication ③	—
Breaker-mount ammeter module	DIGIVIEW
Remote-mount ammeter module	DIGIEWR06

### Notes

- ① Contact Eaton.
- ② Required for four-wire systems if neutral protection is desired. Sold separately.
- ③ Cause-of-trip indication LEDs integrated in RG 310+ trip units.

## Technical Data and Specifications

2

### UL 489/CSA Interrupting Capacity Ratings <sup>①</sup>

Circuit Breaker Type	Number of Poles	Interrupting Capacity (kA Symmetrical Amperes)			
		Volts AC (50/60 Hz)			
		240	277	480	600
RGH	3, 4	125	—	65	50
RGC	3, 4	200	—	100	65

### IEC 947-2 Interrupting Capacity Ratings <sup>①</sup>

Circuit Breaker Type	Number of Poles	Interrupting Capacity (kA Symmetrical Amperes)		
		Volts AC (50/60 Hz)		
		240	415	690
RGH	3, 4			
$I_{cu}$		135	70	25
$I_{cs}$		100	50	13
RGC	3, 4			
$I_{cu}$		200	100	35
$I_{cs}$		100	50	18

### RG 310+ Specifications

Description	Specification
Trip Unit Type	Digitrip RMS 310+
<b>Breaker Type</b>	
Frame designation	RG
Frames available	1600 A, 2000 A, 2500 A
Continuous current range (A)	800–2500 A
Ground fault pickup (A)	200–1200 A
Interrupting capacities at 480 Vac (kAIC)	65, 100
100% rated	Yes
<b>Protection</b>	
Ordering options	LS, LSI, LSG, LSIG, ALSI, ALSIG
Arcflash reduction maintenance system (or maintenance mode)	Yes
Interchangeable trip unit	Yes
High load alarm (suffix B20) <sup>②</sup>	Yes
Ground fault alarm with trip (suffix B21) <sup>②</sup>	Yes
Ground fault alarm, no trip (suffix B22) <sup>②</sup>	Yes
Zone selective interlocking (suffix ZG)	LSI, LSIG, ALSI, ALSIG
Cause of trip indication	Yes
Thru-cover accessories	No

#### Notes

<sup>①</sup> Utilization Category A circuit breakers.

<sup>②</sup> B2x suffixes cannot be combined with B2x suffixes.

See **Page V4-T2-74** for trip unit specifications.

## RG 310+ Adjustability Specifications

310+ Settings		RG Frame		
		1600 A	2000 A	2500 A
$I_r$ = continuous current or long delay pickup (amperes) (All 310+)	$I_r$			
	A	800	1000	1600
	B	900	1200	1700
	C	1000	1400	1800
	D	1100	1600	2000
	E	1200	1700	2100
	F	1400	1800	2200
	G	1500	1900	2400
	H (= $I_n$ )	1600	2000	2500
$t_r$ = long delay time (seconds) (All 310+)	Position 1	2	2	2
	Position 2	4	4	4
	Position 3	7	7	7
	Position 4	10	10	10
	Position 5	12	12	12
	Position 6	15	15	15
	Position 7	20	20	20
	Position 8	24	24	24
$I_{sd}$ ( $\times I_r$ ) = short delay pickup (All 310+)	Position 1	2x	2x	2x
	Position 2	3x	3x	2x
	Position 3	4x	4x	2x
	Position 4	5x	5x	3x
	Position 5	6x	6x	4x
	Position 6	7x	7x	5x
	Position 7	8x	8x	6x
	Position 8	8x	8x	6x
	Position 9	9x	9x	6x
$t_{sd}$ = short delay time $I^2t$ (milliseconds) (LS, LSG)	Fixed	67 at10x	67 at10x	67 at10x
$t_{sd}$ = short delay time flat (milliseconds) (LSI, LSIG, ALSI, ALSIG) ①	Position 1	Inst	Inst	Inst
	Position 2	120	120	120
	Position 3	300	300	300
$I_g$ = ground fault pickup (amperes) (LSG, LSIG, ALSIG)	Position 1	200	200	200
	Position 2	400	400	400
	Position 3	600	600	600
	Position 4	800	800	800
	Position 5	1000	1000	1000
	Position 6	1200	1200	1200
$t_g$ = ground fault delay time (milliseconds) (LSG, LSIG, ALSIG)	Position 1	Inst	Inst	Inst
	Position 2	120	120	120
	Position 3	300	300	300
Independently Adjustable Instantaneous ( $I_i$ ) setting (ALSI, ALSIG)	Yes	2.5x, 4x, 6x, 7x, 8x, 11x	2.5x, 4x, 6x, 7x, 8x, 9x	2.5x, 4x, 6x, 7x
Maintenance Mode (remote) pickup ( $2.5 \times I_n$ ) (ALSI, ALSIG) ②	Fixed	2.5x	2.5x	2.5x

**Notes**

- ① 50 ms for ALSI and ALSIG trip units.
- ② Maintenance Mode is enabled remotely using a 24 Vdc circuit.

# 2.2

## Molded Case Circuit Breakers

### Series G

#### Dimensions and Weights

Approximate Dimensions in Inches (mm)

2

#### RG-Frame

Number of Poles	Width	Height	Depth
3	15.50 (393.7)	16.00 (406.4)	9.75 (247.7)
4	20.00 (508.0)	16.00 (406.4)	9.75 (247.7)

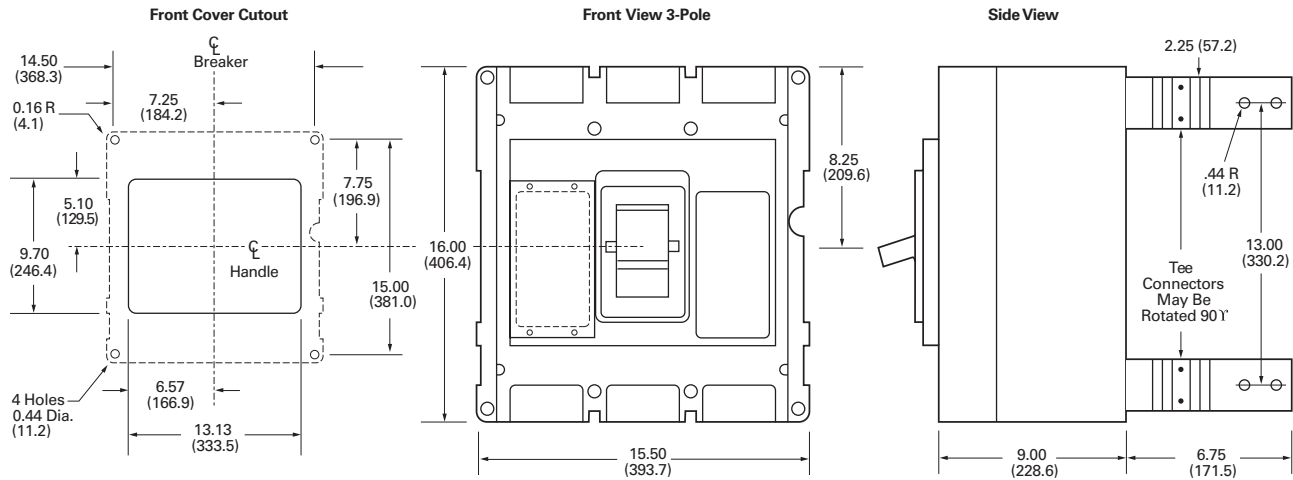

Approximate Shipping Weight in Lbs (kg)

#### RG-Frame

Breaker Type	Complete Breaker	
	Number of Poles Three-Pole	Four-Pole
<b>1600 Amperes</b>		
RGH, RGC	102 (46.3)	135 (61.2)
<b>2000 Amperes</b>		
RGH, RGC	102 (46.3)	135 (61.2)
<b>2500 Amperes</b>		
RGH, RGC	135 (61.2)	182 (82.6)

Motor Circuit 480 Vac, Protectors



## Contents

<i>Description</i>	<i>Page</i>
EG-Frame (15–125 Amperes) . . . . .	<b>V4-T2-15</b>
JG-Frame (63–250 Amperes) . . . . .	<b>V4-T2-29</b>
LG-Frame (250–630 Amperes) . . . . .	<b>V4-T2-47</b>
NG-Frame (320–1200 Amperes) . . . . .	<b>V4-T2-65</b>
RG-Frame (800–2500 Amperes) . . . . .	<b>V4-T2-74</b>
Motor Circuit Protectors (MCP) Product Selection Guide and Ordering Information . . . . .	<b>V4-T2-86</b>
Motor Protector Circuit Breakers (MPCB). . . . .	<b>V4-T2-89</b>
30 mA Ground Fault (Earth Leakage) Module. . . . .	<b>V4-T2-92</b>
Current Limiting Circuit Breaker Module . . . . .	<b>V4-T2-96</b>
High Instantaneous Circuit Breaker for Selective Coordination . . . . .	<b>V4-T2-101</b>
Special Features and Accessories. . . . .	<b>V4-T2-104</b>
Motor Operators . . . . .	<b>V4-T2-112</b>
Plug-In Blocks . . . . .	<b>V4-T2-114</b>
Drawout Cassette . . . . .	<b>V4-T2-115</b>

## Motor Circuit Protectors (MCP)

## Product Selection Guide and Ordering Information

2

EG-Frame—480 Vac, 600Y/347 Vac Maximum <sup>①</sup>

Continuous Amperes	Cam Setting	Motor Full Load Current Amperes <sup>②</sup>	MCP Trip Setting <sup>③</sup>	MCP Catalog Number
3	A	0.69–0.91	9	HMCPE003A0C
	B	1.1–1.3	15	
	C	1.6–1.7	21	
	D	2.0–2.2	27	
	E	2.3–2.5	30	
	F	2.6–2.8	33	
7	A	1.5–2.0	21	HMCPE007C0C
	B	2.6–3.1	35	
	C	3.7–3.9	49	
	D	4.8–5.2	63	
	E	5.3–5.7	70	
	F	5.8–6.1	77	
15	A	3.4–4.5	45	HMCPE015E0C
	B	5.7–6.8	75	
	C	8.0–9.1	105	
	D	10.4–11.4	135	
	E	11.5–12.6	150	
	F	12.7–13.0	165	
30	A	3.9–9.1	90	HMCPE030H1C
	B	11.5–13.7	150	
	C	16.1–18.3	210	
	D	20.7–22.9	270	
	E	23.0–25.2	300	
	F	25.3–26.1	330	

**Notes**

- ① UL listed for use with Eaton Motor Starters.
- ② Motor FLA ranges are typical. The corresponding trip setting is at 13 times the minimum FLA value shown. Where a 13 times setting is required for an intermediate FLA value, alternate cam settings and/or MCP ratings should be used.
- ③ For DC applications, actual trip levels are approximately 40% higher than values shown.

EG-Frame—480 Vac, 600Y/347 Vac Maximum, continued <sup>①</sup>

Continuous Amperes	Cam Setting	Motor Full Load Current Amperes <sup>②</sup>	MCP Trip Setting <sup>③</sup>	MCP Catalog Number
50	A	11.5–15.2	150	HMCPE050K2C
	B	19.2–22.9	250	
	C	26.9–30.6	350	
	D	34.6–38.3	450	
	E	38.4–42.1	500	
	F	42.2–43.5	550	
70	A	16.1–30.6	210	HMCPE070M2C
	B	26.9–32.2	350	
	C	37.6–42.9	490	
	D	48.4–53.7	630	
	E	53.8–59.1	700	
	F	59.2–60.9	770	
100	A	23.0–30.6	300	HMCPE100R3C
	B	38.4–46.0	500	
	C	53.8–61.4	700	
	D	69.2–76.8	900	
	E	76.9–84.5	1000	
	F	84.6–87.0	1100	
100	A	38.4–46.0	500	HMCPE100T3C
	B	57.6–65.2	750	
	C	76.9–84.5	1000	
	D	④	1250	
	E	④	1375	
	F	④	1500	

JG-Frame—600 Vac Maximum, 250 Vdc Maximum <sup>①</sup>

Continuous Amperes	MCP Trip Range (Amperes)	MCP Catalog Number
250	500–1000	HMCPJ250D5L
	625–1250	HMCPJ250F5L
	750–1500	HMCPJ250G5L
	875–1750	HMCPJ250J5L
	1000–2000	HMCPJ250K5L
	1125–2250	HMCPJ250L5L
	1250–2500	HMCPJ250W5L

**Notes**

- <sup>①</sup> UL listed for use with Eaton Motor Starters.
- <sup>②</sup> Motor FLA ranges are typical. The corresponding trip setting is at 13 times the minimum FLA value shown. Where a 13 times setting is required for an intermediate FLA value, alternate cam settings and/or MCP ratings should be used.
- <sup>③</sup> For DC applications, actual trip levels are approximately 40% higher than values shown.
- <sup>④</sup> Settings above 10 x  $I_n$  are for special applications. Where the ampere rating of the disconnecting means cannot be less than 115% of the motor full load ampere rating.

LG-Frame—600 Vac Maximum, 250 Vdc Maximum <sup>①</sup>

2

Continuous Amperes	MCP Trip Range (Amperes)	MCP Catalog Number
600	1250–2500	HMCPL600L6G
	1500–3000	HMCPL600N6G
	1750–3500	HMCPL600R6G
	2000–4000	HMCPL600X6G
	2250–4500	HMCPL600Y6G
	2500–5000	HMCPL600P6G
	3000–6000	HMCPL600M6G

**Notes**

<sup>①</sup> UL listed for use with Eaton Motor Starters.

800 and 1200 ampere, 600 Vac maximum motor circuit protectors are available as Series C HMCP product.

## Series G Motor Protector Circuit Breakers (MPCB)



## Contents

<b>Description</b>	<b>Page</b>
EG-Frame (15–125 Amperes) . . . . .	<b>V4-T2-15</b>
JG-Frame (63–250 Amperes) . . . . .	<b>V4-T2-29</b>
LG-Frame (250–630 Amperes) . . . . .	<b>V4-T2-47</b>
NG-Frame (320–1200 Amperes) . . . . .	<b>V4-T2-65</b>
RG-Frame (800–2500 Amperes) . . . . .	<b>V4-T2-74</b>
Motor Circuit Protectors (MCP) . . . . .	<b>V4-T2-85</b>
Motor Protector Circuit Breakers (MPCB)	
Product Selection . . . . .	<b>V4-T2-90</b>
Technical Data and Specifications . . . . .	<b>V4-T2-91</b>
30 mA Ground Fault (Earth Leakage) Module . . . . .	<b>V4-T2-92</b>
Current Limiting Circuit Breaker Module . . . . .	<b>V4-T2-96</b>
High Instantaneous Circuit Breaker for	
Selective Coordination . . . . .	<b>V4-T2-101</b>
Special Features and Accessories . . . . .	<b>V4-T2-104</b>
Motor Operators . . . . .	<b>V4-T2-112</b>
Plug-In Blocks . . . . .	<b>V4-T2-114</b>
Drawout Cassette . . . . .	<b>V4-T2-115</b>

## Motor Protector Circuit Breakers (MPCB)

## Product Description

- Eliminates need for separate overload relay

## Application Description

- Can be used with contactor to eliminate need for overload relay and still create manual motor control
- Meets requirement for motor branch protection, including:
  - Disconnecting means
  - Branch circuit short circuit protection
  - Overload protection

## Features and Benefits

- Phase unbalance protection
- Phase loss protection
- Hot trip/cold trip
- High load alarm
- Pre-detection trip relay option
- Class 10, 15, 20, 30 protection

## Standards and Certifications

- IEC 60947-2
- UL 489 100% rated
- UL 508
- CSA C22.2



## Product Selection

2

## JGMP Catalog Numbers

Continuous Amperes	35 kAIC Catalog Number	65 kAIC Catalog Number
50	JGMPS050G	JGMPH050G
100	JGMPS100G	JGMPH100G
160	JGMPS160G	JGMPH160G
250	JGMPS250G	JGMPH250G

## JGMP FLA Ie Dial Setting

Continuous Amperes	A	B	C	D	E	F	G	H
50	20	20	25	30	32	40	45	50
100	40	45	50	63	70	80	90	100
160	63	80	90	100	110	125	150	160
250	100	125	150	160	175	200	225	250

## LGMP Catalog Numbers

Continuous Amperes	50 kAIC Catalog Number	65 kAIC Catalog Number
250	LGMP250G	LGMPH250G
400	LGMP400G	LGMPH400G
600	LGMP600G	LGMPH600G
630 ①	LGMP630G	LGMPH630G

## LGMP FLA Ie Dial Setting

Continuous Amperes	A	B	C	D	E	F	G	H
250	100	125	150	160	175	200	225	250
400	160	200	225	250	300	315	350	400
600	250	300	315	350	400	450	500	600
630 ①	250	300	315	350	400	500	600	630

**Notes**

① 630 amperes is not a UL listed rating. 600 amperes is the maximum UL or CSA for LG breaker.

For pre-trip alarm option, order Style Number 5721B31G02.

For additional breaker solutions, see **Page V4-T2-267**.

## Technical Data and Specifications

### JGMPS and JGMPH Rating and Ampere Range

Breaker Capacity (kA rms) AC 50–60 Hz			Maximum Rated Current—250 A	
			Breaker Type	
			JGMPS	JGMPH
IEC 60947-2	220–240 Vac	I cu	85	100
		I cs	85	100
	380–415 Vac	I cu	40	70
		I cs	40	70
	660–690 Vac	I cu	12	14
		I cs	6	7
NEMA UL 489	240 Vac		85	100
	480 Vac		35	65
	600 Vac		25	35
Number of poles			3	3
Ampere range			50–250	50–250

### LGMP5 and LGMPH Rating and Ampere Range

Breaker Capacity (kA rms) AC 50–60 Hz			Maximum Rated Current—630 A <sup>①</sup>	
			Breaker Type	
			LGMP5	LGMPH
IEC 60947-2	220–240 Vac	I cu	85	100
		I cs	85	100
	380–415 Vac	I cu	50	70
		I cs	50	53
	660–690 Vac	I cu	20	25
		I cs	10	13
NEMA UL 489	240 Vac		85	100
	480 Vac		50	65
	600 Vac		25	35
Number of poles			3	3
Ampere range			250–630 <sup>①</sup>	250–630 <sup>①</sup>

#### Notes

<sup>①</sup> 630 amperes is not a UL listed rating. 600 amperes is the maximum UL or CSA for LG breaker.

For pre-trip alarm option, order Style Number 5721B31G02.

#### 30 mA Ground Fault (Earth Leakage) Modules



**Clockwise from Left:  
JG, LG, EG MCCBs Shown with  
Ground Fault (Earth Leakage) Module**

### 30 mA Ground Fault (Earth Leakage) Module

#### Product Description

Eaton offers three- and four-pole 30 mA ground fault (earth leakage) protection modules for Series G E-, J- and L-frame molded case circuit breakers (MCCBs). Separate UL listed and IEC rated devices are available for each frame.

The modules are bottom mounted and are available for each frame circuits up to:

- EG: 125 amperes
- JG: 150 (UL), 160 (IEC) or 250 amperes
- LG: 400, 600 (UL) or 630 (IEC) amperes

The module is completely self contained, including a current sensor, relay and power supply inside the device. Current pickup settings are selectable from 0.03 to 10 amperes for all devices, except for the UL listed module, for which settings are selectable from 0.03 to 30 amperes. Time delays are also selectable from Instantaneous to 1.0 second for pickup settings of 0.10 amperes and above. The current pickup setting of 0.03 amperes defaults to an Instantaneous time setting regardless of the time dial's position.

Two alarm contacts are included with each device, which can be wired externally for remote indication. Both of these are also indicated by an LED on the front of the device:

1. 50% pre-trip: alarms when the earth leakage current reaches 50% of the set pickup setting value.
2. 100% after trip: alarms when the breaker reaches the set pickup setting value and the breaker trips.

### Contents

Description	Page
EG-Frame (15–125 Amperes)	V4-T2-15
JG-Frame (63–250 Amperes)	V4-T2-29
LG-Frame (250–630 Amperes)	V4-T2-47
NG-Frame (320–1200 Amperes)	V4-T2-65
RG-Frame (800–2500 Amperes)	V4-T2-74
Motor Circuit Protectors (MCP)	V4-T2-85
Motor Protector Circuit Breakers (MPCB)	V4-T2-89
30 mA Ground Fault (Earth Leakage) Module	
Product Selection	V4-T2-93
Dimensions	V4-T2-94
Current Limiting Circuit Breaker Module	V4-T2-96
High Instantaneous Circuit Breaker for	
Selective Coordination	V4-T2-101
Special Features and Accessories	V4-T2-104
Motor Operators	V4-T2-112
Plug-In Blocks	V4-T2-114
Drawout Cassette	V4-T2-115

#### UL-Rated LG-Frame Earth Leakage Module Faceplate

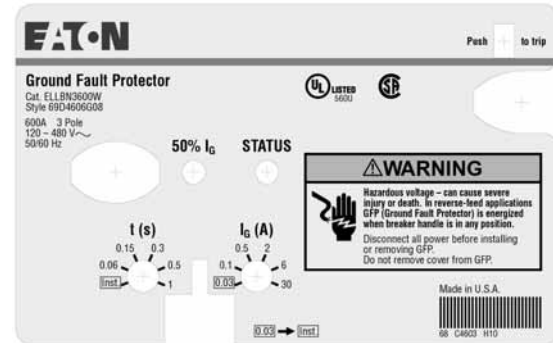

#### IEC-Rated LG-Frame Earth Leakage Module Faceplate

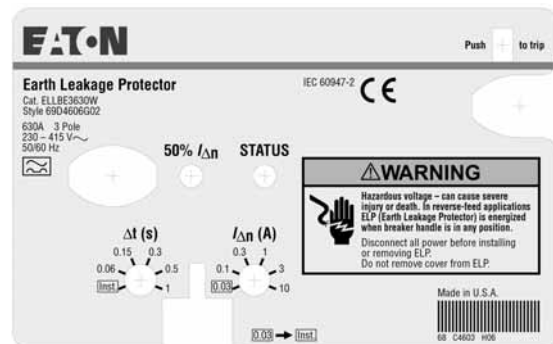

## Product Selection

## EG-Frame

**EG-Frame Ground Fault Modules, UL-Rated (Bottom Mounted, 120–480 Vac, 50/60 Hz) ①**

Ampere Rating	Number of Poles	Catalog Number
125	3	ELEBN3125G
125	4	ELEBN4125G

**EG-Frame Earth Leakage Modules, IEC-Rated (Bottom Mounted, 230–415 Vac, 50/60 Hz)**

Ampere Rating	Number of Poles	Catalog Number
125	3	ELEBE3125G
125	4	ELEBE4125G

## JG-Frame

**JG-Frame Ground Fault Modules, UL-Rated (Bottom Mounted, 120–480 Vac, 50/60 Hz)**

Ampere Rating	Number of Poles	Catalog Number
150	3	ELJBN3150W
150	4	ELJBN4150W
250	3	ELJBN3250W
250	4	ELJBN4250W

**JG-Frame Earth Leakage Modules, IEC-Rated (Bottom Mounted, 230–415 Vac, 50/60 Hz)**

Ampere Rating	Number of Poles	Catalog Number
160	3	ELJBE3160W
160	4	ELJBE4160W
250	3	ELJBE3250W
250	4	ELJBE4250W

**Note**

① Shunt trip and undervoltage release cannot be used in an EG breaker connected to an earth leakage module.

## LG-Frame

**LG-Frame Ground Fault Modules, UL-Rated (Bottom Mounted, 120–480 Vac, 50/60 Hz)**

Ampere Rating	Number of Poles	Catalog Number
400	3	ELLBN3400W
400	4	ELLBN4400W
600	3	ELLBN3600W
600	4	ELLBN4600W

**LG-Frame Earth Leakage Modules, IEC-Rated (Bottom Mounted, 230–415 Vac, 50/60 Hz)**

Ampere Rating	Number of Poles	Catalog Number
400	3	ELLBE3400W
400	4	ELLBE4400W
630	3	ELLBE3630W
630	4	ELLBE4630W

# 2.2

## Molded Case Circuit Breakers

### Series G

#### Dimensions

Approximate Dimensions in Inches (mm)

2

#### Assembled Breaker and Earth Leakage Module

Frame	Height	Width	Depth
<b>Three-Pole</b>			
EG	10.25 (260.3)	3.00 (76.2)	2.98 (75.8)
JG	11.25 (285.8)	4.13 (104.9)	3.57 (90.7)
LG	15.38 (390.7)	5.48 (139.2)	4.06 (103.1)
<b>Four-Pole</b>			
EG	10.25 (260.3)	4.00 (101.6)	2.98 (75.8)
JG	11.25 (285.8)	5.50 (139.7)	3.57 (90.7)
LG	15.38 (390.7)	7.23 (183.6)	4.06 (103.1)

#### EG-Frame With Earth Leakage Module

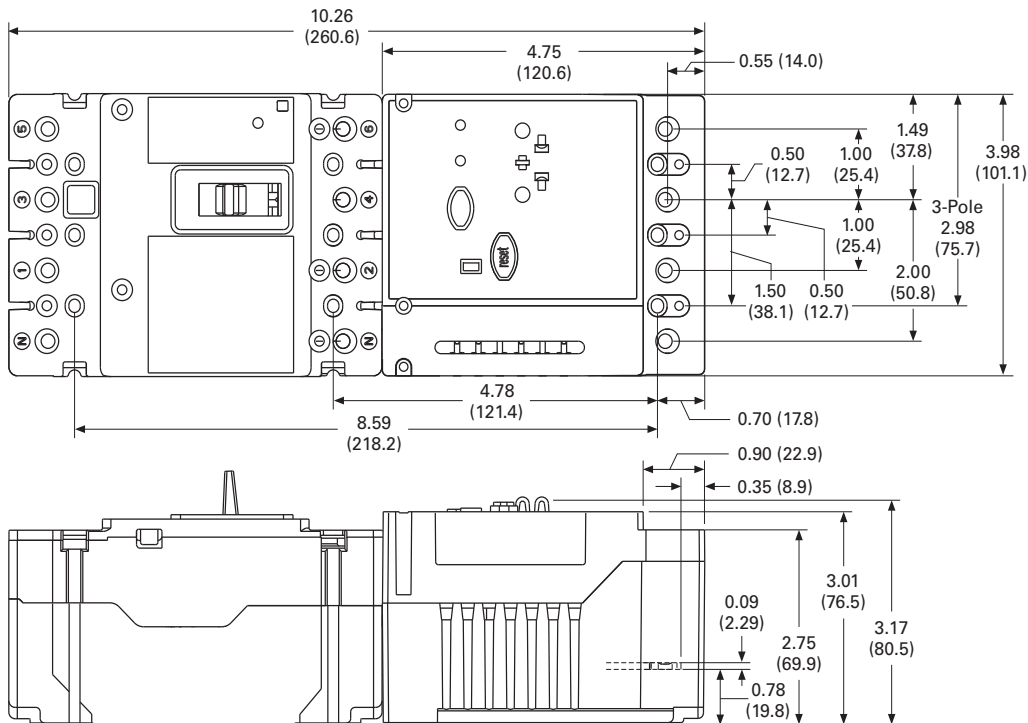

JG-Frame With Earth Leakage Module

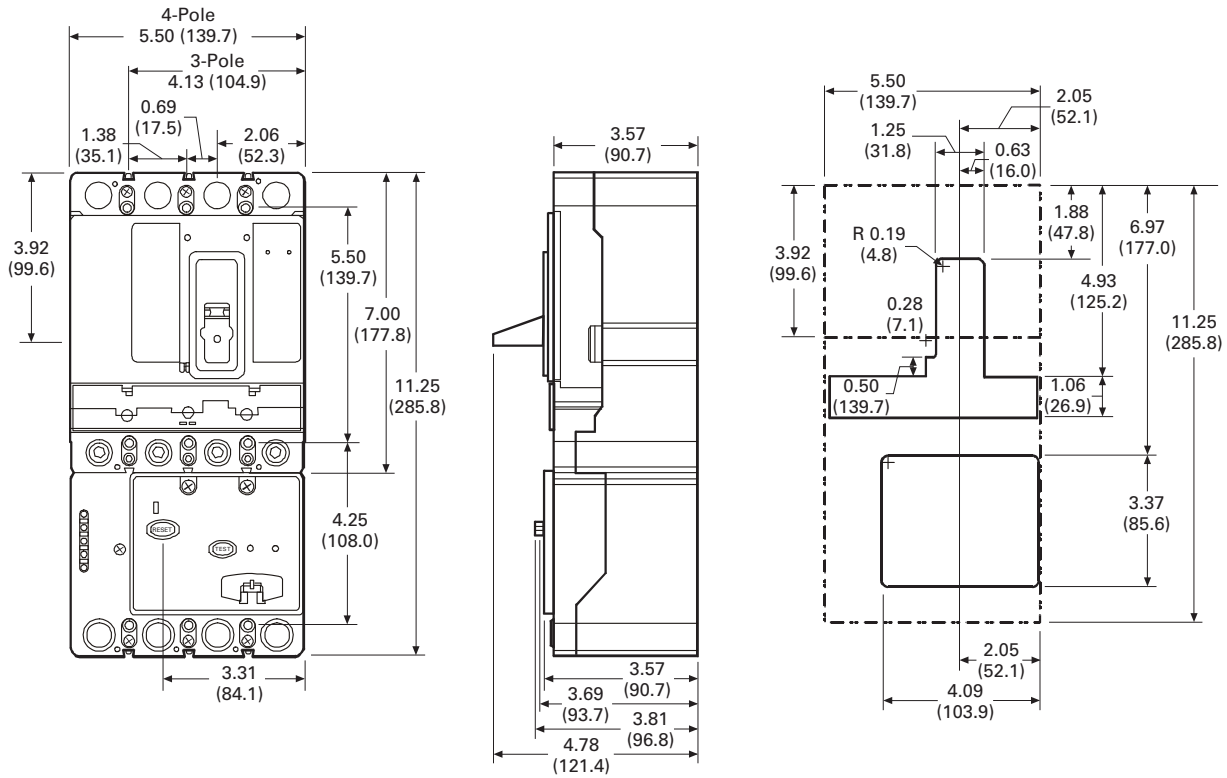

LG-Frame With Earth Leakage Module

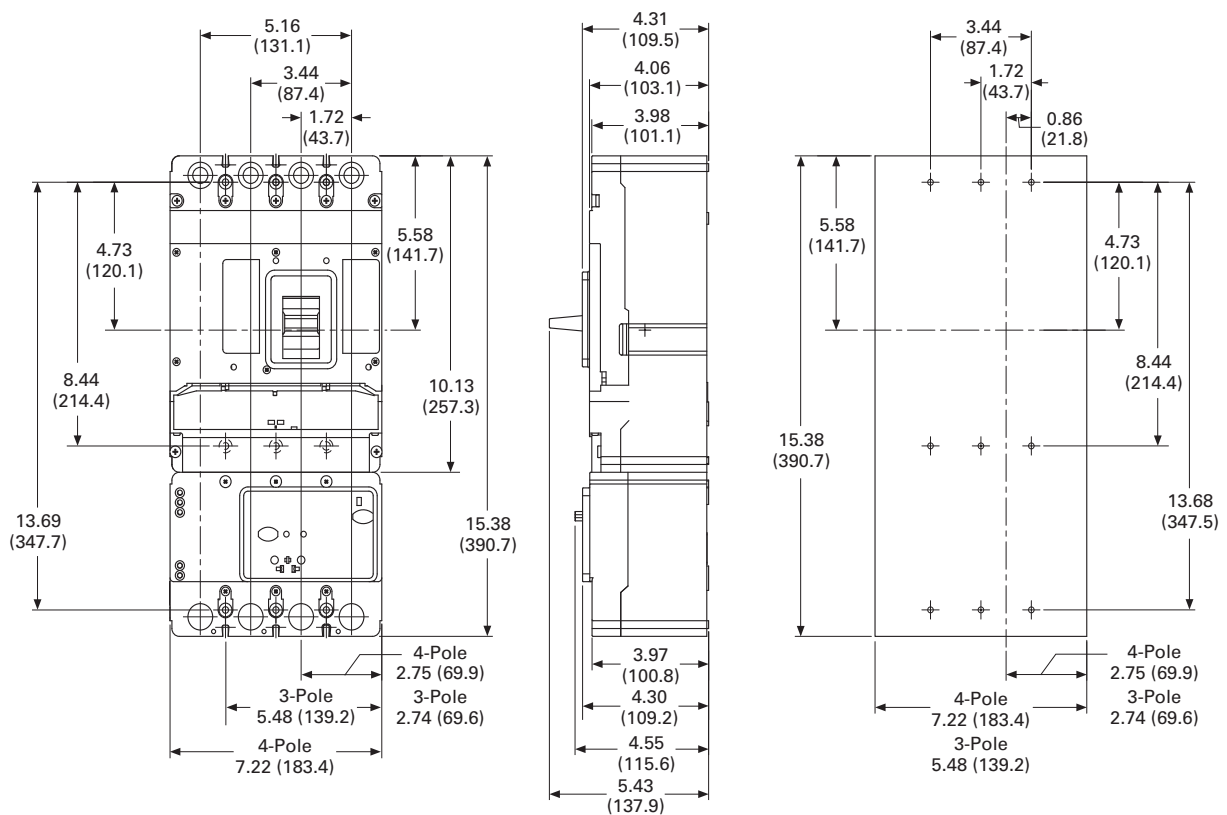

## Current Limiting Circuit Breaker Modules



## Current Limiting Circuit Breaker Module

## Product Overview

Power demand continues to grow in new and existing facilities. To meet increased demand, larger utility supplies, spot networks and large facility transformers are installed. The increased capacity of the electrical source results in increased fault currents in excess of 100 kA short-circuit protection. Eaton manufactures non-fused current limiting modules with interrupting capacities up to 200 kA at 600 Vac or 70 kA at 690 Vac. Unlike fused current limiters with a one-time use, a current limiter module provides an automatic reset of the module after a short-circuit event. Resetting the molded-case circuit breaker is the only action required to restore critical power to the system; there is no time wasted with sourcing the correct replacement fuses or module to bring system back online.

## Product Description

The current limiting breaker modules use a unique contact design to enhance the system protection similar to that of the circuit breaker. When high short-circuit current is flowing through the contacts of these modules, the design results in very high interrupting capacities and improved current limiting characteristics.

## Application Description

High-performance breakers are most commonly applied when very high fault levels are available and with applications where the current limiting capability is used upstream of the final load to limit current. Typical loads include lighting, power distribution, and motor control applications.

## Contents

<b>Description</b>	<b>Page</b>
EG-Frame (15–125 Amperes) . . . . .	<b>V4-T2-15</b>
JG-Frame (63–250 Amperes) . . . . .	<b>V4-T2-29</b>
LG-Frame (250–630 Amperes) . . . . .	<b>V4-T2-47</b>
NG-Frame (320–1200 Amperes) . . . . .	<b>V4-T2-65</b>
RG-Frame (800–2500 Amperes) . . . . .	<b>V4-T2-74</b>
Motor Circuit Protectors (MCP) . . . . .	<b>V4-T2-85</b>
Motor Protector Circuit Breakers (MPCB) . . . . .	<b>V4-T2-89</b>
30 mA Ground Fault (Earth Leakage) Module . . . . .	<b>V4-T2-92</b>
Current Limiting Circuit Breaker Module	
Product Selection . . . . .	<b>V4-T2-97</b>
Technical Data and Specifications . . . . .	<b>V4-T2-98</b>
Dimensions and Weights . . . . .	<b>V4-T2-98</b>
High Instantaneous Circuit Breaker for	
Selective Coordination . . . . .	<b>V4-T2-101</b>
Special Features and Accessories . . . . .	<b>V4-T2-104</b>
Motor Operators . . . . .	<b>V4-T2-112</b>
Plug-In Blocks . . . . .	<b>V4-T2-114</b>
Drawout Cassette . . . . .	<b>V4-T2-115</b>

## Features and Benefits

Superior system protection:

- Auto reset improves system uptime and eliminates the need for finding replacement parts
- No fuses to replace, reducing the overall cost of ownership and the waste created by fuses
- Overloads, by using inverse time current tripping characteristics of the molded-case circuit breaker
- Low-level short circuits, by using instantaneous and/or short-time delay tripping characteristics of the molded-case circuit breaker
- High-level short circuits, by using ultra-high-speed, blow-apart contacts of the current limiting module in series with the circuit breaker contacts
- Let-through currents, by improved opening speed of the contacts, the resultant rapid rise of arc voltage introduces impedance into the system

## Standards and Certifications

- IEC 60947-2
- UL 489
- CSA C22.2



## Product Selection

## Series G High Performance Family Offering

Type	Product	Amperes	480 Vac (UL)		415 Vac (IEC)		690 Vac (IEC)	
			600 Vac (UL)	I <sub>cu</sub>	I <sub>cs</sub>	I <sub>cu</sub>	I <sub>cs</sub>	
EGC 3P thermal-magnetic	Breaker only	15–125	100	35 <sup>①</sup>	100	100	—	—
	With limiter	15–100	150	100 <sup>①</sup>	150	150	—	—
JG 3P thermal-magnetic	Breaker only	70–250	200	50	200	200	18	14
	With limiter	70–225	200	200	200	150	70	18
JG 3P electronic	Breaker only	20–250	200	50	200	200	18	14
	With limiter	100–250	200	200	200	150	70	18
LG 3P thermal-magnetic	Breaker only	250–600	200	65	200	200	35	18
LG3P electronic	Breaker only	100–600	200	65	200	200	35	18

## EG-Frame



## EG IC Rating— 150 kAIC at 415 and 480 Vac

UL Listed (NEMA/IEC Rated) Base Molded Case Circuit Breaker	Breaker with Line Side Mounted Current Limiter	Breaker with Load Side Mounted Current Limiter	Line and Load Terminations Included <sup>②</sup>	Interphase Barrier Included for Limiter
EGC3015FFG	EGC3015FFGQ01	EGC3015FFGQ02	T125EF	EIPBSK
EGC3016FFG	EGC3016FFGQ01	EGC3016FFGQ02	T125EF	EIPBSK
EGC3020FFG	EGC3020FFGQ01	EGC3020FFGQ02	T125EF	EIPBSK
EGC3025FFG	EGC3025FFGQ01	EGC3025FFGQ02	T125EF	EIPBSK
EGC3030FFG	EGC3030FFGQ01	EGC3030FFGQ02	T125EF	EIPBSK
EGC3032FFG	EGC3032FFGQ01	EGC3032FFGQ02	T125EF	EIPBSK
EGC3035FFG	EGC3035FFGQ01	EGC3035FFGQ02	T125EF	EIPBSK
EGC3040FFG	EGC3040FFGQ01	EGC3040FFGQ02	T125EF	EIPBSK
EGC3045FFG	EGC3045FFGQ01	EGC3045FFGQ02	T125EF	EIPBSK
EGC3050FFG	EGC3050FFGQ01	EGC3050FFGQ02	T125EF	EIPBSK
EGC3060FFG	EGC3060FFGQ01	EGC3060FFGQ02	T125EF	EIPBSK
EGC3063FFG	EGC3063FFGQ01	EGC3063FFGQ02	T125EF	EIPBSK
EGC3070FFG	EGC3070FFGQ01	EGC3070FFGQ02	T125EF	EIPBSK
EGC3080FFG	EGC3080FFGQ01	EGC3080FFGQ02	T125EF	EIPBSK
EGC3090FFG	EGC3090FFGQ01	EGC3090FFGQ02	T125EF	EIPBSK
EGC3100FFG	EGC3100FFGQ01	EGC3100FFGQ02	T125EF	EIPBSK

## Notes

<sup>①</sup> 600Y/347V.

<sup>②</sup> Two interphase barriers included on line end mounted limiter; (2) line end of limiter. Four interphase barriers included on load end mounted limiter; (2) line end of breaker (2) load end of limiter.

#### Technical Data and Specifications

2

##### UL 489 Current Limiting Data

Frame	Circuit	$I_p$ (kA)	$I^2T$ ( $10^6 A^2S$ )
EGC...Q	240 V/150 kA	21.80	0.277
EGC...Q	480 V/150 kA	21.80	0.277
EGC...Q	600 V/100 kA	22.60	0.387

#### Dimensions and Weights

Approximate Dimensions in Inches (mm)

##### Assembled Breaker and Current Limiting Module

Frame	Height	Width	Depth	Weight in lbs (kg)
EG	9.66 (245.7)	3.00 (76.2)	2.98 (75.8)	2.91 (1.32)
HMCP	9.66 (245.7)	3.00 (76.2)	2.98 (75.8)	4.18 (1.90)

##### EG-Frame With Current Limiter Module

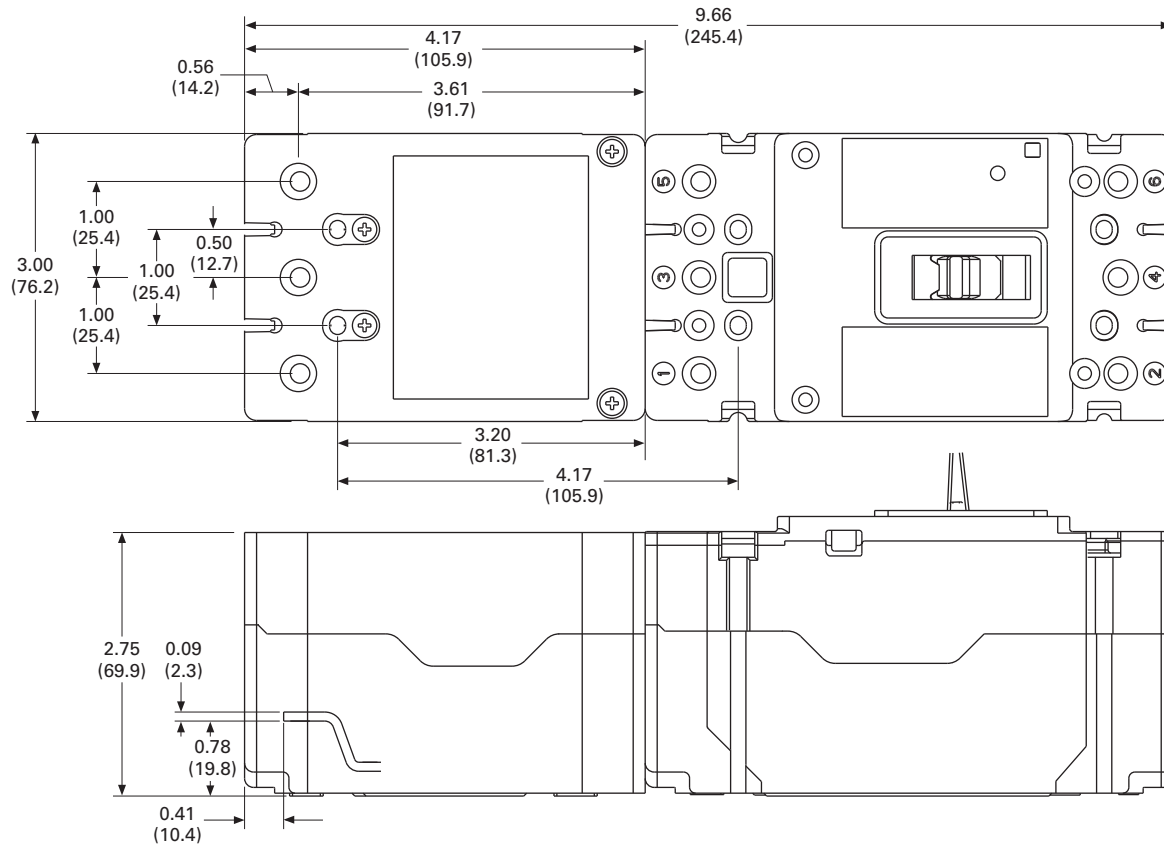

## JG Frame



## JG IC Rating—200 kAIC at 600 Vac and 70 kAIC at 690 Vac

Ampere Rating	Magnetic Range	UL Listed, IEC Rated Breaker With Line Side Mounted Current Limiter <sup>①</sup>	UL Listed, IEC Rated Breaker With Load Side Mounted Current Limiter <sup>②</sup>	IEC Rated Breaker With Line Side Mounted Current Limiter <sup>①</sup>	IEC Rated Breaker With Load Side Mounted Current Limiter <sup>②</sup>
		Fixed Thermal, Adjustable Magnetic	Adjustable Thermal, Adjustable Magnetic		
70	350–700	JGH3070FAGQ01	JGH3070FAGQ02	—	—
90	450–900	JGH3090FAGQ01	JGH3090FAGQ02	—	—
100	500–1000	JGH3100FAGQ01	JGH3100FAGQ02	JGH3100AAGQ01	JGH3100AAGQ02
125	625–1250	JGH3125FAGQ01	JGH3125FAGQ02	JGH3125AAGQ01	JGH3125AAGQ02
150	750–1550	JGH3150FAGQ01	JGH3150FAGQ02	—	—
160	800–1600	—	—	JGH3160AAGQ01	JGH3160AAGQ02
175	875–1750	JGH3175FAGQ01	JGH3175FAGQ02	—	—
200	1000–2000	JGH3200FAGQ01	JGH3200FAGQ02	JGH3200AAGQ01	JGH3200AAGQ02
225	1125–2250	JGH3225FAGQ01	JGH3225FAGQ02	—	—
<b>Electronic Trip LS</b>					
250	—	JGH325033GQ01	JGH325033GQ02	—	—
<b>Electronic Trip LSI</b>					
250	—	JGH325032GQ01	JGH325032GQ02	—	—
<b>Electronic Trip LSG</b>					
250	—	JGH325035GQ01	JGH325035GQ02	—	—
<b>Electronic Trip LSIG</b>					
250	—	JGH325036GQ01	JGH325036GQ02	—	—

## Series G HMCP

Ampere Rating	Motor Circuit Protector with Line Side Mounted Current Limiter	Breaker with Load Side Mounted Current Limiter
250	HMCPJ250D5LQ01	HMCPJ250D5LQ02
250	HMCPJ250F5LQ01	HMCPJ250F5LQ02
250	HMCPJ250G5LQ01	HMCPJ250G5LQ02
250	HMCPJ250J5LQ01	HMCPJ250J5LQ02
250	HMCPJ250K5LQ01	HMCPJ250K5LQ02
250	HMCPJ250L5LQ01	HMCPJ250L5LQ02

## Line and Load Terminals

Maximum Breaker Amperes	Terminal Body Material	Wire Type	Metric Wire Range mm <sup>2</sup>	AWG Wire Range/ Number of Conductors	Catalog Number
<b>Standard Pressure Type Terminals</b>					
250	Aluminum	Cu/Al	10–185	#8–350 (1)	TA250FJ <sup>③</sup>

## Notes

- ① Two interphase barriers provided, mounted on line end of limiter, catalog number FJIPBK.  
 ② Four interphase barriers provided, (2) line end of breaker, (2) load end of limiter.  
 ③ Line and load terminals included with products listed above.

### Technical Data and Specifications

2

#### UL 489 Current Limiting Data

Frame	Circuit	I <sub>p</sub> (kA)	I <sup>2</sup> T (10 <sup>6</sup> A <sup>2</sup> S)
JGH...Q	240 V/200 kA	48.60	2.47
JGH...Q	480 V/200 kA	48.60	2.47
JGH...Q	600 V/200 kA	48.60	2.47

### Dimensions and Weights

Approximate Dimensions in Inches (mm)

#### Assembled Breaker and Current Limiting Module

Frame	Height	Width	Depth	Weight in lbs (kg)
JG + limiter	13.06 (331.7)	4.13 (104.9)	3.44 (87.4)	9.87 (4.48)
HMCP	13.06 (331.7)	4.13 (104.9)	3.44 (87.4)	9.87 (4.48)

#### JG-Frame With Current Limiter Module

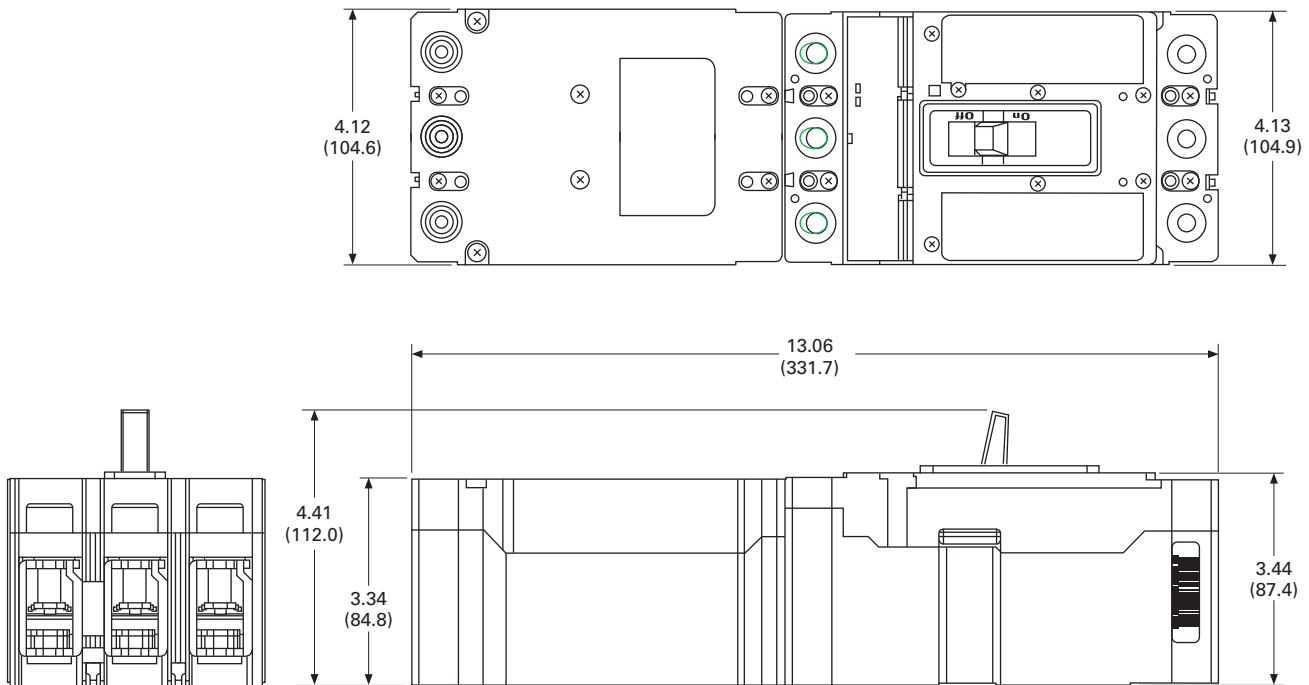

**High Instantaneous Circuit Breaker for Selective Coordination****Contents**

<b>Description</b>	<b>Page</b>
EG-Frame (15–125 Amperes) . . . . .	<b>V4-T2-15</b>
JG-Frame (63–250 Amperes) . . . . .	<b>V4-T2-29</b>
LG-Frame (250–630 Amperes) . . . . .	<b>V4-T2-47</b>
NG-Frame (320–1200 Amperes) . . . . .	<b>V4-T2-65</b>
RG-Frame (800–2500 Amperes) . . . . .	<b>V4-T2-74</b>
Motor Circuit Protectors (MCP) . . . . .	<b>V4-T2-85</b>
Motor Protector Circuit Breakers (MPCB). . . . .	<b>V4-T2-89</b>
30 mA Ground Fault (Earth Leakage) Module . . . . .	<b>V4-T2-92</b>
Current Limiting Circuit Breaker Module . . . . .	<b>V4-T2-96</b>
High Instantaneous Circuit Breaker for Selective Coordination	
Product Selection . . . . .	<b>V4-T2-102</b>
Technical Data and Specifications . . . . .	<b>V4-T2-103</b>
Dimensions . . . . .	<b>V4-T2-103</b>
Special Features and Accessories . . . . .	<b>V4-T2-104</b>
Motor Operators . . . . .	<b>V4-T2-112</b>
Plug-In Blocks . . . . .	<b>V4-T2-114</b>
Drawout Cassette . . . . .	<b>V4-T2-115</b>

**High Instantaneous Circuit Breaker for Selective Coordination****Product Description**

Eaton's Electrical Sector introduces new high-magnetic withstand molded case circuit breakers, specifically designed for critical operations and selective coordination requirements. The high-magnetic withstand LHH and NHH frames continue the legacy of circuit breaker innovation for which Eaton is recognized throughout the world. The LHH and NHH breakers are equipped with 125 to 400 ampere trip units with high-magnetic capability. This design enables the breakers to withstand up to 90 times rated current before opening under short-circuit conditions.

The LHH and NHH circuit breakers incorporate a higher level of instantaneous pickup, thus allowing for higher current levels of selective coordination. Standard molded case circuit breakers typically are furnished with a magnetic pickup or electronic instantaneous adjustment or instantaneous override set at 10 times (10x) the continuous trip rating.

**Features, Benefits and Functions**

Eaton's new LHH and NHH molded case circuit breakers are furnished with a higher level of magnetic pickup or electronic instantaneous settings as indicated in table on **Page V4-T2-103**. These higher levels of magnetic pickup and electronic instantaneous values in turn allow the system designer to obtain selective coordination at fault current levels up to these higher ratings. Greater values of selective coordination are available based on manufacturer tested combinations using the LHH and NHH as line-side breakers and standard breakers as load-side devices. Refer to IA01200002E to determine the maximum fault values that selective coordination achieves. When the line-side and load-side molded case circuit breaker trip ratings are chosen to coordinate in the overload range, they also can be selectively coordinated in the fault range up to the values listed in the table on **Page V4-T2-103** or IA01200002E. For overcurrents protected by circuit breakers on the load-side of the LHH or NHH, only the effected load-side

circuit breaker will open, while the line-side LHH and/or NHH circuit breakers remain closed, thus providing continuity of power to the other critical loads supplied by the LHH or NHH circuit breakers.

**Benefits of Using the LHH and NHH Molded Case Circuit Breakers**

Customer expectations and codes are driving product development to protect customers' critical operations. NEC® 2005 and 2008 requires circuits with elevators, emergency systems, legally required standby systems, health care essential systems and critical operation power systems to be selectively coordinated. Simply stated, only the closest protective device directly protecting the circuit having an overcurrent (overload or fault) condition should open.

All other overcurrent protective devices within these systems shall remain closed. Similarly, backup power system designs of a critical nature that are not code mandated may also require overcurrent protective devices to be selectively coordinated as much as practicable to provide a higher level of uptime.

## Product Selection

LHH



## LHH and NHH Catalog Numbers

Ampere Rating	Thermal-Magnetic Trip Unit		LSI Electronic Trip Unit
	LHH Frame	NHH Frame	
125	LHH3125FFG	—	
150	LHH3150FFG	NHH3150T52X15	
175	LHH3175FFG	NHH3175T52X15	
200	LHH3200FFG	NHH3200T52X15	
225	LHH3225FFG	NHH3225T52X15	
250	LHH3250FFG	NHH3250T52X15	
300	LHH3300FFG	NHH3300T52X15	
350	LHH3350FFG	NHH3350T52X15	
400	LHH3400FFG	—	

## 2 Proven Technology and Performance

The LHH is based on the Series G L-Frame circuit breaker, sharing the same small footprint and field-fit accessories as the L-Frame breaker. The NHH is based on the Series G N-Frame circuit breaker and shares the same footprint and accessories as the N-Frame breaker. NHH accessories must be factory installed.

The LHH incorporates a thermal-magnetic trip unit with fixed thermal and fixed magnetic settings. The NHH has an OPTIM™ electronic trip unit with LSI adjustment capabilities. The instantaneous setting is adjustable from 1000–4000 A or may be turned off to default to the frame override of 14,000 A. A hand-held OPTIMizer must be used with the NHH to adjust short-time delay and instantaneous, however, the long delay pickup is fixed and cannot be adjusted.

The LHH and NHH breakers are available in Eaton's panelboards and switchboards.

### Standards and Certifications

- UL
- CSA



Listed

**Technical Data and Specifications**

- Three-pole
- 65 kAIC at 480 Vac
- 125–400 ampere LHH
- 150–350 ampere NHH
- Trip units:
- LHH—thermal-magnetic
- NHH—LSI electronic trip unit
- No rating plugs required
- Factory-sealed breakers
- LHH uses same internal and external accessories as standard Series G L-Frame circuit breaker
- NHH uses same internal and external accessories as standard Series G N-Frame circuit breaker

**LHH and NHH Electrical Characteristics**

**Short-Circuit Current Ratings (kA rms) AC 50–60 Hz**

Description	Breaker Type	
	LHH	NHH
Max. rated current (amperes)	400	350
NEMA UL 489		
240 Vac	100	100
480 Vac	65	65
600 Vac	35	35
250 Vac	42	—
IEC 60947-2		
220 Vac	100	100
415 Vac	70	70
690 Vac	25	25
125/250 Vdc	22	—
Number of poles	3	3
Ampere range	125–400 A	150–350 A

**Continuous Current Ratings**

Continuous Current Rating (I <sub>c</sub> )	Magnetic Trip Point	Continuous Current Multiplier	Instantaneous Trip Point	Continuous Current Multiplier	Short Delay Pickup
125 A	2500 A	20x	—	—	—
150 A	2500 A	16x	14,000 A	93x	225–1200 A
175 A	4000 A	22x	14,000 A	80x	260–1400 A
200 A	4000 A	20x	14,000 A	70x	300–1600 A
225 A	6000 A	26x	14,000 A	62x	338–1800 A
250 A	6000 A	24x	14,000 A	56x	375–2000 A
300 A	6000 A	20x	14,000 A	47x	450–2400 A
350 A	6000 A	17x	14,000 A	40x	525–2800 A
400 A	6000 A	15x	—	—	—

**Dimensions**

Approximate Dimensions in Inches (mm)

**Dimensions**

Description	Height	Width	Depth	Weight in Lbs (kg)
LHH	10.13 (257.3)	5.48 (139.2)	4.09 (103.9)	12.36 (5.6)
NHH	16.00 (406.4)	8.25 (209.5)	5.50 (139.7)	46.80 (21.2)

**L-Frame**

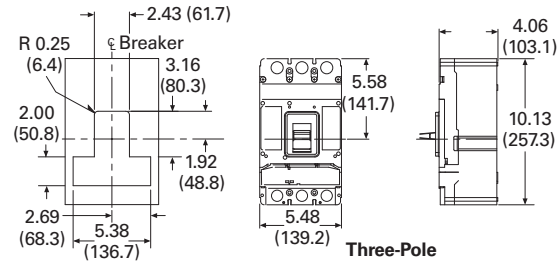

**N-Frame**

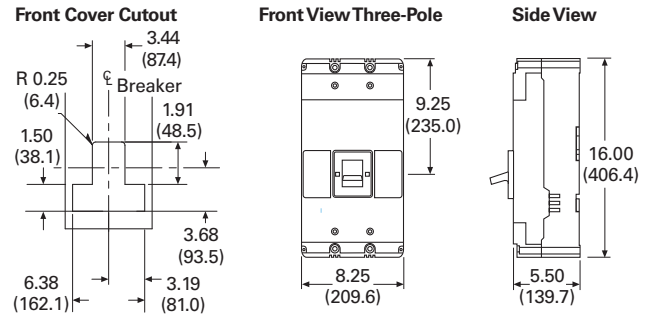

### Contents

<i>Description</i>	<i>Page</i>
EG-Frame (15–125 Amperes) . . . . .	<b>V4-T2-15</b>
JG-Frame (63–250 Amperes) . . . . .	<b>V4-T2-29</b>
LG-Frame (250–630 Amperes) . . . . .	<b>V4-T2-47</b>
NG-Frame (320–1200 Amperes) . . . . .	<b>V4-T2-65</b>
RG-Frame (800–2500 Amperes) . . . . .	<b>V4-T2-74</b>
Motor Circuit Protectors (MCP) . . . . .	<b>V4-T2-85</b>
Motor Protector Circuit Breakers (MPCB) . . . . .	<b>V4-T2-89</b>
30 mA Ground Fault (Earth Leakage) Module . . . . .	<b>V4-T2-92</b>
Current Limiting Circuit Breaker Module . . . . .	<b>V4-T2-96</b>
High Instantaneous Circuit Breaker for Selective Coordination . . . . .	<b>V4-T2-101</b>
Special Features and Accessories	
Internal Accessories . . . . .	<b>V4-T2-106</b>
External Accessories and Test Kit . . . . .	<b>V4-T2-107</b>
Accessories . . . . .	<b>V4-T2-109</b>
Motor Operators . . . . .	<b>V4-T2-112</b>
Plug-In Blocks . . . . .	<b>V4-T2-114</b>
Drawout Cassette . . . . .	<b>V4-T2-115</b>

### Special Features and Accessories

Eaton’s molded case circuit breakers are designed to provide circuit protection for low voltage distribution systems. They are described by NEMA as, “... a device for closing and interrupting a circuit between separable contacts under both normal and abnormal conditions,” and furthermore as, “... a breaker assembled as an integral unit in a supporting and enclosing housing of insulating material.” The National Electrical Code (NEC) describes them as, “A device designed to open and close a circuit by non-automatic means, and to open the circuit automatically on a predetermined overload of current, without injury to itself when properly applied within its rating.”

So designed, Eaton circuit breakers protect conductors against overloads and conductors and connected apparatus, such as motors and motor starters, against short circuits.

In low voltage distribution systems, there are many varied applications of molded case circuit breakers. Eaton offers the most comprehensive family of molded case circuit breakers in the industry.

This section of circuit breakers includes:

- Thermal-magnetic trip breakers
- Electronic rms trip breakers
- Molded case switches
- Motor circuit protectors
- Current limiting breakers
- Special application breakers

#### Modified Breakers

Eaton breakers can be ordered with internal accessories installed. These modified breakers will be subject to an addition charge.

### Special Calibration

Special non-UL listed calibrations are available for certain ambient temperatures other than 40 °C and for frequencies other than 50/60 Hz or DC. Reduced interrupting ratings will apply for 400 Hz applications.

- Add suffix H01 to breaker catalog number for 400 Hz rating

### 50 °C Calibration

**Note:** Breakers equipped with electronic trip units can operate reliably in ambient temperatures of 50 °C. Add suffix “V3” to NG MCCBs to remove standard 40 °C labeling.

Add suffix “V” to catalog number for complete thermal magnetic breaker when ordering listed ampere ratings for breakers to be used in 50 °C ambients. 50 °C ambient MCCBs are not UL listed.

Contact Eaton for availability.

### Calibrations and Treatment

Description	Frame				
	EG	JG	LG	NG	RG
Special calibration	■	■	■	■	■
Moisture-fungus treatment	■	■	■	■	■

**Moisture-Fungus Treatment**

All Eaton circuit breaker cases are molded from glass-polyester, which does not support the growth of fungus. Any parts that are susceptible to the growth of fungus will require special treatment.

Order by description.

- Add suffix J01 to breaker catalog number

**Freeze-Tested Circuit Breakers**

The circuit breakers may be ordered with freeze testing. This option uses special lubrication and mechanical operation is verified at  $-40^{\circ}\text{C}$ .

- Add suffix F01 to catalog number  $-57^{\circ}\text{F}$ , F02  $-30^{\circ}\text{F}$

**Marine Applications**

E- to R-Framed circuit breakers can be supplied to meet the following marine specifications:

- U.S. Coast Guard CFR 46; ABS—American Bureau of Shipping; IEEE 45; DNV; and Lloyds

These specifications generally require molded case circuit breakers to be supplied with  $50^{\circ}\text{C}$  ambient, and plug-in adapter kits. When plug-in adapter kits are used, no terminals need be supplied (switchboard applications).

Circuit breakers can also be supplied to meet UL 489 Supplement SA (Marine use) and UL 489 Supplement SB (Naval Use).

UL 489 Supplement SA applies to vessels over 65 feet (19.8m) in length.

Requirements include  $40^{\circ}\text{C}$  ambient calibration, special labeling, and no use of aluminum conductors or terminals. (No  $50^{\circ}\text{C}$ .)

- Add suffix H08

Or you can choose to add  $50^{\circ}\text{C}$  ambient but then there is no "UL" mark.

- Add suffix VH08

UL 489 Supplement SB requires partial  $50^{\circ}\text{C}$  ambient calibration, vibration testing, special nameplating and no use of aluminum conductors or terminals. Eaton chooses to always fully calibrate to  $50^{\circ}\text{C}$  ambient. ("Naval" labeled per UL but no "UL" mark due to  $50^{\circ}\text{C}$  label.)

- Add suffix VH09

**Certified Test Reports**

Eaton breakers can be ordered with certified test reports at the time of order entry. Test report documents the thermal and magnetic or electronic tripping characteristics of the individual breaker. Breaker and test report must be ordered together. Add suffix 12 to breaker catalog number and enter separate line item on order for certified test report.

**Standards and Certifications**

Molded case circuit breakers are designed to conform with the following standards:

- Underwriters Laboratories Inc., Standard UL 489, molded case circuit breakers and circuit breaker enclosures
- National Electrical Manufacturers Association (NEMA) Standards Publication No. AB1-1993, molded case circuit breakers
- Australian Standard AS 2184, molded case circuit breakers
- British Standards Institution Standard BS 4752: Part 1, switchgear and control gear Part 1: circuit breakers
- Canadian Standards Association (CSA) Standard C22.2 No. 5, service entrance and branch circuit breakers
- International Electrotechnical Commission Recommendations IEC 60947-2, circuit breakers
- Japanese T-Mark Standard molded case circuit breakers
- South African Bureau of Standards, Standard SABS 156, Standard Specification for molded case circuit breakers
- Swiss Electro-Technical Association Standard SEV 157-1, safety regulations for circuit breakers
- Union Technique de l'Electricite Standard NF C 63-120, low voltage switchgear and control gear circuit breaker requirements
- Verband Deutscher Elektrotechniker (Association of German Electrical Engineers) Standard VDE 0660, low voltage switchgear and control gear, circuit breakers

Conformance with these standards satisfies most local and international codes, assuming user acceptability and simplified application.

Molded case circuit breakers equal or exceed Federal Specification Classification W-C-375b requirements for the particular class associated with the circuit breaker frame being considered.

Open breakers do not have service entrance ratings. Service entrance rating is part of the enclosure.



## Internal Accessories

### Alarm Lockout

The alarm switches operate when the circuit breaker is tripped by a short circuit or overcurrent, but also when it is tripped by a shunt trip or undervoltage release.

### Auxiliary Switches

Auxiliary switches are used for signaling and control purposes. The various functions of the auxiliary switches (changeover) are shown on **Page V4-T2-108**.

### Shunt Trips

The shunt trip is used for remote tripping.

The coil of the shunt trip is rated only for short-time operation.

It is not permissible with the circuit breaker open to apply a continuous opening command to the shunt trip in order to prevent the breaker from closing. This means that interlocking circuits with continuous commands may not be set up with shunt trips.

### Undervoltage Releases

The circuit breaker cannot be closed until the undervoltage release is energized. If the release is not energized, the circuit breaker can only perform an idle switching operation.

Frequent idle switching actions should be avoided as they shorten the endurance of the circuit breaker.

## Digitrip 310+ Electronic Trip Unit Accessories

### Cause of Trip Display/Remote Mount Cause of Trip Display

The Cause of Trip Display can be field-installed on any Digitrip RMS 310+ trip unit. The device provides breaker information through an LCD screen, such as cause of trip, phrase current, ground current and low loads. The display is ideal for troubleshooting common trips such as ground fault, long delay, and instantaneous/short delay. The DIGIVIEW version will provide a local display at the breaker without additional wiring by connecting directly onto the trip unit. The DIGIVIEWR06 version has a 6 foot cable that allows users to mount the display on the outside of an enclosure door and connect to the trip unit that is contained inside the enclosure.

The DIGIVIEWR06 is NEMA 3R rated.

### Cause of Trip Display/Remote Mount Cause of Trip Display

Catalog  
Number

---

DIGIVIEW

---

DIGIVIEWR06

### Cause of Trip LED Module

The Cause of Trip LED Module can be field-installed on any Digitrip RMS 310+ trip unit. The device provides a cause of trip indication via LED. The Cause of Trip LED Module connects directly onto the trip unit. When the breaker trips, the module indicates the cause of trip (long delay, short delay, instantaneous and ground) via LED indication. The module is reset after the breaker is reset.

### Cause of Trip LED Module

Catalog  
Number

---

TRIP-LED

### Electronic Portable Test Kit

The electronic portable test kit provides a means to complete field tests using secondary injection on all 310+ trip units. The same test kit is also capable of secondary injection testing on Magnum and Series NRX low voltage power circuit breakers' 520 and 1150 trip units.

### Electronic Portable Test Kit

Catalog  
Number

---

MTST230V

### Wire Seal

The wire seal can be used to secure the cover of the trip unit to prevent adjustments after settings are confirmed.

### Wire Seal

Catalog  
Number

---

5108A03H01

## External Accessories and Test Kit

## External Accessories

Description	Fit Type	Frame				
		EG	JG	LG	NG	RG
Non-padlockable handle block	Field	EFHB	—	—	LKD4	—
Padlockable handle block	Field	EFPHB	—	—	—	—
Padlockable handle block off-only	Field	EFPHBOFF	FJPHBOFF	LBHPOFF	—	—
Padlockable handle lock hasp	Field	EFPLK	FJPHL	LPHL	PLK5	HLK6
Padlockable handle lock hasp off-only	Field	EFPHLOFF	FJPHLOFF	LPHLOFF	PLK55OFF	HLK6OFF
Kirk key interlock kit <sup>①②</sup>	Field	—	KYKJG	KYKLG	KYK4	KYK6
Castell key interlock kit <sup>②③</sup>	Field	—	CTKJG	CTKLG	CTK4	CTK6
Slide bar interlock <sup>④</sup>	Field	EFBSI	FJSBI	LGSBI	SBK5	—
Walking beam interlock <sup>④</sup>	Three-pole	EG3WBI	JG3WBI	LG3WBI	WBL5	WBL6
	Four-pole	EG4WBI	JG4WBI	LG4WBI	WBL5	—
Electrical operator <sup>⑤</sup>	120 Vac	MOPEG240C	MOPJG120C	MOPLG120C	EOP5T07	EOP6T08K
	240 Vac	MOPEG240C	MOPJG240C	MOPLG240C	EOP5T11	EOP6T11K
	24 Vdc	MOPEG48D	MOPJG24D	MOPLG24D	EOP5T21	—
	48 Vdc	MOPEG48D	—	—	EOP5T22	EOP6T21K
	125 Vdc	MOPEG120C	MOPJG120C	MOPLG120C	EOP5T26	—
	220 Vdc	—	MOPJG240C	MOPLG240C	—	—
	250 Vdc	—	MOPJG240C	MOPLG240C	—	—
Plug-in adapters	Three-pole	PAD3E	PAD3J	PAD3L	PAD53	—
	Four-pole	PAD4E	PAD4J	PAD4L	—	—
Wohner busbar adapter	Field top	EG-BUS-T	JG-BUS-TB	LG-BUS-TB	—	—
	Field bottom	EG-BUS-B	JG-BUS-TB	LG-BUS-TB	—	—

**Series G MCCB Frames EG, JG, and LG to mount to the SASY 60 mm Wohner Classic System**

- UL file # E197132
- Compact design
- UL508 tested and certified using Wohner system with Eaton breakers
- No line side wiring required
- Up to 630 A MCCB
- Reverse feed possible

**Wohner Busbar Adapter****Wohner Busbar Adapters**

Breaker Frame	Busbar Adapter	Connection Point
EG	EG-BUS-T	Top
EG	EG-BUS-B	Bottom
JG	JG-BUS-TB	Top or bottom
LG	LG-BUS-TB	Top or bottom

**Notes**

- ① Provision only.
- ② See **Page V4-T2-316** for bolt projection dimensions.
- ③ Castell bolt mounting hole must be 10 mm.
- ④ Requires two breakers.
- ⑤ Contact Eaton for availability of operators for EG- and NG-Frames before December 2004.

### Accessory Configurations for EG–RG Circuit Breakers

## 2

### Internal Accessory Configurations

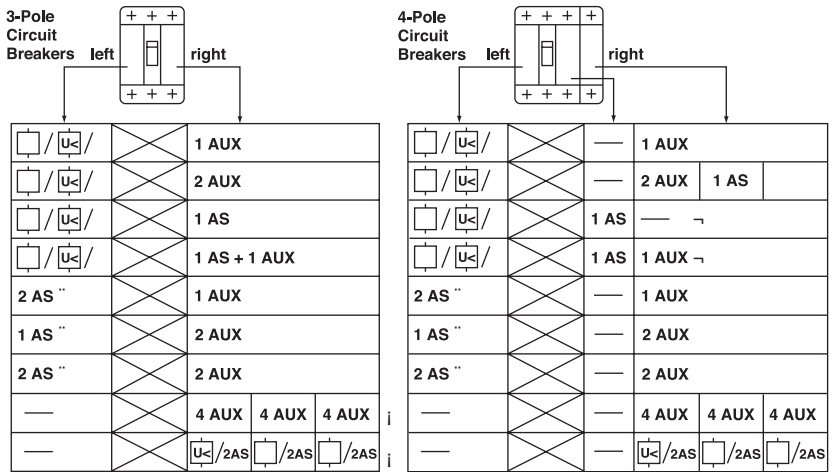

= Shunt Trip or Undervoltage Release

AUX = Auxiliary Switch

AS = Alarm Switch

" = For N-Frame Circuit Breakers Only

≠ = For R-Frame Circuit Breakers Only

↔ = For N and R-Frame Circuit Breakers Only

### Contact Making by the Auxiliary and Alarm Switches as a Function of the Switching Position of the Circuit Breaker

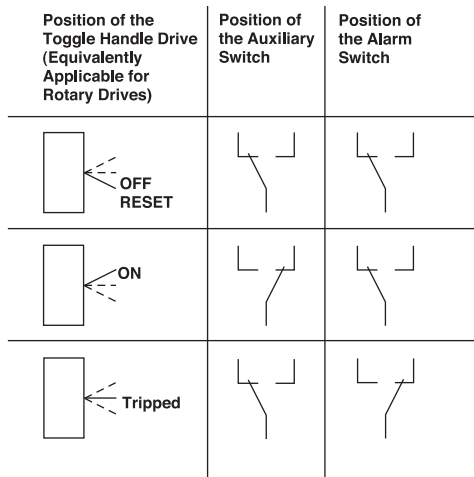

## Accessories

### Field Fit Kit Catalog Numbers

#### Alarm Lockout

Description	Pole Location	Frame		
		EG, JG and LG	NG	RG ①
Make/Break	Left	—	A1L5LPK	—
	Right	ALM1M1BEPK ②	A1L5RPK	A1L6RPK
2 Make/2 Break	Left	—	A2L5LPK	—
	Right	ALM2M2BEPK ③	A2L5RPK	A2L6RPK

Description	Pole Location	For Use in Frame	Contact Type	Catalog Number
Make/Break	Right	EG	Silver	ALM1M1BEPK
2 Make/ 2 Break	Right	EG	Silver	ALM2M2BEPK
Make/Break	Right	JG and LG	Silver	ALM1M1BJPK
2 Make/ 2 Break	Right	JG and LG	Silver	ALM2M2BJPK
Make/Break	Right	EG	Gold	ALM1M1BEEPK
2 Make/ 2 Break	Right	EG	Gold	ALM2M2BEEPK
Make/Break	Right	JG and LG	Gold	ALM1M1BEJPK
2 Make/ 2 Break	Right	JG and LG	Gold	ALM2M2BEJPK

#### Auxiliary Switch

Description	Pole Location	Frame		
		EG, JG and LG	NG	RG ①
1A, 1B	Left	—	A1X5PK	—
	Right	AUX1A1BPK	A1X5PK	—
2A, 2B	Left	—	A2X5PK	—
	Right	AUX2A2BPK	A2X5PK	A2X6RPK
3A, 3B	Left	—	A3X5LPK	—
	Right	—	A3X5RPK	—
4A, 4B	Left	—	—	—
	Right	—	—	A4X6RPK

Description	Pole Location	For Use in Frame	Contact Type	Catalog Number
1A, 1B	Right	EG/JG/LG	Silver	AUX1A1BPK
2A, 2B	Right	EG/JG/LG	Silver	AUX2A2BPK
1A, 1B	Right	EG/JG/LG	Gold	AUX1E1BPK
2A, 2B	Right	EG/JG/LG	Gold	AUX2E2BPK

#### Auxiliary Switch/Alarm Lockout

Description	Pole Location	Frame		
		EG, JG and LG	NG	RG ①
—	Left	—	AA115LPK	—
	Right	AUXALRMEPK ④	AA115RPK	—

Description	Pole Location	For Use in Frame	Contact Type	Catalog Number
1A/1B & 1M/1B	Right	EG	Silver	AUXALRMEPK
1A/1B & 1M/1B	Right	JG and LG	Silver	AUXALRMJPK
1A/1B & 1M/1B	Right	EG	Gold	AUXALRMEEPK
1A/1B & 1M/1B	Right	JG and LG	Gold	AUXALRMEJPK

#### Notes

- ① All accessories mount in the RH cavity which will accept one each of shunt trip, UVR, auxiliary switch and alarm switch.
- ② Part number for JG and LG is ALM1M1BJPK.
- ③ Part number for JG and LG is ALM2M2BJPK.
- ④ Part number for JG and LG is AUXALRMJPK.

## Shunt Trip—Standard

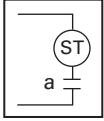

## Shunt Trip—Standard

Description	Pole Location	Frame		
		EG, JG and LG <sup>①</sup>	NG	RG <sup>②</sup>
48–60 Vac	Left	SNT4860CPK	SNT5LP05K	—
	Right	—	—	SNT6P05K
110–240 Vac	Left	SNT120CPK	SNT5LP11K	—
	Right	—	—	SNT6P11K
380–600 Vac	Left	SNT480CPK <sup>③</sup>	—	—
	Right	—	—	—
220–250 Vdc or 380–440 Vac	—	—	SNT5LP14K	SNT6P14K
480–600 Vac	—	—	SNT5LP18K	SNT6P18K
12 Vdc	Left	SNT012CPK	—	—
	Right	—	—	—
24 Vac/dc	Left	SNT024CPK	SNT5LP03K	—
	Right	—	—	SNT6P03K
48–60 Vdc	Left	SNT4860CPK	SNT5LP23K	—
	Right	—	—	SNT6P23K
110–125 Vdc	Left	SNT125DPK	SNT5LP26K	—
	Right	—	—	SNT6P26K
250 Vdc	Left	SNT250DPK	—	—
	Right	—	—	—

## Shunt Trip—Low Energy

Description	Pole Location	Frame		
		EG, JG and LG	NG	RG <sup>②</sup>
—	Left	—	LST5LPK	—
—	Right	—	—	LST6RPK

## Undervoltage Release Mechanism

Description	Pole Location	Frame		
		EG, JG and LG <sup>①</sup>	NG	RG <sup>②</sup>
110–127 Vac	Left	UVR120APK	UVH5LP08K	—
	Right	—	—	UVH6RP08K
208–240 Vac	Left	UVR240APK	UVH5LP11K	—
	Right	—	—	UVH6RP11K
24 Vdc	Left	UVR024DPK	UVH5LP21K <sup>④</sup>	—
	Right	—	—	UVH6RP21K <sup>④</sup>
24 Vac	Left	UVR024APK	UVH5LP21K <sup>④</sup>	—
	Right	—	—	UVH6RP21K <sup>④</sup>
48–60 Vdc	Left	UVR048DPK	UVH5LP23K	—
	Right	—	—	UVH6RP23K
48–60 Vac	Left	UVR048APK	UVH5LP05K	—
	Right	—	—	UVH6RP05K
120 Vdc	Left	UVR125DPK	UVH5LP26K	—
	Right	—	—	UVH6RP26K
220–250 Vdc	Left	UVR250DPK	UVH5LP28K	—
	Right	—	—	UVH6RP28K
380–500 Vac	Left	UVR480APK	UVH5LP29K	—
	Right	—	—	UVH6RP29K
525–600 Vac	Left	UVR600APK	—	—
	Right	—	—	—
12 Vdc	Left	—	UVH5LP20K	—
	Right	—	—	UVH6RP20K
12 Vac	Left	—	UVH5LP02K	—
	Right	—	—	UVH6RP02K

## Notes

- ① LH cavity not available for EG frame with earth leakage module.  
 ② All accessories mount in the RH cavity which will accept one each of shunt trip, UVR, auxiliary switch and alarm switch.  
 ③ 380–600 Vdc, 50/60 Hz.  
 ④ 24 Vdc only use UVH5LP03K (NG) UVH6RP03K (RG) for 24 Vac.

### Technical Data and Specifications

**Note:** Gold-plated contacts are well suited for switching low voltages and currents. Lead wires on accessories containing gold-plated contacts are marked with a yellow stripe.

#### Series G Gold Contact Accessory Switch Electrical Ratings

Max. Voltage (Ue)	Frequency	Max. Current (I <sub>n</sub> )	Dielectric Withstand Voltage (UI)
125 V	50/60 Hz	0.1 A	2200 V
30 V	DC	0.25 A	2200 V
5 V	DC	5 mA	2200 V

#### Series G Silver Contact Accessory Switch Electrical Ratings

Max. Voltage (Ue)	Frequency	Max. Current (I <sub>n</sub> )	Dielectric Withstand Voltage (UI)
600 V	50/60 Hz	2 A	2200 V
125/250 V	50/60 Hz	5 A	2200 V
125 V	DC	1 A	2200 V

#### Series G Motor Operators

2



#### Contents

<i>Description</i>	<i>Page</i>
EG-Frame (15–125 Amperes) . . . . .	<b>V4-T2-15</b>
JG-Frame (63–250 Amperes) . . . . .	<b>V4-T2-29</b>
LG-Frame (250–630 Amperes) . . . . .	<b>V4-T2-47</b>
NG-Frame (320–1200 Amperes) . . . . .	<b>V4-T2-65</b>
RG-Frame (800–2500 Amperes) . . . . .	<b>V4-T2-74</b>
Motor Circuit Protectors (MCP) . . . . .	<b>V4-T2-85</b>
Motor Protector Circuit Breakers (MPCB) . . . . .	<b>V4-T2-89</b>
30 mA Ground Fault (Earth Leakage) Module . . . . .	<b>V4-T2-92</b>
Current Limiting Circuit Breaker Module . . . . .	<b>V4-T2-96</b>
High Instantaneous Circuit Breaker for Selective Coordination . . . . .	<b>V4-T2-101</b>
Special Features and Accessories . . . . .	<b>V4-T2-104</b>
Motor Operators	
Features, Benefits and Functions . . . . .	<b>V4-T2-113</b>
Standards and Certifications . . . . .	<b>V4-T2-113</b>
Product Selection . . . . .	<b>V4-T2-113</b>
Plug-In Blocks . . . . .	<b>V4-T2-114</b>
Drawout Cassette . . . . .	<b>V4-T2-115</b>

### Motor Operators

#### Product Description

Eaton’s motor operator mechanism enables local and remote ON, OFF and reset switching of a circuit breaker. The motor operator is mounted on the circuit breaker cover within the dimensions of the circuit breaker.

The robust motor operators offer various voltages to maximize customer flexibility. Standard load transfer switching can be accomplished through the use of two circuit breakers fitted with motor operators and a mechanical interlock.

### Features, Benefits and Functions

The motor operator provides special features for ease of customer use and status indication.

- The motor operator allows the circuit breaker to be opened, closed or reset remotely
- The motor operator contains a motor connected to a cam drive mechanism. The cam drives a slide mechanism to operate the circuit breaker handle
- Internal limit switches and relays are used to control motor operation to prevent overdriving the circuit breaker handle and motor overload conditions
- A key is provided to manually operate the circuit breaker
- A special pull-out locking mechanism provides a method for padlocking the circuit breaker handle in the OFF position
- The locking device will accept three padlock shackles with a maximum diameter of 1/4-inch (6.4 mm) each
- The cover provides visual status of the circuit breaker: ON, OFF or TRIPPED. A PUSH-TO-TRIP button allows the user to manually trip the breaker

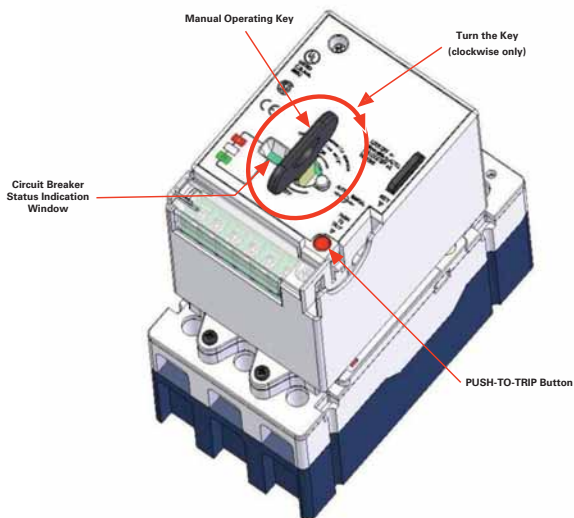

### Standards and Certifications

The motor operators are UL and CSA listed, and CE marked.



### Product Selection

#### Motor Operators

Frame	Voltage	Frequency	Inrush Current	Catalog Number
Series G E-Frame	100–240 Vac	50/60 Hz	1A	<b>MOPEG240C</b>
	100–220 Vdc	DC	1A	<b>MOPEG240C</b>
	24/48 Vdc	DC	3A	<b>MOPEG48D</b>
Series C F-Frame	208–240 Vac	50/60 Hz	1A	<b>MOPFD240C</b>
	110–127 Vac	50/60 Hz	1A	<b>MOPFD120C</b>
	220–250 Vdc	DC	1A	<b>MOPFD240C</b>
	110–125 Vdc	DC	1A	<b>MOPFD120C</b>
Series G J-Frame	24 Vdc	DC	3A	<b>MOPFD24D</b>
	208–240 Vac	50/60 Hz	1A	<b>MOPJG240C</b>
	110–127 Vac	50/60 Hz	1A	<b>MOPJG120C</b>
	220–250 Vdc	DC	1A	<b>MOPJG240C</b>
Series G L-Frame	110–125 Vdc	DC	1A	<b>MOPJG120C</b>
	24 Vdc	DC	3A	<b>MOPJG24D</b>
	208–240 Vac	50/60 Hz	2A	<b>MOPLG240C</b>
	110–127 Vac	50/60 Hz	2A	<b>MOPLG120C</b>
Series G L-Frame	220–250 Vdc	DC	2A	<b>MOPLG240C</b>
	110–125 Vdc	DC	2A	<b>MOPLG120C</b>
	24 Vdc	DC	6A	<b>MOPLG24D</b>

#### LG Breaker with Plug-In Block

2

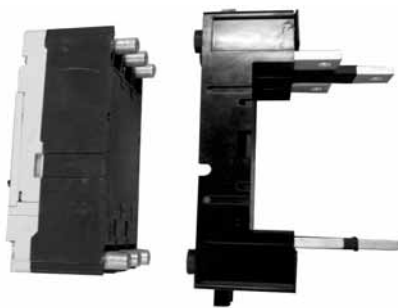

### Contents

<i>Description</i>	<i>Page</i>
EG-Frame (15–125 Amperes) . . . . .	<b>V4-T2-15</b>
JG-Frame (63–250 Amperes) . . . . .	<b>V4-T2-29</b>
LG-Frame (250–630 Amperes) . . . . .	<b>V4-T2-47</b>
NG-Frame (320–1200 Amperes) . . . . .	<b>V4-T2-65</b>
RG-Frame (800–2500 Amperes) . . . . .	<b>V4-T2-74</b>
Motor Circuit Protectors (MCP) . . . . .	<b>V4-T2-85</b>
Motor Protector Circuit Breakers (MPCB) . . . . .	<b>V4-T2-89</b>
30 mA Ground Fault (Earth Leakage) Module . . . . .	<b>V4-T2-92</b>
Current Limiting Circuit Breaker Module . . . . .	<b>V4-T2-96</b>
High Instantaneous Circuit Breaker for Selective Coordination . . . . .	<b>V4-T2-101</b>
Special Features and Accessories . . . . .	<b>V4-T2-104</b>
Motor Operators . . . . .	<b>V4-T2-112</b>
Plug-In Blocks	
Drawout Cassette . . . . .	<b>V4-T2-115</b>

### Plug-In Blocks

#### Product Description

Plug-in adapters simplify installation and front removal of circuit breakers. Plug-ins are available for rear connection applications on three- and four-pole circuit breakers. Trip on drawout interlock kits are included. Stabs for EG, JG and LG plug-ins rotate 90° for flexible installation. Use terminal shields for IP30 protection.

#### Product Selection

##### Plug-In Blocks

Breaker Frame	Number of Poles	Catalog Number
<b>EG-, JG- and LG-Frame Plug-In Blocks</b>		
EG	3	<b>PAD3E</b>
EG	4	<b>PAD4E</b>
JG	3	<b>PAD3J</b>
JG	4	<b>PAD4J</b>
LG	3	<b>PAD3L</b>
LG	4	<b>PAD4L</b>
<b>Trip-On Drawout Interlock Kit ①</b>		
EG	3, 4	<b>PIILEG</b>
JG	3, 4	<b>PIILJG</b>
LG	3, 4	<b>PIILLG</b>
<b>Terminal Shields IP30</b>		
EG	3	<b>EFTS3K</b>
EG	4	<b>EFTS4K</b>
JG	3	<b>FJTS3K</b>
JG	4	<b>FJTS4K</b>
LG	3	<b>LTS3K</b>
LG	4	<b>LTS4K</b>

#### Note

① Included with plug-in block. Trips the breaker when breaker is removed from plug-in block.

**Drawout Cassettes**



**Contents**

<i>Description</i>	<i>Page</i>
EG-Frame (15–125 Amperes) . . . . .	<b>V4-T2-15</b>
JG-Frame (63–250 Amperes) . . . . .	<b>V4-T2-29</b>
LG-Frame (250–630 Amperes) . . . . .	<b>V4-T2-47</b>
NG-Frame (320–1200 Amperes) . . . . .	<b>V4-T2-65</b>
RG-Frame (800–2500 Amperes) . . . . .	<b>V4-T2-74</b>
Motor Circuit Protectors (MCP) . . . . .	<b>V4-T2-85</b>
Motor Protector Circuit Breakers (MPCB). . . . .	<b>V4-T2-89</b>
30 mA Ground Fault (Earth Leakage) Module . . . . .	<b>V4-T2-92</b>
Current Limiting Circuit Breaker Module . . . . .	<b>V4-T2-96</b>
High Instantaneous Circuit Breaker for Selective Coordination . . . . .	<b>V4-T2-101</b>
Special Features and Accessories. . . . .	<b>V4-T2-104</b>
Motor Operators . . . . .	<b>V4-T2-112</b>
Plug-In Blocks . . . . .	<b>V4-T2-114</b>
Drawout Cassette	

**Drawout Cassette**

**Product Description**

The drawout cassette is available for use with JG, LG and NG, three- and four-pole breakers. The cassettes consist of two separate components: the movable mechanism, which attaches to the breaker, and the stationary mechanism, which houses in the cassette. For the JG, LG and NG drawout cassettes, all necessary parts for installation are included in the one catalog number.

**Features**

Features of the drawout cassettes for the JG, LG and NG include:

- Trip on drawout—breaker will trip if it is in the ON position when withdrawn from the cassette
- Secondary terminal block—the drawout cassettes include a secondary terminal block for easier access when wiring low voltage accessories, including shunts and undervoltage releases

The drawout mechanism has three primary positions:

- Connected—the breaker is fully connected to the primary stabs and secondary contacts
- Disconnected—both the primary stabs and the secondary contacts are disconnected
- Withdraw—the breaker can be removed from the cassette

**Product Selection**

**JG Drawout Cassette**



**LG Drawout Cassette**



**JG, LG and NG Drawout Cassettes**

Breaker Frame	Number of Poles	Catalog Number
JG	3	<b>JG3DOM</b>
	4	<b>JG4DOM</b>
LG	3	<b>LG3DOM</b>
	4	<b>LG4DOM</b>
NG	3	<b>NG3DOM</b>
	4	<b>NG4DOM</b>

## Molded Case Circuit Breaker Product Family

2



## Product Overview

Eaton's molded case circuit breakers are designed to provide circuit protection for low voltage distribution systems. They are described by NEMA as, "... a device for closing and interrupting a circuit between separable contacts under both normal and abnormal conditions," and furthermore as, "... a breaker assembled as an integral unit in a supporting and enclosing housing of insulating material." The National Electrical Code (NEC) describes them as, "A device designed to open and close a circuit by non-automatic means, and to open the circuit automatically on a predetermined overload of current, without injury to itself when properly applied within its rating."

So designed, Eaton circuit breakers protect conductors against overloads and conductors and connected apparatus, such as motors and motor starters, against short circuits.

In low voltage distribution systems, there are many varied applications of molded case circuit breakers.

Eaton offers the most comprehensive family of molded case circuit breakers in the industry.

This section of circuit breakers includes:

- Thermal-magnetic trip breakers
- Electronic rms trip breakers
- Molded case switches
- Motor circuit protectors
- Current limiting breakers
- Special application breakers

### Modified Breakers

Eaton breakers can be ordered with internal accessories installed. These modified breakers will be subject to an addition charge.

### Special Calibration

Special non-UL-listed calibrations are available for certain ambient temperatures other than 40 °C and for frequencies other than 50/60 Hz or DC. Reduced interrupting ratings will apply for 400 Hz applications.

## Contents

<i>Description</i>	<i>Page</i>
Standards and Certifications . . . . .	<b>V4-T2-117</b>
Quick Reference . . . . .	<b>V4-T2-118</b>
G-Frame (15–100 Amperes) . . . . .	<b>V4-T2-121</b>
F-Frame (10–225 Amperes) . . . . .	<b>V4-T2-135</b>
J-Frame (70–250 Amperes) . . . . .	<b>V4-T2-153</b>
K-Frame (70–400 Amperes) . . . . .	<b>V4-T2-161</b>
L-Frame (125–600 Amperes) . . . . .	<b>V4-T2-185</b>
M-Frame (300–800 Amperes) . . . . .	<b>V4-T2-211</b>
N-Frame (400–1200 Amperes) . . . . .	<b>V4-T2-222</b>
R-Frame (800–2500 Amperes) . . . . .	<b>V4-T2-237</b>
Motor Circuit Protectors (MCP) . . . . .	<b>V4-T2-256</b>
Motor Protection Circuit Breakers (MPCB) . . . . .	<b>V4-T2-267</b>
Type ELC Current Limiter Attachment (Size 0–4) . . . . .	<b>V4-T2-269</b>
Current Limiting Circuit Breaker Module . . . . .	<b>V4-T2-270</b>
Internal Accessories . . . . .	<b>V4-T2-273</b>
External Accessories . . . . .	<b>V4-T2-304</b>



Learn  
Online



Drawings  
Online

### 50 °C Calibration

Add suffix **V** to catalog Number for complete breaker, listed above, when ordering listed ampere ratings for breakers to be used in 50 °C ambients. (No UL label.)

### Moisture-Fungus Treatment

All circuit breaker cases are molded from glass-polyester which does not support the growth of fungus. Any parts which are susceptible to the growth of fungus will require special treatment.

### Freeze-Tested Circuit Breakers

The circuit breakers may be ordered with freeze testing. This option uses special lubrication and mechanical operation is verified at –40 °C.

### Marine Applications

E- to R-Framed circuit breakers can be supplied to meet the following marine specifications:

- U.S. Coast Guard CFR 46; ABS—American Bureau of Shipping; IEEE 45; DNV; Lloyds; and ABS/NVR

These specifications generally require molded case circuit breakers to be supplied with 50 °C ambient, and plug-in adapter kits. When plug-in adapter kits are used, no terminals need be supplied (switchboard applications).

Circuit breakers can also be supplied to meet UL 489 Supplement SA (Marine use) and UL 489 Supplement SB (Naval Use).

UL 489 Supplement SA applies to vessels over 65 feet (19.8 m) in length. Requirements include 40 °C ambient calibration, special labeling, and no use of aluminum conductors or terminals. (No 50 °C.)

- Suffix H08

Or you can choose to add 50 °C ambient but then there is no "UL" mark.

- Suffix VH08

UL 489 Supplement SB requires partial 50 °C ambient calibration, vibration testing, special nameplating and no use of aluminum conductors or terminals. Eaton chooses to always fully calibrate to 50 °C ambient. ("Naval" labeled per UL, and UL now allows 50 °C label here.)

- Suffix VH09

**Certified Test Reports**

Eaton breakers can be ordered with certified test reports at the time of order entry. Test report documents the thermal and magnetic or electronic tripping characteristics of the individual breaker. Breaker and test report must be ordered together. Add suffix 12 to breaker catalog number and enter separate line item on order for certified test report.

**Standards and Certifications**

Molded case circuit breakers are designed to conform with the following standards:

- Underwriters Laboratories Inc., Standard UL 489, molded case circuit breakers and circuit breaker enclosures
- National Electrical Manufacturers Association (NEMA) Standards Publication No. AB1-1993, molded case circuit breakers
- Australian Standard AS 2184, molded case circuit breakers
- British Standards Institution Standard BS 4752: Part 1, switchgear and control gear Part 1: circuit breakers
- Canadian Standards Association (CSA) Standard C22.2 No. 5, service entrance and branch circuit breakers
- International Electrotechnical Commission Recommendations IEC 60947-2, circuit breakers
- Japanese T-Mark Standard molded case circuit breakers
- South African Bureau of Standards, Standard SABS 156, Standard Specification for molded case circuit breakers
- Swiss Electro-Technical Association Standard SEV 157-1, safety regulations for circuit breakers
- Union Technique de l'Electricite Standard NF C 63-120, low voltage switchgear and control gear circuit breaker requirements
- Verband Deutscher Elektrotechniker (Association of German Electrical Engineers) Standard VDE 0660, low voltage switchgear and control gear, circuit breakers

Conformance with these standards satisfies most local and international codes, assuming user acceptability and simplified application.

Molded case circuit breakers equal or exceed Federal Specification Classification W-C-375b requirements for the particular class associated with the circuit breaker frame being considered.

Open breakers do not have service entrance ratings. Service entrance rating is part of the enclosure.



## Quick Reference

## Industrial Circuit Breakers

2

## G-Frame

Circuit Breaker Type	Continuous Ampere Rating at 40 °C	No. of Poles	Volts		Type of Trip <sup>①</sup>	Federal Specification W-C-375b	UL Listed Interrupting Ratings (rms Symmetrical Amperes)								Page Number
			AC	DC			AC (kA)				DC (kA) <sup>②</sup>				
							120	120/240	240	277	480	600	125 <sup>③</sup>	250	
GHB	15–100	1	120	125	N.I.T.U.	11a	65	—	—	—	—	—	14	—	V4-T2-126
GHB	15–100	2, 3	240	125/250	N.I.T.U.	11a10b, 11b	—	—	65	—	—	—	—	14	V4-T2-126
GHB	15–100	1	277	125	N.I.T.U.	12b, 14b	—	—	—	14	—	—	14	—	V4-T2-126
GHB	15–100	2, 3	480Y/277	125/250	N.I.T.U.	15b	—	—	—	14	14	—	—	14	V4-T2-126
HGHB	15–30	1	277	125	N.I.T.U.	12c, 13a, 13b	65	—	—	25	—	—	14	—	V4-T2-126
GHBS	15–30	1, 2	480Y/277	—	—	—	65	65	—	14	—	—	—	—	V4-T1-34
GBHS	15–20	1, 2	600Y/347	—	N.I.T.U.	—	—	—	—	—	—	10	—	—	V4-T1-34
GDB	15–50	2	480	125/250	N.I.T.U.	—	—	—	—	14	—	—	10	—	V4-T2-124
GDB	15–100	3	480	250	N.I.T.U.	—	—	—	—	14	—	—	10	—	V4-T2-124
GD	15–50	2	480	125/250	N.I.T.U.	13b	—	—	65	—	14	—	—	10	V4-T2-123
GD	15–100	3	480	250	N.I.T.U.	13b	—	—	65	—	22	—	—	10	V4-T2-123
GHC	15–100	1	120	125	N.I.T.U.	12c, 13a	65	—	—	—	—	—	14	—	V4-T2-131
GHC	15–100	2, 3	240	125/250	N.I.T.U.	13b	—	—	65	—	—	—	—	1	V4-T2-131
GHC	15–100	1	277	125	N.I.T.U.	12c, 13a	—	—	—	14	—	—	14	—	V4-T2-131
GHC	15–100	2, 3	480Y/277	125/250	N.I.T.U.	13b	—	—	—	14	14	—	—	14	V4-T2-131
HGHC	15–30	1	277	125	N.I.T.U.	—	65	—	—	25	—	—	14	—	V4-T2-131

## Notes

- ① N.I.T.U. is non-interchangeable trip unit and I.T.U. is interchangeable trip unit.
- ② Two-pole circuit breaker, or two poles of three-pole circuit breaker at 250 Vdc.
- ③ Single-pole breakers can be applied in DC systems up to 70 A.

## F-Frame

Circuit Breaker Type	Continuous Ampere Rating at 40 °C	No. of Poles	Volts		Type of Trip <sup>①</sup>	Federal Specification W-C-375b	UL Listed Interrupting Ratings (rms Symmetrical Amperes)								Page Number
			AC	DC			AC (kA)				DC (kA) <sup>②</sup>				
							120	120/240	240	277	480	600	125	250	
EDB	100–225	2, 3	240	125	N.I.T.U.	—	—	—	22	—	—	—	10	—	V4-T2-135
EDS	100–225	2, 3	240	125	N.I.T.U.	—	—	—	42	—	—	—	10	—	V4-T2-135
ED	15–225	2, 3	240	125	N.I.T.U.	12b	—	—	65	—	—	—	10	—	V4-T2-135
EDH	100–225	2, 3	240	125	N.I.T.U.	14b	—	—	100	—	—	—	10	—	V4-T2-135
EDC	100–225	2, 3	240	125	N.I.T.U.	1	—	—	200	—	—	—	10	—	V4-T2-135
EHD	15–100	1	277	125	N.I.T.U.	13a	—	—	—	14	—	—	10	—	V4-T2-135
EHD	15–100	2, 3	480	250	N.I.T.U.	13b	—	—	18	—	14	—	—	10	V4-T2-135
FDB	15–150	2, 3	600	250	N.I.T.U.	18a	—	—	18	—	14	14	—	10	V4-T2-135
FDB	15–150	4	600	250	N.I.T.U.	③	—	—	18	—	14	14	—	10	V4-T2-135
FD	15–150	1	277	125	N.I.T.U.	13a	—	—	—	35	—	—	10	—	V4-T2-135
FD	15–225	2, 3	600	250	N.I.T.U.	22a	—	—	65	—	35	18	—	10	V4-T2-135
FD	15–225	4	600	250	N.I.T.U.	③	—	—	65	—	35	18	—	10	V4-T2-135
FDE	15–225	3	600	—	N.I.T.U.	—	—	—	65	—	35	18	—	—	V4-T2-135
HFD	15–150	1	277	125	N.I.T.U.	13a	—	—	—	65	—	—	10	—	V4-T2-135
HFD	15–225	2,3	600	250	N.I.T.U.	22a	—	—	100	—	65	25	—	22	V4-T2-135
HFD	15–225	4	600	250	N.I.T.U.	③	—	—	100	—	65	25	—	22	V4-T2-135
HFDE	15–225	3	600	—	N.I.T.U.	—	—	—	100	—	65	25	—	—	V4-T2-135
FDC <sup>④</sup>	15–225	2, 3	600	250	N.I.T.U.	24a	—	—	200	—	100	35	—	22	V4-T2-135
FDC <sup>④</sup>	15–225	4	600	250	N.I.T.U.	③	—	—	200	—	100	35	—	22	V4-T2-135
FDCE <sup>④⑤</sup>	15–225	3	600	—	N.I.T.U.	—	—	—	200	—	100	25	—	—	V4-T2-135

**Notes**

- ① N.I.T.U. is non-interchangeable trip unit and I.T.U. is interchangeable trip unit.  
 ② Two-pole circuit breaker, or two poles of three-pole circuit breaker at 250 Vdc.  
 ③ Not defined in W-C-375b.  
 ④ Current limiting.  
 ⑤ Check with Eaton for availability.

# 2.3

## Molded Case Circuit Breakers

### Series C

2

#### J-Frame

Circuit Breaker Type	Continuous Ampere Rating at 40 °C	No. of Poles	Volts		Type of Trip ①	Federal Specification W-C-375b	UL Listed Interrupting Ratings (rms Symmetrical Amperes)								Page Number
			AC	DC			AC (kA)				DC (kA) ②				
							120	120/240	240	277	480	600	125	250	
JDB	70–250	2, 3	600	250	N.I.T.U.	22a	—	—	65	—	35	18	—	10	V4-T2-156
JD	70–250	2, 3, 4	600	250	I.T.U.	22a	—	—	65	—	35	18	—	10	V4-T2-155
HJD	70–250	2, 3, 4	600	250	I.T.U.	22a	—	—	100	—	65	25	—	22	V4-T2-155
JDC ③	70–250	2, 3, 4	600	250	I.T.U.	22a	—	—	200	—	100	35	—	22	V4-T2-155

#### K-Frame

Circuit Breaker Type	Continuous Ampere Rating at 40 °C	No. of Poles	Volts		Type of Trip ①	Federal Specification W-C-375b	UL Listed Interrupting Ratings (rms Symmetrical Amperes)								Page Number
			AC	DC			AC (kA)				DC (kA) ②				
							120	120/240	240	277	480	600	125	250	
DK	250–400	2, 3	240	250	N.I.T.U.	14b	—	—	65	—	—	—	—	10	V4-T2-167
KDB	100–400	2, 3	600	250	N.I.T.U.	23a	—	—	65	—	35	25	—	10	V4-T2-167
KD	100–400	2, 3, 4	600	250	I.T.U.	23a	—	—	65	—	35	25	—	10	V4-T2-164, V4-T2-165, V4-T2-169, V4-T2-172
CKD	100–400	2, 3, 4	600	250	I.T.U.	23a	—	—	65	—	35	25	—	—	V4-T2-166, V4-T2-175, V4-T2-177
HKD	100–400	2, 3, 4	600	250	I.T.U.	23a	—	—	100	—	65	35	—	22	V4-T2-164, V4-T2-165, V4-T2-169, V4-T2-172
CHKD	100–400	2, 3, 4	600	250	I.T.U.	23a	—	—	100	—	65	35	—	—	V4-T2-166, V4-T2-175, V4-T2-177
KDC ③	100–400	2, 3, 4	600	250	I.T.U.	23a	—	—	200	—	100	65	—	22	V4-T2-164, V4-T2-165, V4-T2-169, V4-T2-172

#### L-Frame

Circuit Breaker Type	Continuous Ampere Rating at 40 °C	No. of Poles	Volts		Type of Trip ①	Federal Specification W-C-375b	UL Listed Interrupting Ratings (rms Symmetrical Amperes)								Page Number
			AC	DC			AC (kA)				DC (kA) ②				
							120	120/240	240	277	480	600	125	250	
LDB	300–600	2, 3	600	250	N.I.T.U.	23a	—	—	65	—	35	25	—	22	V4-T2-190
LD	300–600	2, 3, 4	600	250	I.T.U.	23a	—	—	65	—	35	25	—	22	V4-T2-188, V4-T2-189, V4-T2-194
CLD	300–600	2, 3, 4	600	250	I.T.U.	23a	—	—	65	—	35	25	—	—	V4-T2-190, V4-T2-200
HLD	300–600	2, 3, 4	600	250	I.T.U.	23a	—	—	100	—	65	35	—	25	V4-T2-188, V4-T2-189, V4-T2-194
CHLD	300–600	2, 3, 4	600	250	I.T.U.	23a	—	—	100	—	65	35	—	—	V4-T2-190, V4-T2-200
LDC ③	300–600	2, 3, 4	600	250	I.T.U.	23a	—	—	200	—	100	50	—	30	V4-T2-188, V4-T2-189, V4-T2-196
CLDC ③	300–600	2, 3, 4	600	250	I.T.U.	23a	—	—	200	—	100	50	—	30	V4-T2-190, V4-T2-202

#### M-Frame

Circuit Breaker Type	Continuous Ampere Rating at 40 °C	No. of Poles	Volts		Type of Trip ①	Federal Specification W-C-375b	UL Listed Interrupting Ratings (rms Symmetrical Amperes)								Page Number
			AC	DC			AC (kA)				DC (kA) ②				
							120	120/240	240	277	480	600	125	250	
MDL	300–800	2, 3	600	250	I.T.U.	23a	—	—	65	—	50	25	—	22	V4-T2-213, V4-T2-215
CMDL	300–800	2, 3	600	250	I.T.U.	23a	—	—	65	—	50	25	—	—	V4-T2-215
HMDL	300–800	2, 3	600	250	I.T.U.	23a	—	—	100	—	65	35	—	25	V4-T2-213, V4-T2-215
CHMDL	300–800	2, 3	600	250	I.T.U.	23a	—	—	100	—	65	35	—	—	V4-T2-215

#### Notes

① N.I.T.U. is non-interchangeable trip unit and I.T.U. is interchangeable trip unit.

② Two-pole circuit breaker, or two poles of three-pole circuit breaker at 250 Vdc.

③ Current limiting.

**Molded Case Circuit Breaker Product Family****Contents**

<b>Description</b>	<b>Page</b>
Product Overview . . . . .	<b>V4-T2-116</b>
Standards and Certifications . . . . .	<b>V4-T2-117</b>
Quick Reference . . . . .	<b>V4-T2-118</b>
G-Frame (15–100 Amperes)	
Catalog Number Selection . . . . .	<b>V4-T2-122</b>
Technical Data and Specifications . . . . .	<b>V4-T2-122</b>
F-Frame (10–225 Amperes) . . . . .	<b>V4-T2-135</b>
J-Frame (70–250 Amperes) . . . . .	<b>V4-T2-153</b>
K-Frame (70–400 Amperes) . . . . .	<b>V4-T2-161</b>
L-Frame (125–600 Amperes) . . . . .	<b>V4-T2-185</b>
M-Frame (300–800 Amperes) . . . . .	<b>V4-T2-211</b>
N-Frame (400–1200 Amperes) . . . . .	<b>V4-T2-222</b>
R-Frame (800–2500 Amperes) . . . . .	<b>V4-T2-237</b>
Motor Circuit Protectors (MCP) . . . . .	<b>V4-T2-256</b>
Motor Protection Circuit Breakers (MPCB) . . . . .	<b>V4-T2-267</b>
Type ELC Current Limiter Attachment (Size 0–4) . . . . .	<b>V4-T2-269</b>
Current Limiting Circuit Breaker Module . . . . .	<b>V4-T2-270</b>
Internal Accessories . . . . .	<b>V4-T2-273</b>
External Accessories . . . . .	<b>V4-T2-304</b>

**G-Frame (15–100 Amperes)****Product Description**

- All two- and three-pole circuit breakers are of the common trip type. On all three-phase delta (240 V) Grounded B phase applications, refer to Eaton
- Single-pole circuit breakers, 15 and 20 amperes. Switching duty rated (SWD) for fluorescent lighting applications
- All G-Frame circuit breakers are suitable for reverse feed use
- HACR rated

### Catalog Number Selection

This information is presented only as an aid to understanding catalog numbers. It is not to be used to build catalog numbers for circuit breakers or trip units.

2

#### Circuit Breaker/Frame

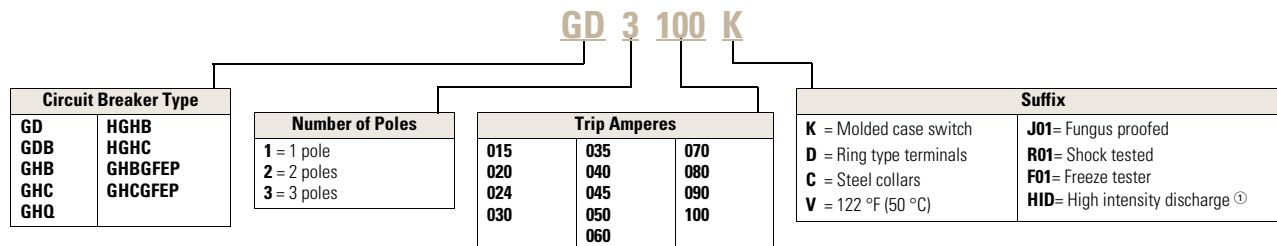

### Technical Data and Specifications

#### UL 489 Interrupting Capacity Ratings

Circuit Breaker Type	Number of Poles	Interrupting Capacity (kA Symmetrical Amperes)						
		Volts AC (50/60 Hz)					Volts DC	
		120	240	277	480	480Y/277	125 ②	250 ③④
GDB	2, 3	—	—	—	14	—	—	10
GD	2	—	65	—	14	—	—	10
GD	3	—	65	—	22	—	—	10
GHQ	—	65	—	14	—	—	—	—
GHB	1	65	—	14	—	—	14	—
GHB	2, 3	—	65	—	—	14	14	—
HGHB	1	65	—	25	—	—	14	—
GHC	1	65	—	14	—	—	14	—
GHC	2, 3	—	65	—	—	14	14	—
HGHC	1	65	—	25	—	—	14	—

#### Terminal Types

For line and load-side. Terminals are UL listed as suitable for wire type and size given below.

#### Terminal Types

Circuit Breaker Amperes	Terminal Type Material	Screw Head Type	Wire Type	AWG Wire Range	Metric Wire Range (mm <sup>2</sup> ) ⑤
<b>Standard</b>					
15–20	Clamp (plated steel)	Slotted	Cu/Al	14–10	2.5–4
25–100	Pressure (aluminum body)	Slotted	Cu/Al	10–1/0	4–50
<b>Optional—GD Only</b>					
15–100	Pressure (steel body)	Slotted	Cu	14–3	—

#### Notes

- ① HID suffix only applies to the GHB and GHC single-pole, 15–20 A circuit breakers.
- ② Single-pole breakers can be applied in DC systems up to 70 A.
- ③ Time constant is 8 milliseconds minimum.
- ④ Two poles of three-pole circuit breaker.
- ⑤ Not UL listed sizes.

Typical G-Frame Circuit Breaker



**Contents**

<i>Description</i>	<i>Page</i>
Product Overview . . . . .	V4-T2-116
Standards and Certifications . . . . .	V4-T2-117
Quick Reference . . . . .	V4-T2-118
G-Frame (15–100 Amperes) . . . . .	V4-T2-121
F-Frame (10–225 Amperes) . . . . .	V4-T2-135
J-Frame (70–250 Amperes) . . . . .	V4-T2-153
K-Frame (70–400 Amperes) . . . . .	V4-T2-161
L-Frame (125–600 Amperes) . . . . .	V4-T2-185
M-Frame (300–800 Amperes) . . . . .	V4-T2-211
N-Frame (400–1200 Amperes) . . . . .	V4-T2-222
R-Frame (800–2500 Amperes) . . . . .	V4-T2-237
Motor Circuit Protectors (MCP) . . . . .	V4-T2-256
Motor Protection Circuit Breakers (MPCB) . . . . .	V4-T2-267
Type ELC Current Limiter Attachment (Size 0–4) . . . . .	V4-T2-269
Current Limiting Circuit Breaker Module . . . . .	V4-T2-270
Internal Accessories . . . . .	V4-T2-273
External Accessories . . . . .	V4-T2-304

**Type GD Thermal-Magnetic Circuit Breakers with Non-Interchangeable Trip Units (15–100 Amperes)**

**Product Description**

- Cable in, cable out
- Includes mounting hardware and BMHE

**Standards and Certifications**

- UL/CSA



**Product Selection**

**Type GD Thermal-Magnetic Circuit Breakers with Non-Interchangeable Trip Units**

Maximum Continuous Ampere Rating at 40 °C	480 Vac Maximum, 250 Vdc		Includes Binding Head Screws and Clamps 10–32 x 0.312
	14 kAIC at 480 Vac	22 kAIC at 480 Vac	
	Includes Line and Load Terminals		
	Two-Pole Catalog Number	Three-Pole Catalog Number	Three-Pole Catalog Number
15	GD2015	GD3015	GD3015D
20	GD2020	GD3020	GD3020D
25	GD2025	GD3025	GD3025D
30	GD2030	GD3030	GD3030D
35	GD2035	GD3035	GD3035D
40	GD2040	GD3040	GD3040D
45	GD2045	GD3045	GD3045D
50	GD2050	GD3050	GD3050D
60	—	GD3060	GD3060D
70	—	GD3070	GD3070D
80	—	GD3080	GD3080D
90	—	GD3090	GD3090D
100	—	GD3100	GD3100D

### Type GDB Thermal-Magnetic Circuit Breakers with Non-Interchangeable Trip Units

Maximum Continuous Ampere Rating at 40 °C	480 Vac Maximum, 250 Vdc 14 kAIC at 480 Vac Includes Line and Load Terminals	
	Two-Pole Catalog Number	Three-Pole Catalog Number
15	GDB2015	GDB3015
20	GDB2020	GDB3020
25	GDB2025	GDB3025
30	GDB2030	GDB3030
35	GDB2035	GDB3035
40	GDB2040	GDB3040
45	GDB2045	GDB3045
50	GDB2050	GDB3050
60	—	GDB3060
70	—	GDB3070
80	—	GDB3080
90	—	GDB3090
100	—	GDB3100

### Type GD Molded Case Switches

#### Type GD Molded Case Switches—Three-Pole

Maximum Continuous Ampere Rating at 40 °C	480 Vac Maximum, 250 Vdc Catalog Number (Includes Line and Load Terminals)
	60
60	GD3060KC <sup>①</sup>
100	GD3100K
100	GD3100KD <sup>②</sup>

#### Notes

<sup>①</sup> Includes line and load steel terminals.

<sup>②</sup> Includes binding head screws and clamps 10–32 x 0.312.

Molded case switches may open above 1300 amperes.

**Dimensions**

Approximate Dimensions in Inches (mm)

**GD-Frame, Three-Pole**

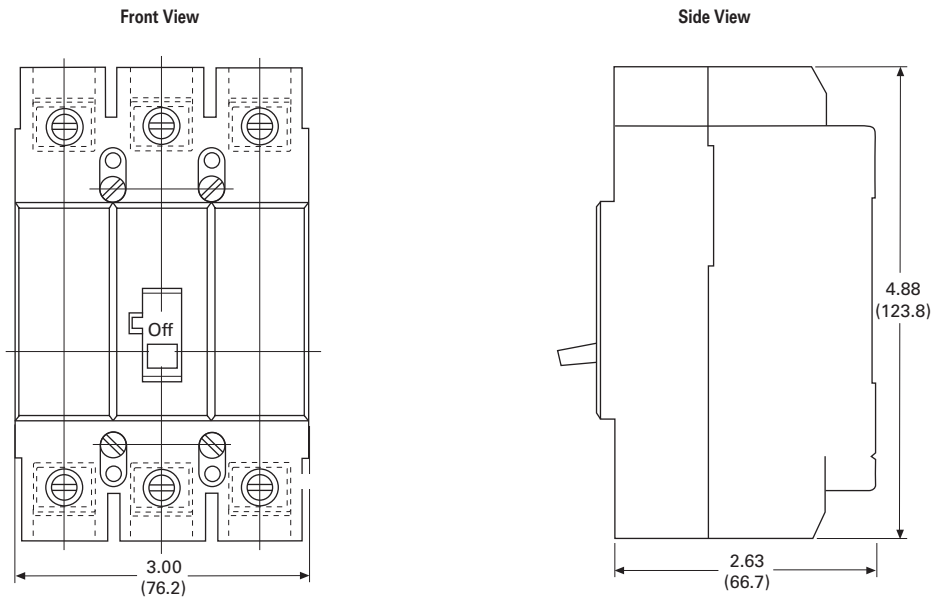

Typical GHB

2



### Contents

<i>Description</i>	<i>Page</i>
Product Overview . . . . .	<b>V4-T2-116</b>
Standards and Certifications . . . . .	<b>V4-T2-117</b>
Quick Reference . . . . .	<b>V4-T2-118</b>
G-Frame (15–100 Amperes) . . . . .	<b>V4-T2-121</b>
F-Frame (10–225 Amperes) . . . . .	<b>V4-T2-135</b>
J-Frame (70–250 Amperes) . . . . .	<b>V4-T2-153</b>
K-Frame (70–400 Amperes) . . . . .	<b>V4-T2-161</b>
L-Frame (125–600 Amperes) . . . . .	<b>V4-T2-185</b>
M-Frame (300–800 Amperes) . . . . .	<b>V4-T2-211</b>
N-Frame (400–1200 Amperes) . . . . .	<b>V4-T2-222</b>
R-Frame (800–2500 Amperes) . . . . .	<b>V4-T2-237</b>
Motor Circuit Protectors (MCP) . . . . .	<b>V4-T2-256</b>
Motor Protection Circuit Breakers (MPCB) . . . . .	<b>V4-T2-267</b>
Type ELC Current Limiter Attachment (Size 0–4) . . . . .	<b>V4-T2-269</b>
Current Limiting Circuit Breaker Module . . . . .	<b>V4-T2-270</b>
Internal Accessories . . . . .	<b>V4-T2-273</b>
External Accessories . . . . .	<b>V4-T2-304</b>

### Types GHB and HGHB Bolt-On Panelboard Circuit Breakers (15–100 Amperes)

#### Standards and Certifications

These breakers meet the requirements of Federal Specification W-C-375b as follows:

- Type GHB, 120 and 240 V:
  - Single-pole: Class 11a
  - Two-, three-pole: Classes 10b, 11b, 12b, 14b, 15b
  - UL/CSA
- Type GHB, 277 and 480Y/277V:
  - Single-pole: Classes 12c, 13a
  - Two-, three-pole: Class 13b
  - Type HGHB 277V
  - Type GHQ 277V



## Product Selection

Typical GHB

Type GHB Thermal-Magnetic Circuit Breakers with Non-Interchangeable Trip Units <sup>①</sup>

Continuous Ampere Rating at 40 °C	277/480 Vac Maximum, 125 Vdc Maximum <sup>②</sup>	277/480 Vac Maximum, 125/250 Vdc Maximum	277/480 Vac Maximum, 125/250 Vdc Maximum <sup>③</sup>
	Single-Pole Catalog Number	Two-Pole Catalog Number	Three-Pole Catalog Number
15	GHB1015 <sup>④⑤</sup>	GHB2015 <sup>④</sup>	GHB3015 <sup>④</sup>
20	GHB1020 <sup>④⑤</sup>	GHB2020 <sup>④</sup>	GHB3020 <sup>④</sup>
25	GHB1025	GHB2025	GHB3025
30	GHB1030	GHB2030	GHB3030
35	GHB1035	GHB2035	GHB3035
40	GHB1040	GHB2040	GHB3040
45	GHB1045	GHB2045	GHB3045
50	GHB1050	GHB2050	GHB3050
60	GHB1060	GHB2060	GHB3060
70	GHB1070	GHB2070	GHB3070
80	GHB1080	GHB2080	GHB3080
90	GHB1090	GHB2090	GHB3090
100	GHB1100	GHB2100	GHB3100

## Type HGHB Thermal-Magnetic Circuit Breakers with Non-Interchangeable Trip Units

Continuous Ampere Rating at 40 °C	277 Vac Maximum, 125 Vdc Maximum Single-Pole Catalog Number
	15
20	HGHB1020 <sup>⑥</sup>
25	HGHB1025
30	HGHB1030

**Notes**

- ① 480Y/277 V, circuit breakers (Type GHB) not suitable for three-phase delta (480 V).
- ② Single-pole breakers can be applied in DC systems from 15 through 70 amperes; 80 through 100 amperes devices are not suitable for DC application.
- ③ Use two outside poles.
- ④ Uses 0.190 (4.83) –32 screw type clamp terminals.
- ⑤ Add suffix HID for High Intensity Discharge (HID) applications. 15 and 20 ampere, single-pole are SWD rated.
- ⑥ 15 and 20 ampere, single-pole are SWD rated.

# 2.3

## Molded Case Circuit Breakers

### Series C

#### Dimensions

Approximate Dimensions in Inches (mm)

2

#### GDB-Frame, Three-Pole

Front View

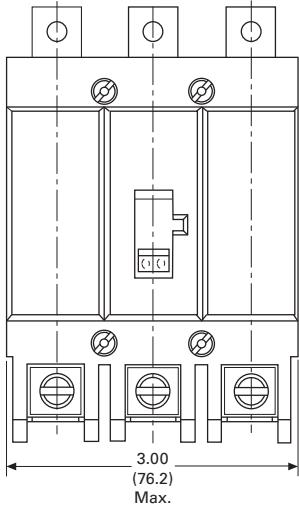

Side View

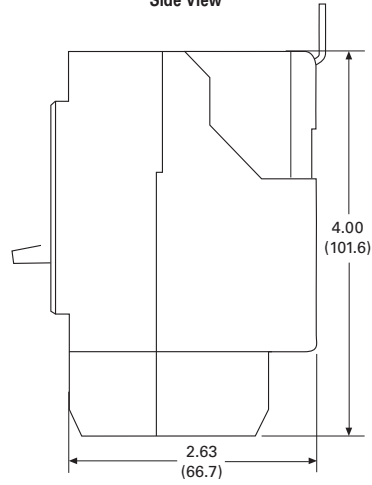

Single-Phase (requires two poles)



**Contents**

<i>Description</i>	<i>Page</i>
Product Overview . . . . .	V4-T2-116
Standards and Certifications . . . . .	V4-T2-117
Quick Reference . . . . .	V4-T2-118
G-Frame (15–100 Amperes) . . . . .	V4-T2-121
F-Frame (10–225 Amperes) . . . . .	V4-T2-135
J-Frame (70–250 Amperes) . . . . .	V4-T2-153
K-Frame (70–400 Amperes) . . . . .	V4-T2-161
L-Frame (125–600 Amperes) . . . . .	V4-T2-185
M-Frame (300–800 Amperes) . . . . .	V4-T2-211
N-Frame (400–1200 Amperes) . . . . .	V4-T2-222
R-Frame (800–2500 Amperes) . . . . .	V4-T2-237
Motor Circuit Protectors (MCP) . . . . .	V4-T2-256
Motor Protection Circuit Breakers (MPCB) . . . . .	V4-T2-267
Type ELC Current Limiter Attachment (Size 0–4) . . . . .	V4-T2-269
Current Limiting Circuit Breaker Module . . . . .	V4-T2-270
Internal Accessories . . . . .	V4-T2-273
External Accessories . . . . .	V4-T2-304

**Type GHBGFEP Bolt-On Panelboard 30 mA Industrial Ground Fault Circuit Protectors (15–100 Amperes)**

**Product Description**

- 15–60 amperes, 277 V, 50/60 Hz
- Operational voltage 240 V to 305 V

**Standards and Certifications**

These circuit breakers meet the requirements of UL 489 and UL 1053.



**Product Selection**

**Type GHBGFEP Bolt-On Panelboard 30 mA Industrial Ground Fault Circuit Protectors with Non-Interchangeable Trip Units**

Continuous Ampere Rating at 40 °C	Single-Phase (Requires Two Poles) 277 Vac, 30 mA Catalog Number
15	GHBGFEP1015
20	GHBGFEP1020
30	GHBGFEP1030
40	GHBGFEP1040
50	GHBGFEP1050
60	GHBGFEP1060

**Technical Data and Specifications**

**Interrupting Capacity Ratings**

Circuit Breaker Type	Number of Poles	Interrupting Capacity (Symmetrical Amperes) 277 Vac (50/60 Hz)
GHBGFEP	1	14,000

# 2.3

## Molded Case Circuit Breakers

### Series C

#### Dimensions

Approximate Dimensions in Inches (mm)

2

#### GHB-Frame, Three-Pole

Front View

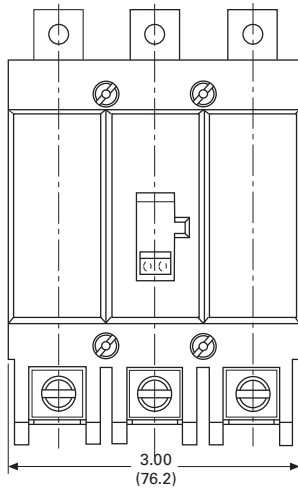

Side View

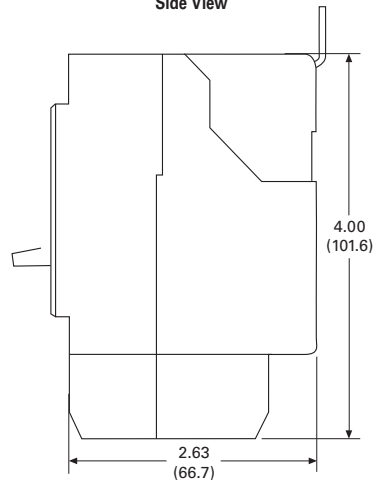

Typical GHC



## Contents

### Description

	<i>Page</i>
Product Overview . . . . .	<b>V4-T2-116</b>
Standards and Certifications . . . . .	<b>V4-T2-117</b>
Quick Reference . . . . .	<b>V4-T2-118</b>
G-Frame (15–100 Amperes) . . . . .	<b>V4-T2-121</b>
F-Frame (10–225 Amperes) . . . . .	<b>V4-T2-135</b>
J-Frame (70–250 Amperes) . . . . .	<b>V4-T2-153</b>
K-Frame (70–400 Amperes) . . . . .	<b>V4-T2-161</b>
L-Frame (125–600 Amperes) . . . . .	<b>V4-T2-185</b>
M-Frame (300–800 Amperes) . . . . .	<b>V4-T2-211</b>
N-Frame (400–1200 Amperes) . . . . .	<b>V4-T2-222</b>
R-Frame (800–2500 Amperes) . . . . .	<b>V4-T2-237</b>
Motor Circuit Protectors (MCP) . . . . .	<b>V4-T2-256</b>
Motor Protection Circuit Breakers (MPCB) . . . . .	<b>V4-T2-267</b>
Type ELC Current Limiter Attachment (Size 0–4) . . . . .	<b>V4-T2-269</b>
Current Limiting Circuit Breaker Module . . . . .	<b>V4-T2-270</b>
Internal Accessories . . . . .	<b>V4-T2-273</b>
External Accessories . . . . .	<b>V4-T2-304</b>

## Types GHC and HGHC Circuit Breakers (15–100 Amperes)

### Product Description

- 15–100 amperes
- 120, 240, 277, 480Y/277V, 50/60 Hz, 125, 125/250 Vdc
- Single-, two- and three-pole
- Cable in, cable out
- Does not include mounting hardware

### Standards and Certifications

These breakers meet the requirements of Federal Specification W-C-37b as follows:

- Type GHC, 277 and 480Y/277V:
  - Single-pole: Classes 12c, 13a
  - Two-, three-pole: Class 13b
  - UL/CSA



## Product Selection

## 2

## Type GHC Thermal-Magnetic Circuit Breakers with Non-Interchangeable Trip Units

Continuous Ampere Rating at 40 °C	277 Vac Maximum, 125 Vdc Maximum <sup>①</sup>	480Y/277 Vac Maximum, 125/250 Vdc Maximum	480Y/277 Vac Maximum, 125/250 Vdc Maximum <sup>②</sup>
	Single-Pole Catalog Number	Two-Pole Catalog Number	Three-Pole Catalog Number
15	GHC1015 <sup>③④</sup>	GHC2015 <sup>③</sup>	GHC3015 <sup>③</sup>
20	GHC1020 <sup>③④</sup>	GHC2020 <sup>③</sup>	GHC3020 <sup>③</sup>
25	GHC1025	GHC2025	GHC3025
30	GHC1030	GHC2030	GHC3030
35	GHC1035	GHC2035	GHC3035
40	GHC1040	GHC2040	GHC3040
45	GHC1045	GHC2045	GHC3045
50	GHC1050	GHC2050	GHC3050
60	GHC1060	GHC2060	GHC3060
70	GHC1070	GHC2070	GHC3070
80	GHC1080	GHC2080	GHC3080
90	GHC1090	GHC2090	GHC3090
100	GHC1100	GHC2100	GHC3100

## Type HGHC Thermal-Magnetic Circuit Breakers with Non-Interchangeable Trip Units

Continuous Ampere Rating at 40 °C	277 Vac Maximum, 125 Vdc Maximum
	Single-Pole Catalog Number
15	HGHC1015 <sup>⑤</sup>
20	HGHC1020 <sup>⑤</sup>
25	HGHC1025
30	HGHC1030

**Notes**

- ① 15 through 70 ampere circuit breakers only.
- ② Single-pole breakers can be applied in DC systems from 15 through 70 ampere; 80 through 100 ampere devices are not suitable for DC application.
- ③ Uses 0.190–32 screw type clamp terminals.
- ④ Add suffix HID for High Intensity Discharge (HID) applications. 15 and 20 ampere, single-pole are SWD rated.
- ⑤ 15 and 20 ampere, single-pole are SWD rated.

Single-Phase (requires two-pole spaces)



**Contents**

<i>Description</i>	<i>Page</i>
Product Overview . . . . .	V4-T2-116
Standards and Certifications . . . . .	V4-T2-117
Quick Reference . . . . .	V4-T2-118
G-Frame (15–100 Amperes) . . . . .	V4-T2-121
F-Frame (10–225 Amperes) . . . . .	V4-T2-135
J-Frame (70–250 Amperes) . . . . .	V4-T2-153
K-Frame (70–400 Amperes) . . . . .	V4-T2-161
L-Frame (125–600 Amperes) . . . . .	V4-T2-185
M-Frame (300–800 Amperes) . . . . .	V4-T2-211
N-Frame (400–1200 Amperes) . . . . .	V4-T2-222
R-Frame (800–2500 Amperes) . . . . .	V4-T2-237
Motor Circuit Protectors (MCP) . . . . .	V4-T2-256
Motor Protection Circuit Breakers (MPCB) . . . . .	V4-T2-267
Type ELC Current Limiter Attachment (Size 0–4) . . . . .	V4-T2-269
Current Limiting Circuit Breaker Module . . . . .	V4-T2-270
Internal Accessories . . . . .	V4-T2-273
External Accessories . . . . .	V4-T2-304

**Type GHCGFEP Cable-In/Cable-Out 30 mA Industrial Ground Fault Circuit Protectors (15–100 Amperes)**

**Product Description**

- 15–60 amperes, 277 V, 50/60 Hz
- Operational voltage 240–305 V

**Standards and Certifications**

These circuit breakers meet the requirements of UL 489 and UL 1053.



**Product Selection**

**Type GHCGFEP 30 mA Industrial Ground Fault Circuit Protectors with Non-Interchangeable Trip Units**

Continuous Ampere Rating at 40 °C	Single-Phase (Requires Two Poles) 277V, 30 mA
	Catalog Number
15	GHCGFEP1015
20	GHCGFEP1020
30	GHCGFEP1030
40	GHCGFEP1040
50	GHCGFEP1050
60	GHCGFEP1060

**Technical Data and Specifications**

**Interrupting Capacity Ratings**

Circuit Breaker Type	Number of Poles	Interrupting Capacity (Symmetrical Amperes)
		277 Vac (50/60 Hz)
GHCGFEP	1	14,000

#### Special Purpose Circuit Breakers

2



#### Contents

<i>Description</i>	<i>Page</i>
Product Overview . . . . .	V4-T2-116
Standards and Certifications . . . . .	V4-T2-117
Quick Reference . . . . .	V4-T2-118
G-Frame (15–100 Amperes) . . . . .	V4-T2-121
F-Frame (10–225 Amperes) . . . . .	V4-T2-135
J-Frame (70–250 Amperes) . . . . .	V4-T2-153
K-Frame (70–400 Amperes) . . . . .	V4-T2-161
L-Frame (125–600 Amperes) . . . . .	V4-T2-185
M-Frame (300–800 Amperes) . . . . .	V4-T2-211
N-Frame (400–1200 Amperes) . . . . .	V4-T2-222
R-Frame (800–2500 Amperes) . . . . .	V4-T2-237
Motor Circuit Protectors (MCP) . . . . .	V4-T2-256
Motor Protection Circuit Breakers (MPCB) . . . . .	V4-T2-267
Type ELC Current Limiter Attachment (Size 0–4) . . . . .	V4-T2-269
Current Limiting Circuit Breaker Module . . . . .	V4-T2-270
Internal Accessories . . . . .	V4-T2-273
External Accessories . . . . .	V4-T2-304

### Special Purpose GHC Circuit Breakers (15–100 Amperes)

#### Product Description

Eaton’s Type GHC circuit breakers have binding head screw-type terminals on line and load side. These circuit breakers with screw-type terminals (0.190–32) will be marked “Special purpose breaker not for general use.” To order this special breaker, use the catalog number from the tables on this page.

#### Product Selection

#### Type GHC Thermal-Magnetic Circuit Breakers with Non-Interchangeable Trip Units

Continuous Ampere Rating at 40 °C	277 Vac Maximum, 125 Vdc Maximum ①	480Y/277 Vac Maximum, 125/250 Vdc Maximum	480Y/277 Vac Maximum, 125/250 Vdc Maximum ②
	Single-Pole Catalog Number	Two-Pole Catalog Number	Three-Pole Catalog Number
25	GHC1025D	GHC2025D	GHC3025D
30	GHC1030D	GHC2030D	GHC3030D
35	GHC1035D	GHC2035D	GHC3035D
40	GHC1040D	GHC2040D	GHC3040D
45	GHC1045D	GHC2045D	GHC3045D
50	GHC1050D	GHC2050D	GHC3050D
60	GHC1060D	GHC2060D	GHC3060D
70	GHC1070D	GHC2070D	GHC3070D
80	GHC1080D	GHC2080D	GHC3080D
90	GHC1090D	GHC2090D	GHC3090D
100	GHC1100D	GHC2100D	GHC3100D

#### Type GHB and GHC Thermal-Magnetic Circuit Breakers with Non-Interchangeable Trip Units for HID Lighting Applications

Type	Continuous Ampere Rating at 40 °C	277 Vac Maximum Single-Pole Catalog Number
Cable-in	15	GHC1015HID
	20	GHC1020HID
Bolt-on	15	GHB1015HID
	20	GHB1020HID

#### Notes

- ① Single-pole breakers can be applied in DC systems from 15 through 70 amperes; 80 through 100 amperes devices are not suitable for DC application.
- ② Use two outside poles.

Typical F-Frame Breaker  
F-Frame Breaker with Electronic Trip Unit



## Contents

### Description

	<i>Page</i>
Product Overview . . . . .	<b>V4-T2-116</b>
Standards and Certifications . . . . .	<b>V4-T2-117</b>
Quick Reference . . . . .	<b>V4-T2-118</b>
G-Frame (15–100 Amperes) . . . . .	<b>V4-T2-121</b>
F-Frame (10–225 Amperes)	
Catalog Number Selection . . . . .	<b>V4-T2-136</b>
Product Selection . . . . .	<b>V4-T2-138</b>
Accessories . . . . .	<b>V4-T2-149</b>
Technical Data and Specifications . . . . .	<b>V4-T2-150</b>
Dimensions and Weights . . . . .	<b>V4-T2-152</b>
J-Frame (70–250 Amperes) . . . . .	<b>V4-T2-153</b>
K-Frame (70–400 Amperes) . . . . .	<b>V4-T2-161</b>
L-Frame (125–600 Amperes) . . . . .	<b>V4-T2-185</b>
M-Frame (300–800 Amperes) . . . . .	<b>V4-T2-211</b>
N-Frame (400–1200 Amperes) . . . . .	<b>V4-T2-222</b>
R-Frame (800–2500 Amperes) . . . . .	<b>V4-T2-237</b>
Motor Circuit Protectors (MCP) . . . . .	<b>V4-T2-256</b>
Motor Protection Circuit Breakers (MPCB) . . . . .	<b>V4-T2-267</b>
Type ELC Current Limiter Attachment (Size 0–4) . . . . .	<b>V4-T2-269</b>
Current Limiting Circuit Breaker Module . . . . .	<b>V4-T2-270</b>
Internal Accessories . . . . .	<b>V4-T2-273</b>
External Accessories . . . . .	<b>V4-T2-304</b>

## F-Frame (10–225 Amperes)

### Product Description

- All Eaton's F-Frame circuit breakers are HACR rated
- All circuit breakers 10 through 30 amperes are suitable for HID (high intensity discharge) use
- All F-Frame circuit breakers are suitable for reverse feed use

# 2.3

## Molded Case Circuit Breakers

### Series C

#### Catalog Number Selection

This information is presented only as an aid to understanding catalog numbers. It is not to be used to build catalog numbers for circuit breakers or trip units.

2

#### FD-Frame Circuit Breakers with Thermal-Magnetic Trip Unit Technology

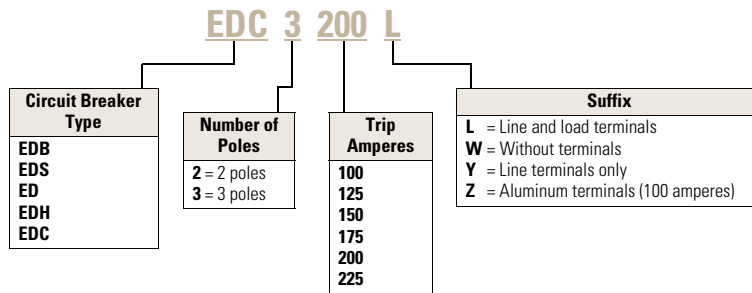
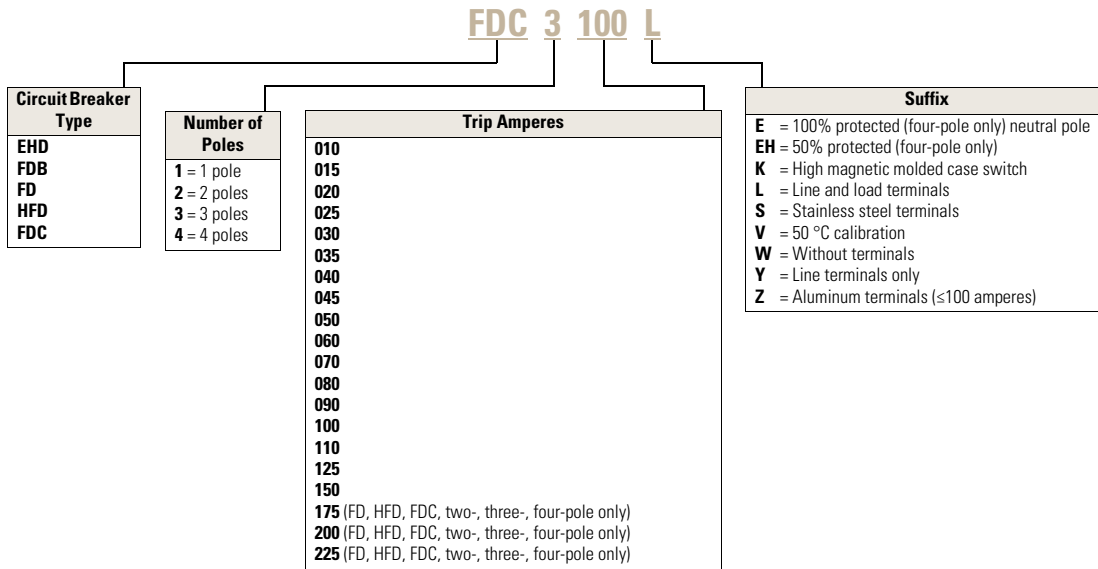

This information is presented only as an aid to understanding catalog numbers. It is not to be used to build catalog numbers for circuit breakers or trip units.

### FD-Frame Circuit Breakers with 210+ Electronic Trip Unit Technology

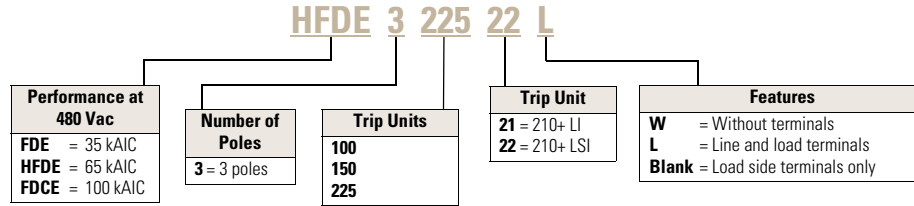

### FD-Frame Circuit Breakers with 310+ Electronic Trip Unit Technology

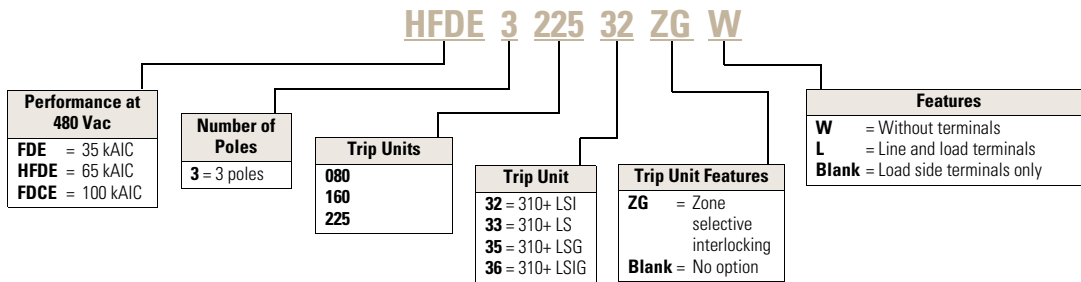

## Product Selection

## 2

## Type ED Thermal-Magnetic Circuit Breakers with Non-Interchangeable Trip Units Suitable for Reverse Feed

240 Vac Maximum, 125 Vdc  
(Includes Terminals on Load End Only)  
65 kAIC at 240 Vac

Maximum Continuous Ampere Rating at 40 °C	Two-Pole Catalog Number	Three-Pole Catalog Number
15	ED2015	ED3015
20	ED2020	ED3020
25	ED2025	ED3025
30	ED2030	ED3030
35	ED2035	ED3035
40	ED2040	ED3040
50	ED2050	ED3050
60	ED2060	ED3060
100	ED2100	ED3100
125	ED2125	ED3125
150	ED2150	ED3150
175	ED2175	ED3175
200	ED2200	ED3200
225	ED2225	ED3225

## Type EDH Thermal-Magnetic Circuit Breakers with Non-Interchangeable Trip Units Suitable for Reverse Feed

240 Vac Maximum, 125 Vdc  
(Includes Terminals on Load End Only)  
100 kAIC at 240 Vac

Maximum Continuous Ampere Rating at 40 °C	Two-Pole Catalog Number	Three-Pole Catalog Number
15	—	—
20	—	—
25	—	—
30	—	—
35	—	—
40	—	—
50	—	—
60	—	—
100	EDH2100	EDH3100
125	EDH2125	EDH3125
150	EDH2150	EDH3150
175	EDH2175	EDH3175
200	EDH2200	EDH3200
225	EDH2225	EDH3225

### Type EDC Thermal-Magnetic Circuit Breakers with Non-Interchangeable Trip Units Suitable for Reverse Feed

Maximum Continuous Ampere Rating at 40 °C	240 Vac Maximum, 125 Vdc (Includes Terminals on Load End Only) 200 kAIC at 240 Vac	
	Two-Pole Catalog Number	Three-Pole Catalog Number
15	—	—
20	—	—
25	—	—
30	—	—
35	—	—
40	—	—
50	—	—
60	—	—
100	EDC2100	EDC3100
125	EDC2125	EDC3125
150	EDC2150	EDC3150
175	EDC2175	EDC3175
200	EDC2200	EDC3200
225	EDC2225	EDC3225

### Type EDB Thermal-Magnetic Circuit Breakers with Non-Interchangeable Trip Units Suitable for Reverse Feed

Maximum Continuous Ampere Rating at 40 °C	240 Vac Maximum, 125 Vdc (Includes Terminals on Load End Only) 22 kAIC at 240 Vac	
	Two-Pole Catalog Number	Three-Pole Catalog Number
100	EDB2100	EDB3100
110	EDB2110	EDB3110
125	EDB2125	EDB3125
150	EDB2150	EDB3150
175	EDB2175	EDB3175
200	EDB2200	EDB3200
225	EDB2225	EDB3225

### Type EDS Thermal-Magnetic Circuit Breakers with Non-Interchangeable Trip Units Suitable for Reverse Feed

Maximum Continuous Ampere Rating at 40 °C	240 Vac Maximum, 125 Vdc (Includes Terminals on Load End Only) 42 kAIC at 240 Vac	
	Two-Pole Catalog Number	Three-Pole Catalog Number
100	EDS2100	EDS3100
110	EDS2110	EDS3110
125	EDS2125	EDS3125
150	EDS2150	EDS3150
175	EDS2175	EDS3175
200	EDS2200	EDS3200
225	EDS2225	EDS3225

### Type EHD Thermal-Magnetic Circuit Breakers with Non-Interchangeable Trip Units (Includes Terminals on Load End Only)

Maximum Continuous Ampere Rating at 40 °C	277 Vac Maximum, 125 Vdc 14 kAIC at 277 Vac Single-Pole	480 Vac Maximum, 250 Vdc 14 kAIC at 480 Vac Two-Pole	Three-Pole
	Catalog Number	Catalog Number	Catalog Number
10 <sup>①</sup>	EHD1010	EHD2010	EHD3010
15	EHD1015 <sup>②</sup>	EHD2015	EHD3015
20	EHD1020 <sup>②</sup>	EHD2020	EHD3020
25	EHD1025	EHD2025	EHD3025
30	EHD1030	EHD2030	EHD3030
35	EHD1035	EHD2035	EHD3035
40	EHD1040	EHD2040	EHD3040
45	EHD1045	EHD2045	EHD3045
50	EHD1050	EHD2050	EHD3050
60	EHD1060	EHD2060	EHD3060
70	EHD1070	EHD2070	EHD3070
80	EHD1080	EHD2080	EHD3080
90	EHD1090	EHD2090	EHD3090
100	EHD1100	EHD2100	EHD3100

#### Notes

- <sup>①</sup> Not UL listed. 5 kAIC interrupting rating.
- <sup>②</sup> UL listed for SWD applications, see NEC Article 240.83(d).

**Type FDB Thermal-Magnetic Circuit Breakers with Non-Interchangeable Trip Units  
(Includes Terminals on Load End Only)**

Maximum Continuous Ampere Rating at 40 °C	600 Vac Maximum, 250 Vdc 14 kAIC at 600 Vac		
	Two-Pole Catalog Number	Three-Pole Catalog Number	Four-Pole Catalog Number
10 ①	FDB2010	FDB3010	FDB4010
15	FDB2015	FDB3015	FDB4015
20	FDB2020	FDB3020	FDB4020
25	FDB2025	FDB3025	FDB4025
30	FDB2030	FDB3030	FDB4030
35	FDB2035	FDB3035	FDB4035
40	FDB2040	FDB3040	FDB4040
45	FDB2045	FDB3045	FDB4045
50	FDB2050	FDB3050	FDB4050
60	FDB2060	FDB3060	FDB4060
70	FDB2070	FDB3070	FDB4070
80	FDB2080	FDB3080	FDB4080
90	FDB2090	FDB3090	FDB4090
100	FDB2100	FDB3100	FDB4100
110	FDB2110	FDB3110	FDB4110
125	FDB2125	FDB3125	FDB4125
150	FDB2150	FDB3150	FDB4150

**Notes**

- ① Not UL listed. 5 kAIC interrupting rating.
- ② UL listed for SWD applications, see NEC Article 240.83(d).

**Type FD Thermal-Magnetic Circuit Breakers with Non-Interchangeable Trip Units  
(Includes Terminals on Load End Only)**

2

Maximum Continuous Ampere Rating at 40 °C	277 Vac Maximum, 125 Vdc 35 kAIC at 277 Vac	600 Vac Maximum, 250 Vdc 35 kAIC at 480 Vac		
	Single-Pole Catalog Number	Two-Pole Catalog Number	Three-Pole Catalog Number	Four-Pole Catalog Number
10 ①	FD1010	—	—	—
15	FD1015 ②	FD2015	FD3015	FD4015
20	FD1020 ②	FD2020	FD3020	FD4020
25	FD1025	FD2025	FD3025	FD4025
30	FD1030	FD2030	FD3030	FD4030
35	FD1035	FD2035	FD3035	FD4035
40	FD1040	FD2040	FD3040	FD4040
45	FD1045	FD2045	FD3045	FD4045
50	FD1050	FD2050	FD3050	FD4050
60	FD1060	FD2060	FD3060	FD4060
70	FD1070	FD2070	FD3070	FD4070
80	FD1080	FD2080	FD3080	FD4080
90	FD1090	FD2090	FD3090	FD4090
100	FD1100	FD2100	FD3100	FD4100
110	FD1110	FD2110	FD3110	FD4110
125	FD1125	FD2125	FD3125	FD4125
150	FD1150	FD2150	FD3150	FD4150
175	—	FD2175	FD3175	FD4175
200	—	FD2200	FD3200	FD4200
225	—	FD2225	FD3225	FD4225

**Notes**

① Not UL listed. 5 kAIC interrupting rating.

② UL listed for SWD applications, see NEC Article 240.83(d).

**Type HFD Thermal-Magnetic Circuit Breakers with Non-Interchangeable Trip Units  
(Includes Terminals on Load End Only)**

Maximum Continuous Ampere Rating at 40 °C	277 Vac Maximum, 125 Vdc 65 kAIC at 277 Vac	600 Vac Maximum, 250 Vdc 65 kAIC at 480 Vac		
	Single-Pole Catalog Number	Two-Pole Catalog Number	Three-Pole Catalog Number	Four-Pole Catalog Number
15	HFD1015 ①	HFD2015	HFD3015	HFD4015
20	HFD1020 ①	HFD2020	HFD3020	HFD4020
25	HFD1025	HFD2025	HFD3025	HFD4025
30	HFD1030	HFD2030	HFD3030	HFD4030
35	HFD1035	HFD2035	HFD3035	HFD4035
40	HFD1040	HFD2040	HFD3040	HFD4040
45	HFD1045	HFD2045	HFD3045	HFD4045
50	HFD1050	HFD2050	HFD3050	HFD4050
60	HFD1060	HFD2060	HFD3060	HFD4060
70	HFD1070	HFD2070	HFD3070	HFD4070
80	HFD1080	HFD2080	HFD3080	HFD4080
90	HFD1090	HFD2090	HFD3090	HFD4090
100	HFD1100	HFD2100	HFD3100	HFD4100
110	HFD1110	HFD2110	HFD3110	HFD4110
125	HFD1125	HFD2125	HFD3125	HFD4125
150	HFD1150	HFD2150	HFD3150	HFD4150
175	—	HFD2175	HFD3175	HFD4175
200	—	HFD2200	HFD3200	HFD4200
225	—	HFD2225	HFD3225	HFD4225

**Note**

① UL listed for SWD applications, see NEC Article 240.83(d).

**Type FDC Thermal-Magnetic Circuit Breakers with Non-Interchangeable Trip Units  
(Includes Terminals on Load End Only)**

2

Maximum Continuous Ampere Rating at 40 °C	600 Vac Maximum, 250 Vdc 100 kAIC at 480 Vac		
	Two-Pole Catalog Number	Three-Pole Catalog Number	Four-Pole Catalog Number
15	FDC2015	FDC3015	FDC4015
20	FDC2020	FDC3020	FDC4020
25	FDC2025	FDC3025	FDC4025
30	FDC2030	FDC3030	FDC4030
35	FDC2035	FDC3035	FDC4035
40	FDC2040	FDC3040	FDC4040
45	FDC2045	FDC3045	FDC4045
50	FDC2050	FDC3050	FDC4050
60	FDC2060	FDC3060	FDC4060
70	FDC2070	FDC3070	FDC4070
80	FDC2080	FDC3080	FDC4080
90	FDC2090	FDC3090	FDC4090
100	FDC2100	FDC3100	FDC4100
110	FDC2110	FDC3110	FDC4110
125	FDC2125	FDC3125	FDC4125
150	FDC215	FDC3150	FDC4150
175	FDC2175	FDC3175	FDC4175
200	FDC2200	FDC3200	FDC4200
225	FDC2225	FDC3225	FDC4225

**Types FDE, HFDE and FDCE 310+ Electronic Circuit Breakers with Non-Interchangeable Trip Units**See 310+ adjustability specifications on **Page V4-T2-151**.

Maximum Ampere Rating	Digitrip RMS 310+ Trip Unit Only		LSG Adjustable Short Time Pickup with I <sup>2</sup> t Short Delay and Ground Fault Protection	LSIG Independently Adjustable Short Time Pickup and Ground Fault Protection	Neutral CT for LSG and LSIG Catalog Number
	Standard LS Adjustable Short Time Pickup with I <sup>2</sup> t Short Delay Ramp Catalog Number	Optional LSI Independently Adjustable Short Time Pickup and Delay			
<b>35 kAIC at 480 Vac / 18 kAIC at 600 Vac</b>					
80	FDE308033	FDE308032	FDE308035	FDE308036	CTF080
160	FDE316033	FDE316032	FDE316035	FDE316036	CTF160
225	FDE322533	FDE322532	FDE322535	FDE322536	CTF225
<b>65 kAIC at 480 Vac / 25 kAIC at 600 Vac</b>					
80	HFDE308033	HFDE308032	HFDE308035	HFDE308036	CTF080
160	HFDE316033	HFDE316032	HFDE316035	HFDE316036	CTF160
225	HFDE322533	HFDE322532	HFDE322535	HFDE322536	CTF225
<b>100 kAIC at 480 Vac / 25 kAIC at 600 Vac</b>					
80	FDCE308033	FDCE308032	FDCE308035	FDCE308036	CTF080
160	FDCE316033	FDCE316032	FDCE316035	FDCE316036	CTF160
225	FDCE322533	FDCE322532	FDCE322535	FDCE322536	CTF225

**Types FDE, HFDE, and FDCE 210+ Electronic Circuit Breakers with Non-Interchangeable Trip Units**

Maximum Ampere Rating	Digitrip RMS 210+ Trip Unit Only	
	Standard LI Adjustable Instantaneous Catalog Number	Optional LSI Adjustable Short Time Pickup and Delay Catalog Number
<b>35 kAIC at 480 Vac / 18 kAIC at 600 Vac</b>		
100	FDE310021	FDE310022
150	FDE315021	①
225	FDE322521	FDE322522
<b>65 kAIC at 480 Vac / 25 kAIC at 600 Vac</b>		
100	HFDE310021	HFDE310022
150	HFDE315021	①
225	HFDE322521	HFDE322522
<b>100 kAIC at 480 Vac / 25 kAIC at 600 Vac ②</b>		
100	FDCE310021	FDCE310022
150	FDCE315021	①
225	FDCE322521	FDCE322522

**210+ Trip Electronic Trip Units Amperage Settings**

Circuit Breaker Type	Frame	Ratings
FDE, HFDE, FDCE	225	100, 110, 125, 150, 175, 200, 225
FDE, HFDE, FDCE	150	70, 80, 90, 100, 110, 125, 150
FDE, HFDE, FDCE	100	40, 50, 60, 70, 80, 90, 100

**FDE 310+ Electronic Breaker with Zone Selective Interlocking**

Ampere Rating	LSI w/ZSI Catalog Number	LSIG w/ZSI Catalog Number
<b>35 kAIC at 480 Vac / 18 kAIC at 600 Vac</b>		
80	FDE308032ZG	FDE308036ZG
160	FDE316032ZG	FDE316036ZG
225	FDE322532ZG	FDE322536ZG
<b>65 kAIC at 480 Vac / 25 kAIC at 600 Vac</b>		
80	HFDE308032ZG	HFDE308036ZG
160	HFDE316032ZG	HFDE316036ZG
225	HFDE322532ZG	HFDE322536ZG
<b>100 kAIC at 480 Vac / 25 kAIC at 600 Vac</b>		
80	FDCE308032ZG	FDCE308036ZG
160	FDCE316032ZG	FDCE316036ZG
225	FDCE322532ZG	FDCE322536ZG

**Digitrip 310+ Electronic Trip Units Amperage Settings**

Circuit Breaker Type	Frame	Ratings
FDE, HFDE, FDCE	225	100, 110, 125, 150, 160, 175, 200, 225
FDE, HFDE, FDCE	160	60, 70, 80, 90, 100, 125, 150, 160
FDE, HFDE, FDCE	80	15, 20, 30, 40, 50, 60, 70, 80

**Notes**

① For 210+ trip unit, 150 A not available with LSI trip unit; entire range is covered by 100 A and 225 A frames.

② Contact the product line for availability.

**Molded Case Switches**

Eaton's molded case switches are used as compact switches in applications requiring high current switching capabilities. Molded case switches are constructed of circuit breaker

components and are of the high instantaneous automatic type. Molded case switches are listed in accordance with Underwriters Laboratories Standard UL 489.

**Molded Case Switches**

Maximum Continuous Ampere Rating at 40 °C	Complete Circuit Breaker with Load Side Terminals Only		
	480 Vac Maximum, 250 Vdc Catalog Number	600 Vac Maximum, 250 Vdc Catalog Number	
<b>Two-Pole</b>			
100	EHD2100K	FD2100K	HFD2100K
150	—	FD2150K	HFD2150K
225	—	FD2225K	HFD2225K
<b>Three-Pole</b>			
100	EHD3100K	FD3100K	HFD3100K
150	—	FD3150K	HFD3150K
225	—	FD3225K	HFD3225K
<b>Four-Pole</b>			
100	—	FD4100K	HFD4100K
150	—	FD4150K	HFD4150K
225	—	FD4225K	HFD4225K

**Note**

Molded case switches will open above 1800 amperes.

## Accessories Selection Guide and Ordering Information

### Line and Load Terminals

Line and load terminals provide wire connecting capabilities for specific ranges of continuous current ratings and wire types. Except as noted, terminals comply with Underwriters Laboratories Standards UL 486A and UL 486B. Unless otherwise specified, F-Frame circuit breakers are factory equipped with load terminals only.

### Ordering Information

F-Frame circuit breakers and molded case switches have load terminals only as standard equipment. When standard line-end terminals (same as standard load-end terminals) are required, add Suffix **L** to the circuit breaker catalog number. When non-standard or optional line and/or load terminals are required, order by style number. Specify if factory installation is required.

### Line and Load Terminals

Maximum Breaker Amperes	Terminal Body Material	Wire Type	AWG Wire Range	Metric Wire Range mm <sup>2</sup>	Package of Three Terminals Catalog Number
<b>Standard Pressure Type Terminals</b>					
20 (EHD)	Steel	Cu/Al	14–10	2.5–4	<b>3T20FB</b> ②
100	Steel	Cu/Al	14–1/0	2.5–50	<b>3T100FB</b>
225	Aluminum	Cu/Al	4–4/0	25–95	<b>3TA225FD</b>
<b>Optional Pressure Terminals</b>					
50	Aluminum	Cu/Al	14–4	2.5–25	<b>3TA50FB</b> ②
100	Aluminum	Cu/Al	14–1/0	2.5–50	<b>3TA100FD</b>
200	Stainless steel	Cu	4–4/0	25–95	<b>3T150FB</b>
225	Copper	Cu	4–4/0	25–95	<b>3T225FD</b>
225	Aluminum	Cu/Al	6–300 kcmil	16–150	<b>3TA225FDK3</b> ③
225	Aluminum	Cu/Al	6–300 kcmil	16–150	<b>3TA225FDK</b> ③④

#### Notes

- ① Use on FDE, HFDE and FDCE electronic trip only.
- ② Not for use with ED, EDH, EDC breakers.
- ③ Includes terminal shield kit. Adds approximately 3 inches (76.2) to breaker height. Available for use on three-pole breaker only.
- ④ Replacement use only.

# 2.3

## Molded Case Circuit Breakers

### Series C

#### Line and Load Terminals

2

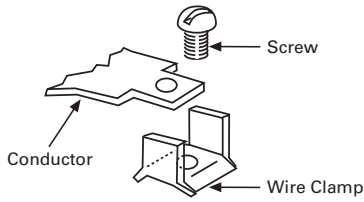

#### 3T20FB

Assemble wire clamp to bottom of conductor as shown.

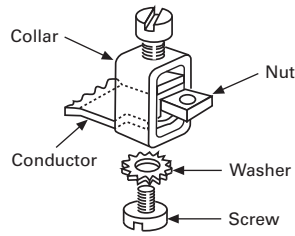

#### 3T100FB, 3T150FB

Insert collar enclosing conductor as shown. Locate nut on top of conductor and tighten securely with screw and washer.

**Caution:** Collar must surround conductor.

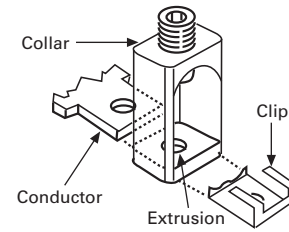

#### 3TA225FD

Insert collar enclosing conductor and center on extrusion on collar. Install clip with legs on top of conductor and snap end around bottom of collar.

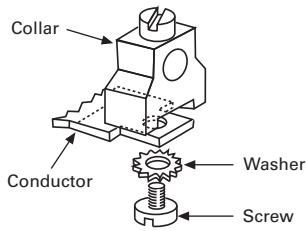

#### 3TA50FB

Assemble collar on top of conductor as shown. Tighten securely with screw and washer.

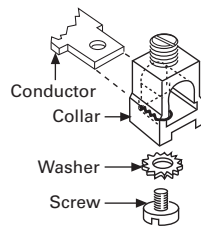

#### 3TA100FD

Collar slides onto conductor and is held in position by a screw and lockwasher.



#### 3TA225FDK3 (Up to 150 mm<sup>2</sup>)

Assemble collar on top of conductor as shown. Tighten securely with screw and washer. Terminal shield must be used with this collar.

**Note:** For 185 mm<sup>2</sup>, use 3TA225FDK1. Same illustration for 3TA225FDK

## Accessories

Different combinations of accessories can be supplied, depending on the types of accessories and the number of poles in the circuit breaker.

### Allowable Accessory Combinations

#### FD Frame Accessories

Description	Reference Page	Single-Pole		Two-Pole		Three-Pole ①			Four-Pole				
		Center	Left	Right	Left	Right	Left	Center	Right	Left	Center	Right	Neutral
<b>Internal Accessories (Only one internal accessory per pole)</b>													
Alarm lockout switch (make only)	V4-T2-275	■											
Alarm lockout (Make/Break)	V4-T2-275			■	□		□		■				
Alarm lockout (2Make/2Break)	V4-T2-275			■	□		□		■				
Auxiliary switch (1A, 1B)	V4-T2-277			■	■				■	■			■
Auxiliary switch (2A, 2B)	V4-T2-277			■	■				■	■			■
Auxiliary switch and alarm switch combination	V4-T2-279			■	□		□		■				
Shunt trip—standard	V4-T2-281			■	■				■	■			■
Shunt trip—low energy	V4-T2-285			■	■				■	■			
Undervoltage release mechanism	V4-T2-287			■	■				■	■			
<b>External Accessories</b>													
End cap kit	V4-T2-308		●	●	●	●	●	●	●	●	●	●	●
Keeper nut	V4-T2-308	●	●	●	●	●	●	●	●	●	●	●	●
Control wire terminal kit	V4-T2-309	●	●	●	●	●	●	●	●	●	●	●	●
Multewire connectors	V4-T2-310	●	●	●	●	●	●	●	●	●	●	●	●
Rear fed terminals	V4-T2-310	●	●	●	●	●	●	●	●	●	●	●	●
Base mounting hardware	V4-T2-310	●	●	●	●	●	●	●	●	●	●	●	●
Terminal shields	V4-T2-312	●	●	●	●	●	●	●	●	●	●	●	●
Terminal end covers	V4-T2-313					●	●	●					
Interphase barriers	V4-T2-313		●	●	●	●	●	●	●	●	●	●	●
Non-padlockable handle block	V4-T2-314	■	■			■				■			
Snap-on padlockable handle lock hasp	V4-T2-314	■	■			■				■			
Padlockable handle lock hasp	V4-T2-315			■		□		□		□		□	
Cylinder lock	V4-T2-315					■							
Key interlock kit	V4-T2-316			■		□		□		□		□	
Sliding bar interlock—requires two breakers	V4-T2-317					●	●	●					
Walking beam interlock—requires two breakers	V4-T2-317					●	●	●	●	●	●	●	●
Electrical (solenoid and motor) operators	V4-T2-318					●	●	●	●	●	●	●	●
Plug-in adapters	V4-T2-319		●	●	●	●	●	●	●	●	●	●	●
Rear connecting studs	V4-T2-321	●	●	●	●	●	●	●	●	●	●	●	●
Panelboard connecting straps	V4-T2-322	●	●	●	●	●	●	●	●	●	●	●	●
Handle mechanisms	V4-T2-432					●	●	●					
LFD current limiter	V4-T2-324					●	●	●					
IQ Energy Sentinel	V4-T2-324		●	●	●	●	●	●					
Cause of trip display	V4-T2-325					●			●				
Remote mount cause of trip display	V4-T2-325					●			●				
Cause of trip LED	V4-T2-325					●			●				
<b>Modifications (Refer to Eaton)</b>													
Special calibration	—	●	●	●	●	●	●	●	●	●	●	●	●
Moisture fungus treatment	V4-T2-116	●	●	●	●	●	●	●	●	●	●	●	●
Freeze-tested circuit breakers	—	●	●	●	●	●	●	●	●	●	●	●	●
Marine/naval application	—	●	●	●	●	●	●	●	●	●	●	●	●

#### Legend

- Applicable in indicated pole position
- May be mounted on left or right pole—not both
- Accessory available/modification available

#### Note

- ① Internal accessories are listed with Underwriters Laboratories (UL) for factory installation. They are not listed with UL for field installation.

## Technical Data and Specifications

2

### UL 489 Interrupting Capacity Ratings

Circuit Breaker Type	Number of Poles	Interrupting Capacity (kA Symmetrical Amperes)				Volts DC <sup>①</sup>	
		Volts AC (50/60 Hz)				125	250 <sup>②③</sup>
		240	277	480	600		
EDB	2, 3	22	—	—	—	10	—
EDS	2, 3	42	—	—	—	10	—
ED	2, 3	65	—	—	—	10	—
EDH	2, 3	100	—	—	—	10	—
EDC	2, 3	200	—	—	—	10	—
EHD	1	—	4	—	—	10	—
	2, 3	18	—	14	—	—	10
FDB	2, 3, 4	18	—	14	14	—	10
FD	1	—	35	—	—	10	—
	2, 3, 4	65	—	35	18	—	10
FDE <sup>④</sup>	3	65	—	35	18	—	—
HFD	1	—	65	—	—	10	—
	2, 3, 4	100	—	65	25	—	22
HFDE <sup>④</sup>	3	100	—	65	25	—	—
FDC <sup>⑤</sup>	2, 3, 4	200	—	100	35	—	22
FDCE <sup>④⑤⑥</sup>	3	200	—	100	25	—	—

### IEC 157-1 (P1) Interrupting Capacity Ratings (P1)

Circuit Breaker Type	Number of Poles	Interrupting Capacity (kA Symmetrical Amperes)				Volts DC <sup>①</sup>	
		Volts AC (50/60 Hz)				125	250 <sup>②③</sup>
		220, 240	380, 415	440	500		
EDB	2, 3	22	—	—	—	10	—
EDS	2, 3	42	—	—	—	10	—
ED	2, 3	65	—	—	—	10	—
EDH	2, 3	100	—	—	—	10	—
EDC	2, 3	200	—	—	—	10	—
EHD	1	—	14	—	—	10	—
	2, 3	18	—	14	—	—	10
FDB	2, 3, 4	18	14	14	14	—	10
FD	1	35	—	—	—	10	—
	2, 3, 4	65	35	35	18	—	10
HFD	1	65	—	—	—	10	—
	2, 3, 4	100	65	65	25	—	22
FDC	2, 3, 4	200	100	100	35	—	22

### 210+ and 310+ Electronic Trip Unit Accessories

Description	210+	310+	Catalog number
Electronic portable test kit	■	■	MTST230V
Trip unit tamper protection wire seal	■	■	5108A03H01
External neutral sensor (80 A) <sup>⑦</sup>		■	CTF080
External neutral sensor (160 A) <sup>⑦</sup>		■	CTF160
External neutral sensor (225 A) <sup>⑦</sup>		■	CTF225
Compact external neutral sensor (80 A) <sup>⑦</sup>		■	CTFD080
Compact external neutral sensor (160 A) <sup>⑦</sup>		■	CTFD160
Compact external neutral sensor (225 A) <sup>⑦</sup>		■	CTFD225
Breaker-mount cause-of-trip indication		■	TRIP-LED
Breaker-mount ammeter module		■	DIGIVIEW
Remote-mount ammeter module		■	DIGIVIEWR06

### UL 489 Current Limiting Data

Frame	Circuit	I <sub>p</sub> (kA)	I <sup>2</sup> T (10 <sup>6</sup> A <sup>2</sup> S)
FDC	240 V/200 kA	41.4	1.41
FDC	480 V/100 kA	38.9	2.50
FDC	600 V/35 kA	29.0	3.00

#### Notes

- ① DC ratings apply to substantially non-inductive circuits.
- ② Two-pole circuit breaker, or two poles of three-pole circuit breaker.
- ③ Time constant is 3 milliseconds minimum at 10 kA and 8 milliseconds minimum at 22 kA.
- ④ Electronics available on three-pole only, no DC rating for FDE, HFDE, FDCE.
- ⑤ Current limiting.
- ⑥ Check with Eaton for availability.
- ⑦ Neutral sensor required for four-wire systems if neutral protection is desired; sold separately.

## FDE 210+ and 310+ Specifications

Description	Digitrip RMS 210+	Digitrip RMS 310+
<b>Breaker type</b>		
Frame designation	FD	FD
Frames available	100 A, 150 A, 225 A	80 A, 160 A, 225 A
Continuous current range (A)	40–225 A	15–225 A
Ground fault pickup (A)	N/A	16–225 A
Interrupting capacities at 480 Vac (kAIC)	35, 65, 100	35, 65, 100
<b>Protection</b>		
Ordering options	LI, LSI	LS, LSI, LSG, LSIG
Arclash Reduction Maintenance System™ (or Maintenance Mode)	No	No
Interchangeable trip unit	No	No
High load alarm (suffix B20)	No	No
Ground fault alarm with trip (suffix B21)	No	No
Ground fault alarm, no trip (suffix B22)	No	No
Zone selective interlocking (suffix ZG)	No	LSI, LSIG
Cause of trip indication	No	Yes
Thru-cover accessories	No	No
Test kit available	Yes	Yes

## FDE 210+ Adjustability Specifications

210+ settings		FD Frame		
		100 A	150 A	225 A
$I_r$ = continuous current or long delay pickup (amperes) (all 210+)	$I_r$			
	A	40	70	100
	B	50	80	110
	C	60	90	125
	D	70	100	150
	E	80	110	175
	F	90	125	200
	G (= $I_n$ )	100	150	225
	$I_i$ (x $I_n$ ) = Instantaneous pickup (210+ LI version)	$I_i$	100	150
J–2x		200	300	450
K–2.5x		250	375	565
L–3x		300	450	675
M–3.5x		350	525	790
N–4x		400	600	900
O–5x		500	750	1125
P–6x		600	900	1350
Q–8x		800	1200	1800
R–10x		1000	1500	2250
S–12x ①		1200	1800	2400
Fixed instantaneous override (all 210+)		2400	2400	2400
"Isd (x Ir) / tsd = SD profile" ② (210+ LSI version)	$I_{sd} / t_{sd}$	100	150	225
	J	2x / 150	N/A	2x / 150
	K	2x / 300	N/A	2x / 300
	L	2x / $I^2t$	N/A	2x / $I^2t$
	M	4x / Inst	N/A	4x / Inst
	N	4x / 150	N/A	4x / 150
	O	4x / $I^2t$	N/A	4x / $I^2t$
	P	6x / Inst	N/A	6x / Inst
	Q	6x / 300	N/A	6x / 300
	R	10x / 150	N/A	10x / 150
	S	10x / 300	N/A	10x / 300

## FDE 310+ Adjustability Specifications

310+ Settings		FD Frame		
		80 A	160 A	225 A
$I_r$ = continuous current or long delay pickup (amperes) (All 310+)	$I_r$			
	A	15	60	100
	B	20	70	110
	C	30	80	125
	D	40	90	150
	E	50	100	160
	F	60	125	175
	G	70	150	200
	H (= $I_n$ )	80	160	225
$t_r$ = long delay time (seconds) (All 310+)	Position 1	2	2	2
	Position 2	4	4	4
	Position 3	7	7	7
	Position 4	10	10	10
	Position 5	12	12	12
	Position 6	15	15	15
	Position 7	20	20	20
	Position 8	24	24	24
	$I_{sd}$ (x $I_r$ ) = short delay pickup (All 310+)	Position 1	2x	2x
Position 2		3x	3x	3x
Position 3		4x	4x	4x
Position 4		5x	5x	5x
Position 5		6x	6x	6x
Position 6		7x	7x	7x
Position 7		8x	8x	8x
Position 8		10x	10x	10x
Position 9		12x	12x	12x
$t_{sd}$ = short delay time $I^2t$ (milliseconds) (LS, LSG)	Fixed	67 at10x	67 at10x	67 at10x
	Position 1	Inst	Inst	Inst
	Position 2	120	120	120
$t_{sd}$ = short delay time flat (milliseconds) (LSI, LSIG)	Position 3	300	300	300
	Position 1	16	32	45
	Position 2	24	48	67
$I_g$ = ground fault pickup (amperes) (LSG, LSIG)	Position 3	32	64	90
	Position 4	48	96	135
	Position 5	64	128	180
	Position 6	80	160	225
	Position 1	Inst	Inst	Inst
	Position 2	120	120	120
$t_g$ = ground fault delay time (milliseconds) (LSG, LSIG)	Position 3	300	300	300
	Independently Adjustable Instantaneous ( $I_i$ ) setting ①			
Maintenance Mode pickup ( $2.5 \times I_n$ ) (amperes) ②				

## Notes

- ① Not available for FD. Independently adjustable  $I_i$  setting available in LG, NG and RG ALSI and ALSIG trip units.
- ② Maintenance Mode not available for FD frames. It is available for KD, LD, MDL, LG, NG and RG.

# 2.3

## Molded Case Circuit Breakers

### Series C

#### Dimensions and Weights

Approximate Dimensions in Inches (mm)

2

#### FD Frame

Number of Poles	Width	Height	Depth
1	1.38 (35.1)	6.00 (152.4)	3.38 (86.0)
2	2.75 (70.0)	6.00 (152.4)	3.38 (86.0)
3	4.13 (105.0)	6.00 (152.4)	3.38 (86.0)
4	5.50 (139.7)	6.00 (152.4)	3.38 (86.0)

#### FD Frame, Three-Pole

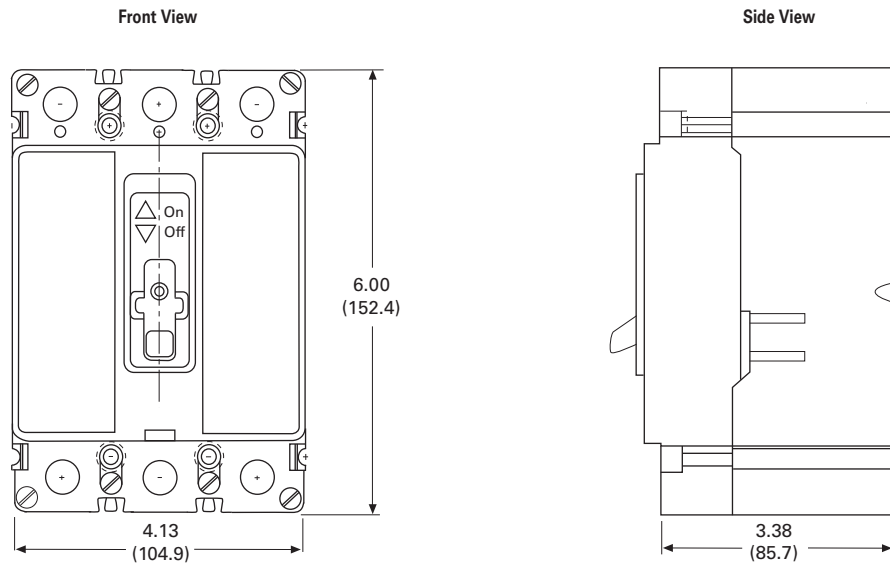

Approximate Shipping Weight Lbs (kg)

#### FD Frame

Breaker Type	Number of Poles			
	1	2	3	4
ED, EDB, EDS, EDH, EDC	—	3 (1.4)	4.5 (2.0)	—
EHD, FDB, FD, HFD, FDC	2 (0.9)	3 (1.4)	4.5 (2.0)	6 (2.7)
FDE, HFDE, FDCE	—	—	4.5 (2.0)	—

Typical J-Frame Breaker



## Contents

<i>Description</i>	<i>Page</i>
Product Overview . . . . .	V4-T2-116
Standards and Certifications . . . . .	V4-T2-117
Quick Reference . . . . .	V4-T2-118
G-Frame (15–100 Amperes) . . . . .	V4-T2-121
F-Frame (10–225 Amperes) . . . . .	V4-T2-135
J-Frame (70–250 Amperes)	
Catalog Number Selection . . . . .	V4-T2-154
Product Selection . . . . .	V4-T2-155
Accessories . . . . .	V4-T2-158
Technical Data and Specifications . . . . .	V4-T2-159
Dimensions and Weights . . . . .	V4-T2-160
K-Frame (70–400 Amperes) . . . . .	V4-T2-161
L-Frame (125–600 Amperes) . . . . .	V4-T2-185
M-Frame (300–800 Amperes) . . . . .	V4-T2-211
N-Frame (400–1200 Amperes) . . . . .	V4-T2-222
R-Frame (800–2500 Amperes) . . . . .	V4-T2-237
Motor Circuit Protectors (MCP) . . . . .	V4-T2-256
Motor Protection Circuit Breakers (MPCB) . . . . .	V4-T2-267
Type ELC Current Limiter Attachment (Size 0–4) . . . . .	V4-T2-269
Current Limiting Circuit Breaker Module . . . . .	V4-T2-270
Internal Accessories . . . . .	V4-T2-273
External Accessories . . . . .	V4-T2-304

## J-Frame (70–250 Amperes)

### Product Description

- All Eaton's J-Frame circuit breakers are HACR rated
- J-Frame circuit breakers are available as individual components (frame, trip unit, terminals), or factory assembled complete breakers
- J-Frame circuit breakers with non-interchangeable trip units are suitable for reverse feed use

# 2.3

## Molded Case Circuit Breakers

### Series C

#### Catalog Number Selection

This information is presented only as an aid to understanding catalog numbers. It is not to be used to build catalog numbers for circuit breakers or trip units.

2

#### Circuit Breaker/Frame

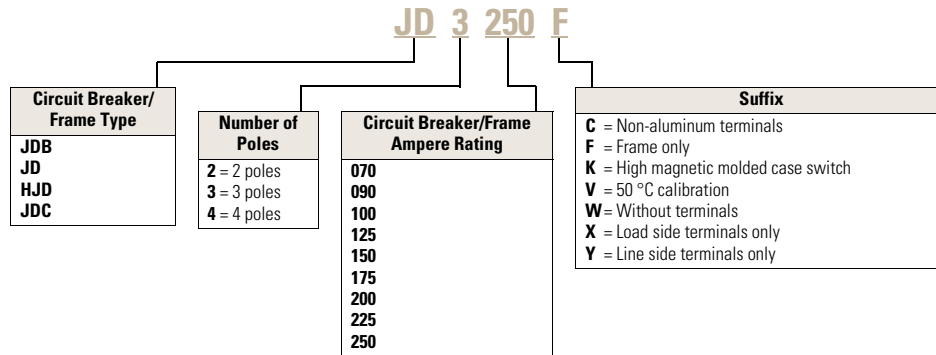

#### Trip Unit

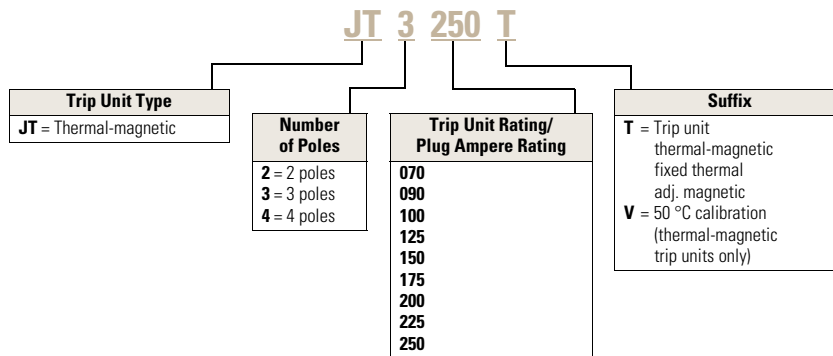

## Product Selection

## Types JD, HJD and JDC Thermal-Magnetic Circuit Breakers with Interchangeable Trip Units

Maximum Continuous Ampere Rating at 40 °C	Standard Interrupting Capacity 600 Vac Rated 35 kAIC at 480 Vac Factory Assembled Circuit Consisting of Frame, Trip Unit and Terminals ①	High Interrupting Capacity 600 Vac Rated 65 kAIC at 480 Vac Factory Assembled Circuit Consisting of Frame, Trip Unit and Terminals ①	Ultra High Interrupting Capacity Current Limiting 600 Vac Rated 100 kAIC at 480 Vac Factory Assembled Circuit Consisting of Frame, Trip Unit and Terminals ①	Thermal-Magnetic Trip Unit Only ①	Standard Terminals Only
	Catalog Number	Catalog Number	Catalog Number	Catalog Number	See Page V4-T2-157 for Optional Terminals  Catalog Number
<b>Two-Pole</b>					
70	JD2070	HJD2070	JDC2070	JT2070T	TA250KB ②
90	JD2090	HJD2090	JDC2090	JT2090T	
100	JD2100	HJD2100	JDC2100	JT2100T	
125	JD2125	HJD2125	JDC2125	JT2125T	
150	JD2150	HJD2150	JDC2150	JT2150T	
175	JD2175	HJD2175	JDC2175	JT2175T	
200	JD2200	HJD2200	JDC2200	JT2200T	
225	JD2225	HJD2225	JDC2225	JT2225T	
250	JD2250	HJD2250	JDC2250	JT2250T	
<b>Three-Pole</b>					
70	JD3070	HJD3070	JDC3070	JT3070T	TA250KB ②
90	JD3090	HJD3090	JDC3090	JT3090T	
100	JD3100	HJD3100	JDC3100	JT3100T	
125	JD3125	HJD3125	JDC3125	JT3125T	
150	JD3150	HJD3150	JDC3150	JT3150T	
175	JD3175	HJD3175	JDC3175	JT3175T	
200	JD3200	HJD3200	JDC3200	JT3200T	
225	JD3225	HJD3225	JDC3225	JT3225T	
250	JD3250	HJD3250	JDC3250	JT3250T	
<b>Four-Pole ③④</b>					
125	JD4125	HJD4125	JDC4125	JT3125T	TA250KB ②
150	JD4150	HJD4150	JDC4150	JT3150T	
175	JD4175	HJD4175	JDC4175	JT3175T	
200	JD4200	HJD4200	JDC4200	JT3200T	
225	JD4225	HJD4225	JDC4225	JT3225T	
250	JD4250	HJD4250	JDC4250	JT3250T	

## Notes

- ① Magnetic trip adjustable 5–10 times continuous ampere rating.
- ② Individually packed.
- ③ Fully rated neutral pole with no protection.
- ④ Neutral is in right pole.

#### Types JD, HJD and JDC Thermal-Magnetic Circuit Breakers – Frame Only

Standard Interrupting Capacity 600 Vac Rated 35 kAIC at 480 Vac Catalog Number	High Interrupting Capacity 600 Vac Rated 65 kAIC at 480 Vac Catalog Number	Ultra High Interrupting Capacity Current Limiting 600 Vac Rated 100 kAIC at 480 Vac Catalog Number
<b>Two-Pole</b>		
JD2250F	HJD2250F	JDC2250F
<b>Three-Pole</b>		
JD3250F	HJD3250F	JDC3250F
<b>Four-Pole</b>		
JD4250F	HJD4250F	JDC4250F

#### Type JDB Thermal-Magnetic Circuit Breakers with Non-Interchangeable Thermal-Magnetic Trip Units Suitable for Reverse Feed Application

Maximum Continuous Ampere Rating at 40 °C	600 Vac Rated, 250 Vdc Complete Circuit Breaker	
	Without Line and Load Terminals Catalog Number	With Standard Line and Load Terminals Only Catalog Number
<b>Two-Pole</b>		
70	JDB2070W	JDB2070
90	JDB2090W	JDB2090
100	JDB2100W	JDB2100
125	JDB2125W	JDB2125
150	JDB2150W	JDB2150
175	JDB2175W	JDB2175
200	JDB2200W	JDB2200
225	JDB2225W	JDB2225
250	JDB2250W	JDB2250
<b>Three-Pole</b>		
70	JDB3070W	JDB3070
90	JDB3090W	JDB3090
100	JDB3100W	JDB3100
125	JDB3125W	JDB3125
150	JDB3150W	JDB3150
175	JDB3175W	JDB3175
200	JDB3200W	JDB3200
225	JDB3225W	JDB3225
250	JDB3250W	JDB3250

#### Molded Case Switches

Eaton's molded case switches are used as compact switches in applications requiring high current switching capabilities. Molded case switches are constructed of circuit breaker

components and are of the high instantaneous automatic type. Molded case switches are listed in accordance with Underwriters Laboratories Standard UL 489.

#### Molded Case Switches

Maximum Continuous Ampere Rating at 40 °C	600 Vac Maximum, 250 Vdc Complete Circuit Breaker Only Without Line and Load Terminals		Standard Terminals Only
	Catalog Number	Suitable for Reverse Feed Use Catalog Number	See Page V4-T2-157 for Optional Terminals Catalog Number
<b>Two-Pole</b>			
250	JD2250KW	JDB2250KW	TA250KB ①
	HJD2250KW	HJDB2250KW	—
<b>Three-Pole</b>			
250	JD3250KW	JDB3250KW	TA250KB ①
	HJD3250KW	HJDB3250KW	—
<b>Four-Pole</b>			
250	JD4250KW	JDB4250KW	TA250KB ①
	HJD4250KW	HJDB4250KW	—

#### Notes

① Individually packed.

Molded case switches may open above 2500 amperes.

**Accessories Selection Guide and Ordering Information**

**Line and Load Terminals**

Eaton’s line and load terminals provide wire connecting capabilities for specific ranges of continuous current ratings and wire types. All terminals comply with Underwriters Laboratories Standards UL 486A and UL 486B and CSA Standard C22.2 No. 65, or Electrical Bulletin 1165.

Unless otherwise specified, J-Frame circuit breaker line and load terminals are shipped separately for field installation.

The bottom of the standard TA250KB terminal contains a recess that is positioned over the J-Frame circuit breaker terminal conductor.

**Ordering Information**

J-Frame circuit breakers use Cu/Al terminals as standard. When optional copper-only terminals are required, order by catalog number. Specify if factory installation is required.

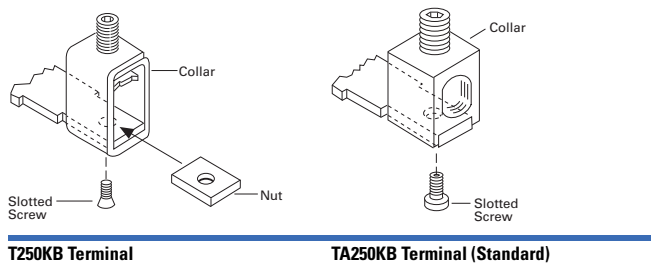

**Line and Load Terminals**

Maximum Breaker Amperes	Terminal Body Material	Wire Type	AWG Wire Range/ No. Conductors	Metric Wire Range mm <sup>2</sup>	Catalog Number
<b>Standard Cu/Al Pressure Terminals</b>					
250	Aluminum	Cu/Al	4–350 kcmil	25–185	<b>TA250KB</b>
<b>Optional Cu Pressure Terminals</b>					
250	Stainless Steel	Cu	4–350 kcmil	25–185	<b>T250KB</b>

#### Accessories

##### Allowable Accessory Combinations

Different combinations of accessories can be supplied, depending on the types of accessories and the number of poles in the circuit breaker.

##### JD Frame Accessories

Description	Reference Page	Two-, Three-Pole			Four-Pole			Neutral
		Left	Center	Right	Left	Center	Right	
<b>Internal Accessories (Only One Internal Accessory Per Pole)</b>								
Alarm lockout (Make/Break)	V4-T2-275	☐		☐	☐		☐	
Auxiliary switch (1A, 1B)	V4-T2-277	■		■	■		■	
Auxiliary switch (2A, 2B)	V4-T2-277	■		■	■		■	
Auxiliary switch and alarm switch combination	V4-T2-279	☐		☐	☐		☐	
Shunt trip—standard	V4-T2-282	■		■	■		■	
Shunt trip—low energy	V4-T2-285	■		■	■		■	
Undervoltage release mechanism	V4-T2-289	■		■	■		■	
<b>External Accessories</b>								
End cap kit	V4-T2-308	●	●	●	●	●	●	●
Plug nut	V4-T2-309	●	●	●	●	●	●	●
Control wire terminal kit	V4-T2-309	●	●	●	●	●	●	●
Multiwire connectors	V4-T2-310	●	●	●	●	●	●	●
Base mounting hardware	V4-T2-311	●	●	●	●	●	●	●
Terminal shields	V4-T2-312	●	●	●	●	●	●	●
Interphase barriers	V4-T2-313	●	●	●	●	●	●	●
Non-padlockable handle block	V4-T2-314		■			■		
Padlockable handle block	V4-T2-314		■			■		
Padlockable handle lock hasp	V4-T2-315	☐		☐	☐		☐	
Cylinder lock	V4-T2-315	☐		☐				
Key interlock kit	V4-T2-316	☐		☐	☐		☐	
Sliding bar interlock—requires two breakers	V4-T2-317	●	●	●				
Electrical (solenoid) operator	V4-T2-319	●	●	●	●	●	●	●
Plug-in adapters	V4-T2-319	●	●	●	●	●	●	●
Rear connecting studs	V4-T2-321	●	●	●	●	●	●	●
Panelboard connecting straps	V4-T2-322	●	●	●	●	●	●	●
Handle mechanisms	V4-T2-432	●	●	●	●	●	●	●
Handle extension	V4-T2-447	●	●	●	●	●	●	●
IQ Energy Sentinel	V4-T2-324	●	●	●				
<b>Modifications (Refer to Eaton)</b>								
Special calibration	—	●	●	●	●	●	●	●
Moisture fungus treatment	V4-T2-116	●	●	●	●	●	●	●
Freeze-tested circuit breakers	—	●	●	●	●	●	●	●
Marine/naval application	—	●	●	●	●	●	●	●

##### Legend

- Applicable in indicated pole position
- ☐ May be mounted on left or right pole—not both
- Accessory available/modification available

## Technical Data and Specifications

### UL 489 Interrupting Capacity Ratings

Circuit Breaker Type	Number of Poles	Interrupting Capacity (kA Symmetrical Amperes)				
		Volts AC (50/60 Hz)			Volts DC	
		240	480	600	125	250 <sup>①②</sup>
JDB	2, 3	65	35	18	—	10
JD	2, 3, 4	65	35	18	—	10
HJD	2, 3, 4	100	65	25	—	22
JDC <sup>③</sup>	2, 3, 4	200	100	35	—	22

### IEC 157-1 (P1) Interrupting Capacity Ratings

Circuit Breaker Type	Number of Poles	Interrupting Capacity (kA Symmetrical Amperes)					
		Volts AC (50/60 Hz)				Volts DC	
		240	380	415	600	125	250 <sup>①②</sup>
JD	2, 3, 4	65	35	35	—	—	10
HJD	2, 3, 4	100	65	65	—	—	22
JDC	2, 3, 4	200	100	100	—	—	22

### UL 489 Current Limiting Data

Frame	Circuit	I <sub>p</sub> (kA)	I <sup>2</sup> T (10 <sup>6</sup> A <sup>2</sup> S)
JDC	240 V/200 kA	42.6	1.36
JDC	480 V/100 kA	40.0	3.00
JDC	600 V/35 kA	31.9	3.10

#### Notes

- ① Two-pole circuit breaker or two outside poles of three-pole circuit breaker.
- ② Time constant is 3 milliseconds minimum at 10 kA and 8 milliseconds minimum at 22 kA.
- ③ Current limiting.

# 2.3

## Molded Case Circuit Breakers

### Series C

#### Dimensions and Weights

Approximate Dimensions in Inches (mm)

2

#### JD Frame

Number of Poles	Width	Height	Depth
2, 3	4.13 (105.0)	10.00 (254.0)	4.06 (104.1)
4	5.50 (139.7)	10.00 (254.0)	4.06 (104.1)

#### JD-Frame, Three-Pole

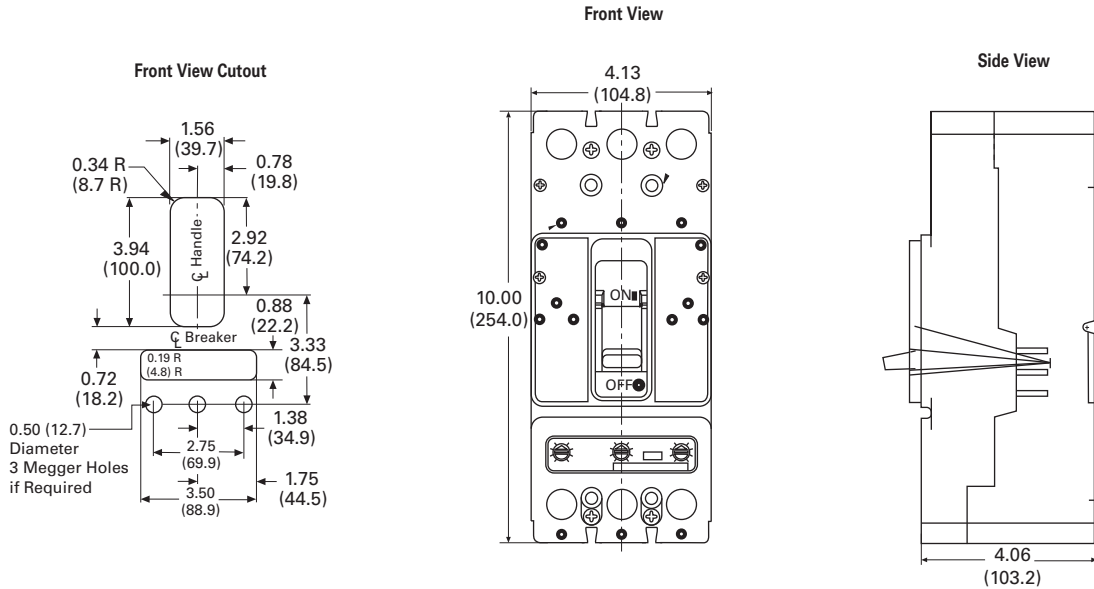

Approximate Shipping Weight in Lbs (kg)

#### JD Frame

Breaker Type	Complete Breaker			Frame Only			Trip Unit		
	Two-Pole	Three-Pole	Four-Pole	Two-Pole	Three-Pole	Four-Pole	Two-Pole	Three-Pole	Four-Pole
JDB	11.25 (5.1)	12.50 (5.7)	—	—	—	—	—	—	—
JD	11.25 (5.1)	12.50 (5.7)	13.25 (6.0)	9.00 (4.1)	10.00 (4.5)	10.50 (4.8)	2.00 (0.9)	2.00 (0.9)	2.25 (1.0)
HJD	11.25 (5.1)	12.50 (5.7)	13.25 (6.0)	9.00 (4.1)	10.00 (4.5)	10.50 (4.8)	2.00 (0.9)	2.00 (0.9)	2.25 (1.0)
JDC	12.25 (5.6)	13.50 (6.1)	14.25 (6.5)	10.00 (4.5)	11.00 (5.0)	11.50 (5.2)	2.00 (0.9)	2.00 (0.9)	2.25 (1.0)

Typical K-Frame Circuit Breaker



## Contents

<i>Description</i>	<i>Page</i>
Product Overview . . . . .	V4-T2-116
Standards and Certifications . . . . .	V4-T2-117
Quick Reference . . . . .	V4-T2-118
G-Frame (15–100 Amperes) . . . . .	V4-T2-121
F-Frame (10–225 Amperes) . . . . .	V4-T2-135
J-Frame (70–250 Amperes) . . . . .	V4-T2-153
K-Frame (70–400 Amperes)	
Catalog Number Selection . . . . .	V4-T2-162
Product Selection . . . . .	V4-T2-164
Accessories . . . . .	V4-T2-180
Technical Data and Specifications . . . . .	V4-T2-181
Dimensions and Weights . . . . .	V4-T2-184
L-Frame (125–600 Amperes) . . . . .	V4-T2-185
M-Frame (300–800 Amperes) . . . . .	V4-T2-211
N-Frame (400–1200 Amperes) . . . . .	V4-T2-222
R-Frame (800–2500 Amperes) . . . . .	V4-T2-237
Motor Circuit Protectors (MCP) . . . . .	V4-T2-256
Motor Protection Circuit Breakers (MPCB) . . . . .	V4-T2-267
Type ELC Current Limiter Attachment (Size 0–4) . . . . .	V4-T2-269
Current Limiting Circuit Breaker Module . . . . .	V4-T2-270
Internal Accessories . . . . .	V4-T2-273
External Accessories . . . . .	V4-T2-304

## K-Frame (70–400 Amperes)

### Product Description

- All Eaton K-Frame circuit breakers are HACR rated
- K-Frame circuit breakers are available as individual components (frame, trip unit, terminals), or factory assembled complete breakers
- K-Frame circuit breakers with non-interchangeable trip units are suitable for reverse feed use

# 2.3

## Molded Case Circuit Breakers

### Series C

2

#### Catalog Number Selection

This information is presented only as an aid to understanding catalog numbers. It is not to be used to build catalog numbers for circuit breakers or trip units.

#### K-Frame with Thermal-Magnetic Trip Unit Technology

##### Thermal-Magnetic Breakers and Frames ①

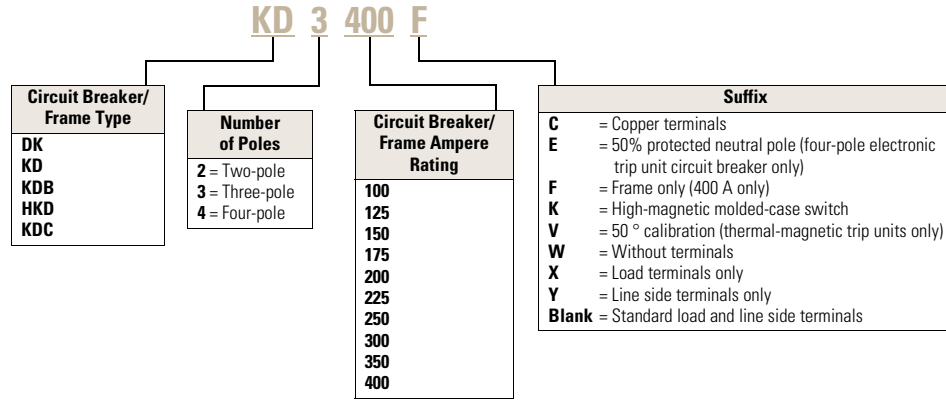

##### Thermal-Magnetic Trip Unit ①

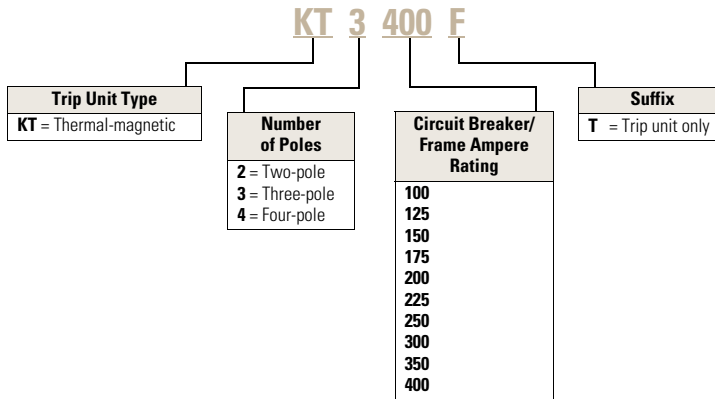

#### Notes

① Frames are the same for thermal-magnetic or 310+ electronic trip units, e.g., **KD3400F** or **HKD3400F**.

Ampere rating available with electronic trip unit only.

**K-Frame with 310+ Electronic Trip Unit Technology** ①

**310+ Circuit Breakers** ②

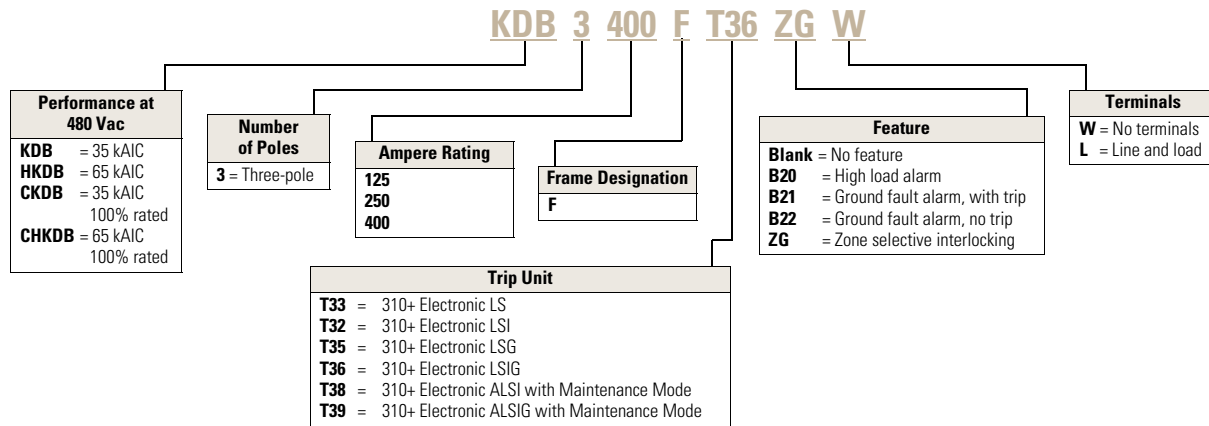

**310+ Electronic Trip Units** ③

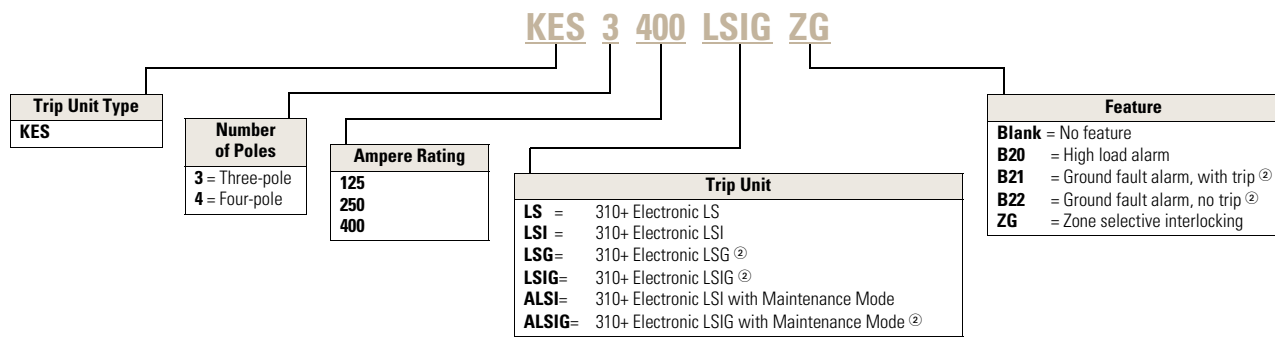

**K-Frame with OPTIM Trip Unit Technology**

**OPTIM Circuit Breakers**

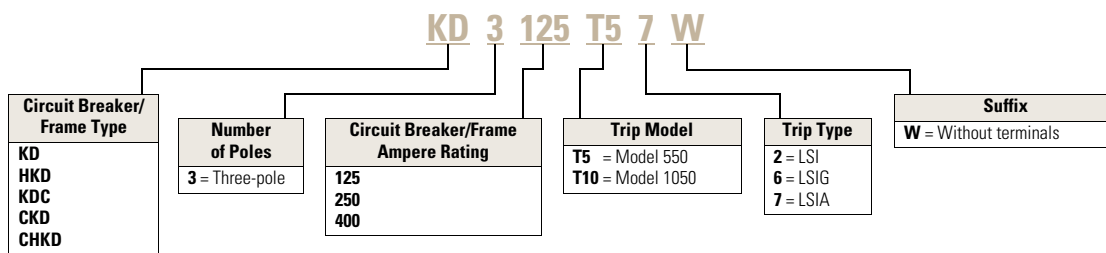

**Notes**

- ① Cannot combine 'B2X' suffixes with 'B2X' suffixes.
- ② Not available in four-pole configurations.
- ③ Frames are the same for thermal-magnetic or 310+ electronic trip units, e.g., **KD3400F**, **HKD3400F**, etc.

## Product Selection

## 2

## Types KD, HKD and KDC Thermal-Magnetic Circuit Breakers with Interchangeable Trip Units

Maximum Continuous Ampere Rating at 40 °C	Standard Interrupting Capacity 600 Vac Rated 35 kAIC at 480 Vac Factory Assembled Circuit Consisting of Frame, Trip Unit and Terminals ①	High Interrupting Capacity 600 Vac Rated 65 kAIC at 480 Vac Factory Assembled Circuit Consisting of Frame, Trip Unit and Terminals ①	Ultra High Interrupting Capacity Current Limiting 600 Vac Rated 100 kAIC at 480 Vac Factory Assembled Circuit Consisting of Frame, Trip Unit and Terminals ①	Thermal-Magnetic Trip Unit Only ①	Standard Terminals Only
	Catalog Number	Catalog Number	Catalog Number	For Use with Standard or High or Ultra High Interrupting Frames Catalog Number	See Page V4-T2-179 for Optional Terminals Catalog Number
<b>Two-Pole</b>					
100	KD2100	HKD2100	KDC2100	KT2100T	TA300K ②
125	KD2125	HKD2125	KDC2125	KT2125T	TA300K ②
150	KD2150	HKD2150	KDC2150	KT2150T	TA300K ②
175	KD2175	HKD2175	KDC2175	KT2175T	TA300K ②
200	KD2200	HKD2200	KDC2200	KT2200T	TA300K ②
225	KD2225	HKD2225	KDC2225	KT2225T	TA300K ②
250	KD2250	HKD2250	KDC2250	KT2250T	TA350K ②
300	KD2300	HKD2300	KDC2300	KT2300T	TA350K ②
350	KD2350	HKD2350	KDC2350	KT2350T	TA350K ②
400	KD2400	HKD2400	KDC2400	KT2400T	2TA400K ③
<b>Three-Pole</b>					
100	KD3100	HKD3100	KDC3100	KT3100T	TA300K ②
125	KD3125	HKD3125	KDC3125	KT3125T	TA300K ②
150	KD3150	HKD3150	KDC3150	KT3150T	TA300K ②
175	KD3175	HKD3175	KDC3175	KT3175T	TA300K ②
200	KD3200	HKD3200	KDC3200	KT3200T	TA300K ②
225	KD3225	HKD3225	KDC3225	KT3225T	TA300K ②
250	KD3250	HKD3250	KDC3250	KT3250T	TA350K ②
300	KD3300	HKD3300	KDC3300	KT3300T	TA350K ②
350	KD3350	HKD3350	KDC3350	KT3350T	TA350K ②
400	KD3400	HKD3400	KDC3400	KT3400T	3TA400K ③
<b>Four-Pole</b>					
100	KD4100	HKD4100	KDC4100	KT3100T	TA300K ②
125	KD4125	HKD4125	KDC4125	KT3125T	TA300K ②
175	KD4175	HKD4175	KDC4175	KT3175T	TA300K ②
200	KD4200	HKD4200	KDC4200	KT3200T	TA300K ②
225	KD4225	HKD4225	KDC4225	KT3225T	TA300K ②
250	KD4250	HKD4250	KDC4250	KT3250T	TA350K ②
300	KD4300	HKD4300	KDC4300	KT3300T	TA350K ②
350	KD4350	HKD4350	KDC4350	KT3350T	TA350K ②
400	KD4400	HKD4400	KDC4400	KT3400T	4TA400K ③

**Notes**

- ① Magnetic trip adjustable 5–10 times continuous ampere rating.
- ② Individually packed.
- ③ 2TA400K, 3TA400K and 4TA400K terminal kits contain one terminal for each pole and one terminal cover.

## Types KD, HKD and KDC Thermal-Magnetic Circuit Breakers—Frame Only

Standard Interrupting Capacity 600 Vac Rated 35 kAIC at 480 Vac	High Interrupting Capacity 600 Vac Rated 65 kAIC at 480 Vac	Ultra High Interrupting Capacity Current Limiting 600 Vac Rated 100 kAIC at 480 Vac
Catalog Number	Catalog Number	Catalog Number
<b>Two-Pole</b>		
KD2400F	HKD2400F	KDC2400F
<b>Three-Pole</b>		
KD3400F	HKD3400F	KDC3400F
<b>Four-Pole</b>		
KD4400F	HKD4400F	KDC4400F

## Types KD, HKD and KDC Electronic Circuit Breakers with Interchangeable 310+ Trip Units

Order as individual components: breaker frame, trip unit and terminals. See 310+ adjustability specifications on [Page V4-T2-182](#).

## Types KD, HKD and KDC Electronic Circuit Breakers with Interchangeable 310+ Trip Units—Three-Pole

Max. Cont. Ampere Rating at 40 °C	Circuit Breaker Frame Only			Digitrip RMS 310+ Trip Unit Only <sup>①</sup>				Neutral CT for LSG and LSI <sup>②③</sup>	Terminal Information
	Standard Interrupting Capacity 600 Vac Rated 35 kAIC at 480 Vac Catalog Number	High Interrupting Capacity 600 Vac Rated 65 kAIC at 480 Vac	Ultra High Interrupting Capacity Current Limiting 600 Vac Rated 100 kAIC at 480 Vac	Standard LS	Options LSI	LSG	LSIG		
125	KD3400F	HKD3400F	KDC3400F	KES3125LS	KES3125LSI	KES3125LSG	KES3125LSIG	LGFC125	See <a href="#">Page V4-T2-179</a>
250	KD3400F	HKD3400F	KDC3400F	KES3250LS	KES3250LSI	KES3250LSG	KES3250LSIG	LGFC250	
400	KD3400F	HKD3400F	KDC3400F	KES3400LS	KES3400LSI	KES3400LSG	KES3400LSIG	LGFC400	

Types KD, HKD and KDC Electronic Circuit Breakers with Interchangeable 310+ Trip Units—Four-Pole <sup>④⑤</sup>

Max. Cont. Ampere Rating at 40 °C	Circuit Breaker Frame Only			Digitrip RMS 310+ Trip Unit Only <sup>①</sup>				Neutral CT for LSG and LSI <sup>②③</sup>	Terminal Information
	Standard Interrupting Capacity 600 Vac Rated 35 kAIC at 480 Vac Catalog Number	High Interrupting Capacity 600 Vac Rated 65 kAIC at 480 Vac	Ultra High Interrupting Capacity Current Limiting 600 Vac Rated 100 kAIC at 480 Vac	Standard LS	Options LSI	LSG	LSIG		
125	KD4400F	HKD4400F	KDC4400F	KES4125LS	KES4125LSI	—	—	—	See <a href="#">Page V4-T2-179</a>
250	KD4400F	HKD4400F	KDC4400F	KES4250LS	KES4250LSI	—	—	—	
400	KD4400F	HKD4400F	KDC4400F	KES4400LS	KES4400LSI	—	—	—	

## Notes

- ① For AC use only.
- ② Required for four-wire systems if neutral protection is desired.
- ③ Included with LSG and LSI trip units.
- ④ Trip unit includes protected neutral pole. Use corresponding three-pole trip unit if protected neutral pole is not required.
- ⑤ Fully rated neutral pole protection is standard. For 50% rated protection on neutral pole, add Suffix E to four-pole trip unit catalog number.

# 2.3

## Molded Case Circuit Breakers

### Series C

#### Type KDB with Digitrip 310+ Non-Interchangeable Trip Unit Suitable for Reverse Feed

See 310+ adjustability specifications on [Page V4-T2-182](#).

2

Factory Assembled Circuit Breaker Consisting of Frame and Trip Unit Less Terminals <sup>①</sup>							
Maximum Continuous Ampere Rating at 40 °C	Number of Poles	Standard LS	Optional LSI	LSG	LSIG	Neutral CT for LSG and LSIG <sup>②③</sup>	Terminal Information
		Adjustable Short Time Pickup with I <sup>2</sup> t Short Delay Ramp Catalog Number	Independently Adjustable Short Time Pickup and Delay	Adjustable Short Time Pickup with I <sup>2</sup> t Short Delay and Ground Fault Protection	Independently Adjustable Short Time Pickup and Ground Fault Protection		
125	3	KDB3125FT33W	KDB3125FT32W	KDB3125FT35W	KDB3125FT36W	LGFACT125	See Page V4-T2-180
250	3	KDB3250FT33W	KDB3250FT32W	KDB3250FT35W	KDB3250FT36W	LGFACT250	
400	3	KDB3400FT33W	KDB3400FT32W	KDB3400FT35W	KDB3400FT36W	LGFACT400	

#### Type HKDB with Digitrip 310+ Non-Interchangeable Trip Unit Suitable for Reverse Feed

See 310+ adjustability specifications on [Page V4-T2-182](#).

Factory Assembled Circuit Breaker Consisting of Frame and Trip Unit Less Terminals <sup>①</sup>							
Maximum Continuous Ampere Rating at 40 °C	Number of Poles	Standard LS	Optional LSI	LSG	LSIG	Neutral CT for LSG and LSIG <sup>②③</sup>	Terminal Information
		Adjustable Short Time Pickup with I <sup>2</sup> t Short Delay Ramp Catalog Number	Independently Adjustable Short Time Pickup and Delay	Adjustable Short Time Pickup with I <sup>2</sup> t Short Delay and Ground Fault Protection	Independently Adjustable Short Time Pickup and Ground Fault Protection		
125	3	HKDB3125FT33W	HKDB3125FT32W	HKDB3125FT35W	HKDB3125FT36W	LGFACT125	See Page V4-T2-180
250	3	HKDB3250FT33W	HKDB3250FT32W	HKDB3250FT35W	HKDB3250FT36W	LGFACT250	
400	3	HKDB3400FT33W	HKDB3400FT32W	HKDB3400FT35W	HKDB3400FT36W	LGFACT400	

#### 100% Rated Types CKD and CHKD Electronic Circuit Breakers

The NEC allows the breaker to be rated at 100% of its frame size in an assembly, provided that 90 °C wire is applied at the 75 °C ampacity. All 100% rated circuit breakers have electronic trip units.

#### 100% Rated Types CKD and CHKD Electronic Circuit Breakers—Three-Pole

See 310+ adjustability specifications on [Page V4-T2-182](#).

Maximum Continuous Ampere Rating at 40 °C	Circuit Breaker Frame Only		Digitrip RMS 310+ Trip Unit Only		Adjustable Short Time Pickup with I <sup>2</sup> t Short Delay and Ground Fault Protection	Independently Adjustable Short Time Pickup and Delay and Ground Fault Protection	Neutral CT for LSG and LSIG <sup>②③</sup>	Terminal Information
	Standard Interrupting Capacity	High Interrupting Capacity	Standard	Options				
	35 kAIC at 480 Vac Catalog Number	65 kAIC at 480 Vac	Adjustable Short Time Pickup with I <sup>2</sup> t Short Delay Ramp	Independently Adjustable Short Time Pickup and Delay				
125	CKD3400F	CHKD3400F	KES3125LS	KES3125LSI	KES3125LSG	KES3125LSIG	LGFACT125	See Page V4-T2-179
250	CKD3400F	CHKD3400F	KES3250LS	KES3250LSI	KES3250LSG	KES3250LSIG	LGFACT250	
400	CKD3400F	CHKD3400F	KES3400LS	KES3400LSI	KES3400LSG	KES3400LSIG	LGFACT400	

#### Notes

- ① For AC use only.
- ② Required for four-wire systems if neutral protection is desired.
- ③ Included with LSG and LSIG trip units.

**Types DK and KDB Thermal-Magnetic Circuit Breakers with Non-Interchangeable Trip Units**

Suitable for reverse feed application.

**Types DK and KDB Thermal-Magnetic Circuit Breakers with Non-Interchangeable Trip Units**

Maximum Continuous Ampere Rating at 40 °C	240 Vac Rated, 250 Vdc Complete Circuit Breaker			600 Vac Rated, 250 Vdc Complete Circuit Breaker	
	Without Line and Load Terminals Catalog Number	With Line Terminals Only Catalog Number	With Standard Line and Load Terminals Only Catalog Number	Without Line and Load Terminals Catalog Number	With Standard Line and Load Terminals Catalog Number
<b>Two-Pole</b>					
100	—	—	—	KDB2100W	KDB2100
125	—	—	—	KDB2125W	KDB2125
150	—	—	—	KDB2150W	KDB2150
175	—	—	—	KDB2175W	KDB2175
200	—	—	—	KDB2200W	KDB2200
225	—	—	—	KDB2225W	KDB2225
250	DK2250W	DK2250Y	DK2250	KDB2250W	KDB2250
300	DK2300W	DK2300Y	DK2300	KDB2300W	KDB2300
350	DK2350W	DK2350Y	DK2350	KDB2350W	KDB2350
400	DK2400W	DK2400Y	DK2400	KDB2400W	KDB2400
<b>Three-Pole</b>					
100	—	—	—	KDB3100W	KDB3100
125	—	—	—	KDB3125W	KDB3125
150	—	—	—	KDB3150W	KDB3150
175	—	—	—	KDB3175W	KDB3175
200	—	—	—	KDB3200W	KDB3200
225	—	—	—	KDB3225W	KDB3225
250	DK3250W	DK3250Y	DK3250	KDB3250W	KDB3250
300	DK3300W	DK3300Y	DK3300	KDB3300W	KDB3300
350	DK3350W	DK3350Y	DK3350	KDB3350W	KDB3350
400	DK3400W	DK3400Y	DK3400	KDB3400W	KDB3400

# 2.3

## Molded Case Circuit Breakers

### Series C

2

#### Molded Case Switches

Eaton's molded case switches are used as compact switches in applications requiring high current switching capabilities. Molded case switches are constructed of circuit breaker

components and are of the high instantaneous automatic type. Molded case switches are listed in accordance with Underwriters Laboratories Standard UL 489.

#### Molded Case Switches

Maximum Continuous Ampere Rating at 40 °C	240 Vac Maximum, 250 Vdc	600 Vac Maximum, 250 Vdc	600 Vac Maximum, 250 Vdc
	Complete Circuit Breaker with Standard Line and Load Terminals Catalog Number	Complete Circuit Breaker with Standard Line and Load Terminals Catalog Number	Complete Circuit Breaker with Standard Line and Load Terminals. Suitable for Reverse Feed Use Catalog Number
<b>Two-Pole</b>			
400	DK2400K	KD2400K	KDB2400K
	—	HKD2400K	HKDB2400K
<b>Three-Pole</b>			
400	DK3400K	KD3400K	KDB3400K
	—	HKD3400K	HKDB3400K
<b>Four-Pole</b>			
400	—	KD4400K	KDB4400K
	—	HKD4400K	HKDB4400K

**Note**

Molded case switches may open above 4000 amperes.

**Digitrip OPTIM 550 Electronic Circuit Breakers with Interchangeable Rating Plug**

Order as individual components: breaker frame (which includes trip unit), rating plug, terminals.

**Digitrip OPTIM 550 Electronic Circuit Breakers with Interchangeable Rating Plug**

Maximum Continuous Ampere Rating at 40 °C	Circuit Breaker Frame Only			Digitrip OPTIM Rating Plug Only	
	LSI Catalog Number	LSIG Catalog Number	LSIA Catalog Number	Ampere Rating	Fixed Rating Plug Catalog Number
<b>Three-Pole Standard Interrupting Capacity 600 Vac Rated 35 kAIC at 480 Vac</b>					
125	KD3125T52W	KD3125T56W	KD3125T57W	70	ORPK125A70
				90	ORPK125A90
				100	ORPK125A100
				110	ORPK125A110
				125	ORPK125A125
250	KD3250T52W	KD3250T56W	KD3250T57W	125	ORPK025A125
				150	ORPK025A150
				175	ORPK025A175
				200	ORPK025A200
				225	ORPK025A225
				250	ORPK025A250
400	KD3400T52W	KD3400T56W	KD3400T57W	200	ORPK40A200
				225	ORPK40A225
				250	ORPK40A250
				300	ORPK40A300
				350	ORPK40A350
				400	ORPK40A400

**Notes**

① Long delay I<sup>4</sup>t response selection limits short delay time to flat response.

② Zone interlocking, PowerNet, or both features can be added at the factory by adding suffixes **ZG**, **PN** or **ZGP** respectively to above catalog number.

## Digitrip OPTIM 550 Electronic Circuit Breakers with Interchangeable Rating Plug, continued

Maximum Continuous Ampere Rating at 40 °C	Circuit Breaker Frame Only			Digitrip OPTIM Rating Plug Only	
	LSI Catalog Number	LSIG Catalog Number	LSIA Catalog Number	Ampere Rating	Fixed Rating Plug Catalog Number
	L – Adjustable Long Delay Pickup (I <sub>t</sub> ) with Adjustable Long Delay Time (I <sup>2</sup> t or I <sup>4</sup> t Response) <sup>①</sup> S – Adjustable Short Delay Pickup with Adjustable Short Delay Time (I <sup>2</sup> t or Flat Response) I – Adjustable Instantaneous Pickup G – Adjustable Ground Fault Pickup with Adjustable Ground Fault Time (I <sup>2</sup> t or Flat Response) A – Adjustable Ground Fault Alarm with Adjustable Ground Fault Time (I <sup>2</sup> t or Flat Response) OPTIM 550 <sup>②</sup>				
<b>Three-Pole High Interrupting Capacity 600 Vac Rated 65 kAIC at 480 Vac</b>					
125	HKD3125T52W	HKD3125T56W	HKD3125T57W	70	ORPK125A70
				90	ORPK125A90
				100	ORPK125A100
				110	ORPK125A110
				125	ORPK125A125
250	HKD3250T52W	HKD3250T56W	HKD3250T57W	125	ORPK025A125
				150	ORPK025A150
				175	ORPK025A175
				200	ORPK025A200
				225	ORPK025A225
				250	ORPK025A250
400	HKD3400T52W	HKD3400T56W	HKD3400T57W	200	ORPK40A200
				225	ORPK40A225
				250	ORPK40A250
				300	ORPK40A300
				350	ORPK40A350
				400	ORPK40A400

**Notes**

<sup>①</sup> Long delay I<sup>4</sup>t response selection limits short delay time to flat response.

<sup>②</sup> Zone interlocking, PowerNet, or both features can be added at the factory by adding suffixes **ZG**, **PN** or **ZGP** respectively to above catalog number.

## Digitrip OPTIM 550 Electronic Circuit Breakers with Interchangeable Rating Plug, continued

Maximum Continuous Ampere Rating at 40 °C	Circuit Breaker Frame Only			Digitrip OPTIM Rating Plug Only	
	LSI Catalog Number	LSIG Catalog Number	LSIA Catalog Number	Ampere Rating	Fixed Rating Plug Catalog Number
	L – Adjustable Long Delay Pickup (I <sub>1</sub> ) with Adjustable Long Delay Time (I <sup>2</sup> t or I <sup>4</sup> t Response) ① S – Adjustable Short Delay Pickup with Adjustable Short Delay Time (I <sup>2</sup> t or Flat Response) I – Adjustable Instantaneous Pickup G – Adjustable Ground Fault Pickup with Adjustable Ground Fault Time (I <sup>2</sup> t or Flat Response) A – Adjustable Ground Fault Alarm with Adjustable Ground Fault Time (I <sup>2</sup> t or Flat Response) OPTIM 550 ②				
<b>Three-Pole Ultra High Interrupting Capacity Current Limiting 600 Vac Rated 100 kAIC at 480 Vac</b>					
125	KDC3125T52W	KDC3125T56W	KDC3125T57W	70	ORPK125A70
				90	ORPK125A90
				100	ORPK125A100
				110	ORPK125A110
				125	ORPK125A125
250	KDC3250T52W	KDC3250T56W	KDC3250T57W	125	ORPK025A125
				150	ORPK025A150
				175	ORPK025A175
				200	ORPK025A200
				225	ORPK025A225
400	KDC3400T52W	KDC3400T56W	KDC3400T57W	250	ORPK025A250
				200	ORPK40A200
				225	ORPK40A225
				250	ORPK40A250
				300	ORPK40A300
				350	ORPK40A350
				400	ORPK40A400

**Notes**

① Long delay I<sup>4</sup>t response selection limits short delay time to flat response.

② Zone interlocking, PowerNet, or both features can be added at the factory by adding suffixes **ZG**, **PN** or **ZGP** respectively to above catalog number.

# 2.3

## Molded Case Circuit Breakers

### Series C

#### Digitrip OPTIM 1050 Electronic Circuit Breakers with Interchangeable Rating Plug

Order as individual components: breaker frame (which includes trip unit), rating plug, terminals.

2

#### Digitrip OPTIM 1050 Electronic Circuit Breakers with Interchangeable Rating Plug

Maximum Continuous Ampere Rating at 40 °C	Circuit Breaker Frame Only		Digitrip OPTIM Rating Plug Only	
	LSIG Catalog Number	LSIA Catalog Number	Ampere Rating	Fixed Rating Plug Catalog Number
<b>Three-Pole Standard Interrupting Capacity 600 Vac Rated 35 kAIC at 480 Vac</b>				
125	KD3125T106W	KD3125T107W	70	ORPK125A70
			90	ORPK125A90
			100	ORPK125A100
			110	ORPK125A110
			125	ORPK125A125
250	KD3250T106W	KD3250T107W	125	ORPK025A125
			150	ORPK025A150
			175	ORPK025A175
			200	ORPK025A200
			225	ORPK025A225
			250	ORPK025A250
400	KD3400T106W	KD3400T107W	200	ORPK40A200
			225	ORPK40A22
			250	ORPK40A250
			300	ORPK40A300
			350	ORPK40A350
			400	ORPK40A400

**Notes**

- ① Long delay I<sup>4</sup>t response selection limits short delay time to flat response.
- ② Factory sealed.

## Digitrip OPTIM 1050 Electronic Circuit Breakers with Interchangeable Rating Plug, continued

Maximum Continuous Ampere Rating at 40 °C	Circuit Breaker Frame Only		Digitrip OPTIM Rating Plug Only	
	LSIG Catalog Number	LSIA Catalog Number	Ampere Rating	Fixed Rating Plug Catalog Number
<b>Three-Pole High Interrupting Capacity 600 Vac Rated 65 kAIC at 480 Vac</b>				
125	HKD3125T106W	HKD3125T107W	70	ORPK125A70
			90	ORPK125A90
			100	ORPK125A100
			110	ORPK125A110
			125	ORPK125A125
250	HKD3250T106W	HKD3250T107W	125	ORPK025A125
			150	ORPK025A150
			175	ORPK025A175
			200	ORPK025A200
			225	ORPK025A225
400	HKD3400T106W	HKD3400T107W	250	ORPK025A250
			200	ORPK40A200
			225	ORPK40A225
			250	ORPK40A250
			300	ORPK40A300
			350	ORPK40A350
			400	ORPK40A400

**Notes**

- ① Long delay I<sup>4</sup>t response selection limits short delay time to flat response.  
 ② Factory sealed.

#### Digitrip OPTIM 1050 Electronic Circuit Breakers with Interchangeable Rating Plug, continued

Maximum Continuous Ampere Rating at 40 °C	Circuit Breaker Frame Only		Digitrip OPTIM Rating Plug Only	
	LSIG Catalog Number	LSIA Catalog Number	Ampere Rating	Fixed Rating Plug Catalog Number
	L – Adjustable Long Delay Pickup (I <sub>r</sub> ) with Adjustable Long Delay Time (I <sup>2</sup> t or I <sup>4</sup> t Response) ① S – Adjustable Short Delay Pickup with Adjustable Short Delay Time (I <sup>2</sup> t or Flat Response) I – Adjustable Instantaneous Pickup G – Adjustable Ground Fault Pickup with Adjustable Ground Fault Time (I <sup>2</sup> t or Flat Response) A – Adjustable Ground Fault Alarm with Adjustable Ground Fault Time (I <sup>2</sup> t or Flat Response)			
	OPTIM 1050 ②			
<b>Three-Pole Ultra High Interrupting Capacity Current Limiting 600 Vac Rated 100 kAIC at 480 Vac</b>				
125	KDC3125T106W	KDC3125T107W	70	ORPK125A70
			90	ORPK125A90
			100	ORPK125A100
			110	ORPK125A110
			125	ORPK125A125
250	KDC3250T106W	KDC3250T107W	125	ORPK025A125
			150	ORPK025A150
			175	ORPK025A175
			200	ORPK025A200
			225	ORPK025A225
400	KDC3400T106W	KDC3400T107W	250	ORPK025A250
			200	ORPK40A200
			225	ORPK40A225
			250	ORPK40A250
			300	ORPK40A300
			350	ORPK40A350
			400	ORPK40A400

**Notes**

- ① Long delay I<sup>4</sup>t response selection limits short delay time to flat response.
- ② Factory sealed.



#### 100% Rated Digitrip OPTIM 550 Electronic Circuit Breakers with Interchangeable Rating Plug, continued

Maximum Continuous Ampere Rating at 40 °C	Circuit Breaker Frame Only			Digitrip OPTIM Rating Plug Only	
	LSI Catalog Number	LSIG Catalog Number	LSIA Catalog Number	Ampere Rating	Fixed Rating Plug Catalog Number
	L – Adjustable Long Delay Pickup ( $I_L$ ) with Adjustable Long Delay Time ( $I^2t$ or $I^4t$ Response) <sup>①</sup> S – Adjustable Short Delay Pickup with Adjustable Short Delay Time ( $I^2t$ or Flat Response) I – Adjustable Instantaneous Pickup G – Adjustable Ground Fault Pickup with Adjustable Ground Fault Time ( $I^2t$ or Flat Response) A – Adjustable Ground Fault Alarm with Adjustable Ground Fault Time ( $I^2t$ or Flat Response) OPTIM 550 <sup>②</sup>				
<b>Three-Pole High Interrupting Capacity 600 Vac Rated 65 kAIC at 480 Vac</b>					
125	CHKD3125T52W	CHKD3125T56W	CHKD3125T57W	70	ORPK125A70
				90	ORPK125A90
				100	ORPK125A100
				110	ORPK125A110
				125	ORPK125A125
250	CHKD3250T52W	CHKD3250T56W	CHKD3250T57W	125	ORPK025A125
				150	ORPK025A150
				175	ORPK025A175
				200	ORPK025A200
				225	ORPK025A225
400	CHKD3400T52W	CHKD3400T56W	CHKD3400T57W	250	ORPK025A250
				200	ORPK40A200
				225	ORPK40A225
				250	ORPK40A250
				300	ORPK40A300
				350	ORPK40A350
				400	ORPK40A400

**Notes**

- ① Long delay  $I^4t$  response selection limits short delay time to flat response.
- ② Zone interlocking, PowerNet, or both features can be added at the factory by adding suffixes **ZG**, **PN** or **ZGP** respectively to above catalog number.

**100% Rated Digitrip OPTIM 1050 Electronic Circuit Breakers with Interchangeable Rating Plug**

Order as individual components: breaker frame (which includes trip unit), rating plug, terminals.

**100% Rated Digitrip OPTIM 1050 Electronic Circuit Breakers with Interchangeable Rating Plug**

Maximum Continuous Ampere Rating at 40 °C	Circuit Breaker Frame Only		Digitrip OPTIM Rating Plug Only	
	LSIG Catalog Number	LSIA Catalog Number	Ampere Rating	Fixed Rating Plug Catalog Number
<b>OPTIM 1050</b> ②				
<b>Three-Pole Standard Interrupting Capacity 600 Vac Rated 35 kAIC at 480 Vac</b>				
125	CKD3125T106W	CKD3125T107W	70	ORPK125A70
			90	ORPK125A90
			100	ORPK125A100
			110	ORPK125A110
			125	ORPK125A125
250	CKD3250T106W	CKD3250T107W	125	ORPK025A125
			150	ORPK025A150
			175	ORPK025A175
			200	ORPK025A200
			225	ORPK025A225
400	CKD3400T106W	CKD3400T107W	250	ORPK025A250
			200	ORPK40A200
			225	ORPK40A225
			250	ORPK40A250
			300	ORPK40A300
			350	ORPK40A350
			400	ORPK40A400

**Notes**① Long delay I<sup>4</sup>t response selection limits short delay time to flat response.

② Factory sealed.

#### 100% Rated Digitrip OPTIM 1050 Electronic Circuit Breakers with Interchangeable Rating Plug, continued

Maximum Continuous Ampere Rating at 40 °C	Circuit Breaker Frame Only		Digitrip OPTIM Rating Plug Only	
	LSIG Catalog Number	LSIA Catalog Number	Ampere Rating	Fixed Rating Plug Catalog Number
	<b>L – Adjustable Long Delay Pickup (<math>I_L</math>) with Adjustable Long Delay Time (<math>I^2t</math> or <math>I^4t</math> Response) ①</b> <b>S – Adjustable Short Delay Pickup with Adjustable Short Delay Time (<math>I^2t</math> or Flat Response)</b> <b>I – Adjustable Instantaneous Pickup</b> <b>G – Adjustable Ground Fault Pickup with Adjustable Ground Fault Time (<math>I^2t</math> or Flat Response)</b> <b>A – Adjustable Ground Fault Alarm with Adjustable Ground Fault Time (<math>I^2t</math> or Flat Response)</b> <b>OPTIM 1050 ②</b>			
<b>Three-Pole High Interrupting Capacity 600 Vac Rated 65 kAIC at 480 Vac</b>				
125	CHKD3125T106W	CHKD3125T107W	70	ORPK125A70
			90	ORPK125A90
			100	ORPK125A100
			110	ORPK125A110
			125	ORPK125A125
250	CHKD3250T106W	CHKD3250T107W	125	ORPK025A125
			150	ORPK025A150
			175	ORPK025A175
			200	ORPK025A200
			225	ORPK025A225
400	CHKD3400T106W	CHKD3400T107W	250	ORPK025A250
			200	ORPK40A200
			225	ORPK40A225
			250	ORPK40A250
			300	ORPK40A300
			350	ORPK40A350
			400	ORPK40A400

**Notes**

- ① Long delay  $I^4t$  response selection limits short delay time to flat response.
- ② Factory sealed.

**Accessories Selection Guide and Ordering Guide**

**Line and Load Terminals**

Eaton’s line and load terminals provide wire connecting capabilities for specific ranges of continuous current ratings and wire types. All terminals comply with Underwriters Laboratories Standards

UL 486A and UL 486B and CSA Standard C22.2 No. 65, or Electrical Bulletin 1165. Unless otherwise specified, K-Frame circuit breaker line and load terminals are shipped separately for field installation.

**Ordering Information**

K-Frame circuit breakers use Cu/Al terminals as standard. When optional copper or Cu/Al terminals are required, order by catalog number. Specify if factory installation is required.

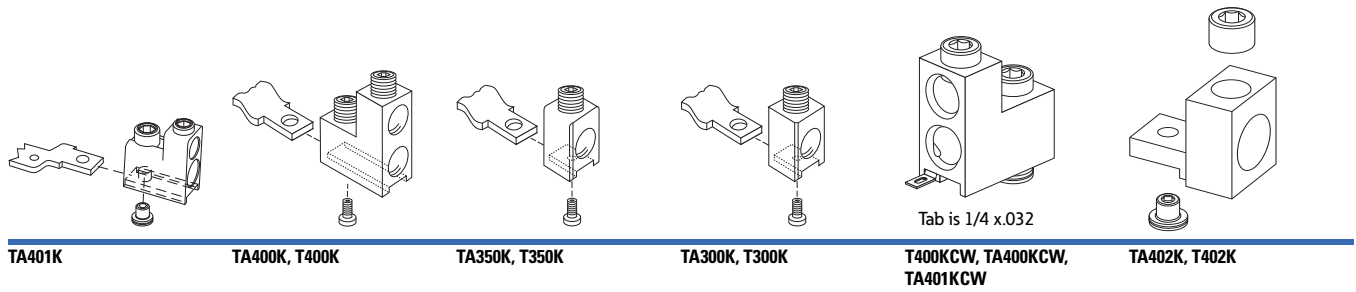

**Line and Load Terminals**

Maximum Breaker Amperes	Terminal Body Material	Wire Type	AWG Wire Range/No. Conductors	Metric Wire Range mm <sup>2</sup>	Terminal	Terminals with Control Wire Termination
					Catalog Number	Catalog Number
<b>Standard Cu/Al Pressure Terminals</b>						
225	Aluminum	Cu/Al	3–350 (1)	35–185	<b>TA300K</b> ①	—
400	Aluminum	Cu/Al	250–500 (1)	120–240	<b>TA350K</b> ①	—
400	Aluminum	Cu/Al	3/0–250 (2)	95–120	<b>2TA400K</b> ②③	<b>2TA400KCW</b> ②③
400	Aluminum	Cu/Al	3/0–250 (2)	95–120	<b>3TA400K</b> ②④	<b>3TA400KCW</b> ②④
400	Aluminum	Cu/Al	3/0–250 (2)	95–120	<b>4TA400K</b> ⑤⑥	<b>4TA400KCW</b> ⑤⑥
<b>Optional Copper and Cu/Al Pressure Type Terminals</b>						
225	Copper	Cu	3–350 (1)	35–185	<b>T300K</b> ①	—
400	Copper	Cu	250–500 (1)	120–240	<b>T350K</b> ①	—
400	Copper	Cu	3/0–250 (2)	95–120	<b>2T400K</b> ③	<b>2T400KCW</b> ②③
					<b>3T400K</b> ④	<b>3T400KCW</b> ②④
					<b>4T400K</b> ⑤	<b>4T400KCW</b> ⑤⑥
400	Aluminum	Cu/Al	2/0–250 (2) or 2/0–500 (1)	70–120	<b>2TA401K</b> ②③	<b>2TA401KCW</b> ②③
				70–240	<b>3TA401K</b> ②④	<b>3TA401KCW</b> ②④
				70–240	<b>4TA401K</b> ⑤⑥	<b>4TA401KCW</b> ⑤⑥
400	Aluminum	Cu/Al	500–750 (1)	300–400	<b>2TA402K</b> ②③	—
					<b>3TA402K</b> ②④	—
					<b>4TA402K</b> ⑤⑥	—
400	Copper	Cu	500–750 (1)	—	<b>2T402K</b> ②③	—
					<b>3T402K</b> ②④	—
					<b>4T402K</b> ⑤⑥	—

**Notes**

- ① Individually packed.
- ② Terminal kits contain one terminal for each pole and one terminal cover.
- ③ Two-pole kit.
- ④ Three-pole kit.
- ⑤ Four-pole kit.
- ⑥ Terminal kits contain one terminal for each pole and three interphase barriers.

### Accessories

#### Allowable Accessory Combinations

Different combinations of accessories can be supplied, depending on the types of accessories and the number of poles in the circuit breaker.

#### KD Frame Accessories

Description	Reference Page	Two-Pole <sup>①</sup>		Three-Pole			Four-Pole			Neutral
		Left	Right	Left	Center	Right	Left	Center	Right	
<b>Internal Accessories (Only One Internal Accessory Per Pole)</b>										
Alarm lockout (Make/Break)	V4-T2-276		■	□		□		■		
Alarm lockout (2Make/2Break)	V4-T2-276			□		□		■		
Auxiliary switch (1A, 1B)	V4-T2-278		■	■		■		■		■
Auxiliary switch (2A, 2B)	V4-T2-278			■		■		■		■
Auxiliary switch (3A, 3B)	V4-T2-278			■		■		■		■
Auxiliary switch and alarm switch combination	V4-T2-279			□		□		□		□
Shunt trip—standard <sup>②</sup>	V4-T2-282		■	■		■		■		■
Shunt trip—low energy <sup>②</sup>	V4-T2-285			■		■		■		
Undervoltage release mechanism <sup>②</sup>	V4-T2-290		■	■		■		■		
PowerNet or zone interlock kit (OPTIM 550)	V4-T2-293					■				
<b>External Accessories</b>										
End cap kit	V4-T2-308	●	●	●	●	●	●	●	●	●
Keeper nut	V4-T2-308	●	●	●	●	●	●	●	●	●
Control wire terminal kit	V4-T2-309	●	●	●	●	●	●	●	●	●
Terminal adapter	V4-T2-309	●	●	●	●	●	●	●	●	●
Multewire connectors	V4-T2-310	●	●	●	●	●	●	●	●	●
Rear fed terminals	V4-T2-310	●	●	●	●	●	●	●	●	●
Base mounting hardware	V4-T2-311	●	●	●	●	●	●	●	●	●
Terminal shields	V4-T2-313	●	●	●	●	●	●	●	●	●
Interphase barriers	V4-T2-313	●	●	●	●	●	●	●	●	●
Non-padlockable handle block	V4-T2-314	■			■			■		
Padlockable handle block	V4-T2-314				■					
Padlockable handle lock hasp	V4-T2-315		■	□		□		□		□
Cylinder lock	V4-T2-315	□	□	□		□				
Key Interlock kit	V4-T2-316	■	□	□		□		□		□
Sliding bar interlock—requires two breakers	V4-T2-317			●	●	●				
Walking beam interlock—requires two breakers	V4-T2-317			●	●	●		●	●	●
Electrical (solenoid) operator	V4-T2-318			●	●	●		●	●	●
Plug-in adapters	V4-T2-319	●	●	●	●	●		●	●	●
Rear connecting studs	V4-T2-321	●	●	●	●	●		●	●	●
Panelboard connecting straps	V4-T2-322	●	●	●	●	●		●	●	●
Handle mechanisms	V4-T2-432	●	●	●	●	●		●	●	●
Handle extension	V4-T2-447	●	●	●	●	●		●	●	●
IQ Energy Sentinel	V4-T2-324			●	●	●		●	●	●
Solid-state (electronic) portable test kit	V4-T2-324	●	●	●	●	●		●	●	●
<b>OPTIM System Components Three Poles</b>										
Breaker interface module (BIM)	V4-T2-325									
Digitrip OPTIMizer	V4-T2-325									
Auxiliary power module	V4-T2-325									
<b>Modifications (Refer to Eaton)</b>										
Special calibration	—	●	●	●	●	●		●	●	●
Moisture fungus treatment	V4-T2-116	●	●	●	●	●		●	●	●
Freeze-tested circuit breakers	—	●	●	●	●	●		●	●	●
Marine/naval application	—	●	●	●	●	●		●	●	●

#### Legend

- Applicable in indicated pole position
- May be mounted on left or right pole—not both
- Accessory available/modification available

#### Notes

- ① Two-pole breaker supplied in three-pole frame. Current carrying parts omitted from center pole.
- ② Shunt trip and UVR cannot be mounted in right poles on KES or OPTIM trip units. Standard internal accessories cannot be mounted in right pole on any K-Frame OPTIM trip units. Special OPTIM ground fault and zone interlock accessories are available for field installation in the right pole of K-Frame 550 OPTIM trip units. Factory installed 2a/2b and bell/aux are available for factory installation. K-Frame breakers equipped with OPTIM 1050 trip units include aux-bell alarm in the right pole.

## 310+ Electronic Trip Unit Accessories

Description	Catalog Number
Electronic portable test kit	MTST230V <sup>②</sup>
Trip unit tamper protection wire seal	5108A03H01
External neutral sensor, 400 A	LGFACT400 <sup>③</sup>
External neutral sensor, 250 A	LGFACT250 <sup>③</sup>
External neutral sensor, 125 A	LGFACT125 <sup>③</sup>
Breaker-mount cause-of-trip indication	TRIP-LED
Breaker-mount ammeter module	DIGIVIEW
Remote-mount ammeter module	DIGIVIEWR06 <sup>④</sup>

## Technical Data and Specifications

## NEMA/UL 489/CSA Interrupting Capacity Ratings

Circuit Breaker Type	Number of Poles	Interrupting Capacity (kA Symmetrical Amperes)					Volts DC 250 <sup>⑤⑥</sup>
		Volts AC (50/60 Hz)					
		240	277	480	600		
DK	2, 3	65	—	—	—	10	
KDB	2, 3, 4	65	—	35	25	10	
KD	2, 3, 4	65	—	35	25	10	
HKD, HKDB	2, 3, 4	100	—	65	35	22	
KDC <sup>⑦</sup>	2, 3, 4	200	—	100	65	22	
CKD	3	65	—	35	25	—	
CHKD	3	100	—	65	35	—	

## IEC 157-1 (P1) Interrupting Capacity Ratings

Circuit Breaker Type	Number of Poles	Interrupting Capacity (kA Symmetrical Amperes)					Volts DC 250 <sup>⑤⑥</sup>
		Volts AC (50/60 Hz)					
		240	380	415	440	500	
DK	2, 3	65	—	—	—	10	
KDB	2, 3, 4	65	40	40	—	10	
KD	2, 3, 4	65	40	40	—	10	
HKD, HKDB	2, 3, 4	100	65	65	—	22	
KDC	2, 3, 4	200	100	100	—	22	

## UL 489 Current Limiting Data

Frame	Circuit	I <sub>p</sub> (kA)	I <sup>2</sup> T (10 <sup>6</sup> A <sup>2</sup> S)
KDC	240 V/200 kA	56.00	2.30
KDC	480 V/100 kA	53.30	5.60
KDC	600 V/50 kA	43.40	5.40

## Notes

- ① Two-pole breaker supplied in three-pole frame. Current carrying parts omitted from center pole.
- ② MTST230V applies to 100–230 Vac.
- ③ Included with all LD LSG and LSIG trip units and breakers.
- ④ Includes 6 ft cable for remote mounting; NEMA 3R rated.
- ⑤ Two-pole circuit breaker or two outside poles of three-pole circuit breaker.
- ⑥ Time constant is 3 milliseconds minimum at 10 kA and 8 milliseconds minimum at 22 kA.
- ⑦ Current limiting.

#### 310+ Specifications

Trip Unit Type	Digitrip RMS 310+
<b>Breaker Type</b>	
Frame	K
Frames available	125 A, 250 A, 400 A
Continuous current range (A)	55–400 A
Ground fault pickup (A)	50–400 A
Interrupting capacities at 480 Vac (kAIC)	35, 65, 100
100% rated	Yes
<b>Protection</b>	
Ordering options	LS, LSI, LSG, LSIG, ALSI, ALSIG
Arcflash Reduction Maintenance System	Remote enabled on ALSI, ALSIG
Interchangeable trip unit	Yes
High load alarm, trip (suffix B20) ①	Yes
Ground fault alarm with trip (suffix B21) ①	LSG, LSIG, ALSIG
Ground fault alarm, no trip (suffix B22)	LSG, LSIG, ALSIG
Zone selective interlock (suffix ZG) ①	LSI, LSIG, ALSI, ALSIG
Cause of trip indication	Yes (via TRIP-LED or DIGVIEW)
Thru-cover accessories	No

#### 310+ Adjustability Specifications

310+ Settings	K-Frame			
	125A	250 A	400 A	
$I_r \setminus I_n$				
$I_r =$ continuous current or long delay pickup (amperes) (All 310+)	A (=I <sub>r</sub> )	55	100	160
	B (=I <sub>r</sub> )	60	125	200
	C (=I <sub>r</sub> )	70	150	225
	D (=I <sub>r</sub> )	80	160	250
	E (=I <sub>r</sub> )	90	175	300
	F (=I <sub>r</sub> )	100	200	315
	G (=I <sub>r</sub> )	110	225	350
	H (=I <sub>r</sub> =I <sub>n</sub> )	125	250	400
$t_r =$ long delay time (seconds) (All 310+)				
	2	2	2	2
	4	4	4	4
	7	7	7	7
	10	10	10	10
	12	12	12	12
	15	15	15	15
	20	20	20	20
	24	24	24	24
$I_{sd} (x I_r) =$ short delay pickup (amperes) (All 310+)				
	Position 1	2	2x	2x
	Position 2	3	3x	3x
	Position 3	4	4x	4x
	Position 4	5	5x	5x
	Position 5	6	6x	6x
	Position 6	7	7x	7x
	Position 7	8	8x	8x
	Position 8	10	10x	10x
	Position 9	12	12x	12x
$t_{sd} =$ short delay time I <sup>2</sup> t (milliseconds) (LS and LSG)	Fixed	67 @10x		
$t_{sd} =$ short delay time flat (milliseconds) (LSI, LSIG, ALSI, ALSIG)				
	Position 1	Inst		
	Position 2	120		
	Position 3	300		
$I_g (x I_n) =$ ground fault pickup (amperes) (LSG, LSIG, ALSIG)				
	Position 1	25	50	80
	Position 2	37.5	75	120
	Position 3	50	100	160
	Position 4	75	150	240
	Position 5	100	200	320
	Position 6	125	250	400
$t_g =$ ground fault delay time (milliseconds) (LSG, LSIG, ALSIG)				
	Position 1	Inst		
	Position 2	120		
	Position 3	300		
Independently adjustable Instantaneous (I <sub>i</sub> ) setting ②				
Maintenance Mode pickup (2.5 x I <sub>n</sub> ) (amperes) (310+ with Maintenance Mode—ALSI and ALSIG)	Fixed	312	625	1000

#### Notes

① B2x suffixes cannot be combined with B2x suffixes.

② Not available for KD. Independently adjustable I<sub>i</sub> setting available in LG, NG and RG ALSI and ALSIG trip units.

## Specifications

Trip Unit Type	Digitrip OPTIM 550	Digitrip OPTIM 1050
rms sensing	Yes	Yes
<b>Breaker Type</b>		
Frame	K	K
Ampere range	125–400 A	125–400 A
Interrupting rating at 480 volts	35, 65, 100 (kA)	35, 65, 100 (kA)
<b>Protection</b>		
Ordering options	LSI, LSI(A), LSIG	LSI(A), LSIG
Fixed rated plug ( $I_n$ )	Yes	Yes
Overtemperature trip	Yes	Yes
<b>Long Delay Protection (L)</b>		
Adjustable rating plug ( $I_n$ )	No	No
Long delay pickup	0.4–1.0 x ( $I_n$ )	0.4–1.0 x ( $I_n$ )
Long delay time $I^2t$	2–24 seconds	2–24 seconds
Long delay time $I^4t$	1–5 seconds	1–5 seconds
Long delay thermal memory	Yes	Yes
High load alarm	0.5–1.0 x $I_r$	0.5–1.0 x $I_r$
<b>Short Delay Protection (S)</b>		
Short delay pickup	150–800% x ( $I_r$ )	150–800% x ( $I_r$ )
Short delay time $I^2t$	100–500 ms	100–500 ms
Short delay time flat	100–500 ms	100–500 ms
Short delay time zone selective interlocking	Yes <sup>①</sup>	Yes
<b>Instantaneous Protection (I)</b>		
Instantaneous pickup	200–800% x ( $I_n$ )	200–800% x ( $I_n$ )
Discriminator	Yes	Yes
Instantaneous override	Yes	Yes
<b>Ground Fault Protection (G)</b>		
Ground fault alarm	20–100% x ( $I_g$ )	20–100% x ( $I_g$ )
Ground fault pickup	20–100% x ( $I_g$ )	20–100% x ( $I_g$ )
Ground fault delay $I^2t$	100–500 ms	100–500 ms
Ground fault delay flat	100–500 ms	100–500 ms
Ground fault zone selective interlocking	Yes <sup>①</sup>	Yes
Ground fault thermal memory	Yes	Yes
<b>System Diagnostics</b>		
Status LEDs	Yes	Yes
Cause of trip LEDs	Yes	Yes
Magnitude of trip information	Yes	Yes
Remote signal contact—ground alarm	Yes <sup>①</sup>	Yes
Local auxiliary and bell alarm contact	Optional	Included
<b>System Monitoring</b>		
Digital display	Yes <sup>②</sup>	Yes <sup>②</sup>
Current	Yes	Yes
Power and energy	No	Yes
Power quality—harmonics	No	Yes
Power factor	No	Yes
<b>Communications</b>		
PowerNet	Yes <sup>③</sup>	Yes
<b>Testing</b>		
Testing method	OPTIMizer, BIM, PowerNet	OPTIMizer, BIM, PowerNet

## Legend

BIM = Breaker Interface Module  
(A) = GF Alarm  
 $I_g$  = Sensor Rating  
 $I_n$  = Rating Plug  
 $I_r$  = Long Delay Pickup Setting

## Notes

- ① Zone interlock kit.  
② By OPTIMizer/BIM.  
③ Eaton's PowerNet kit.

# 2.3

## Molded Case Circuit Breakers

### Series C

#### Dimensions and Weights

Approximate Dimensions in Inches (mm)

2

#### KD Frame

Number of Poles	Width	Height	Depth
2, 3	5.50 (149.7)	10.13 (257.3)	4.10 (104.1)
4	7.22 (183.4)	10.13 (257.3)	4.10 (104.1)

#### KD-Frame, Two- and Three-Pole

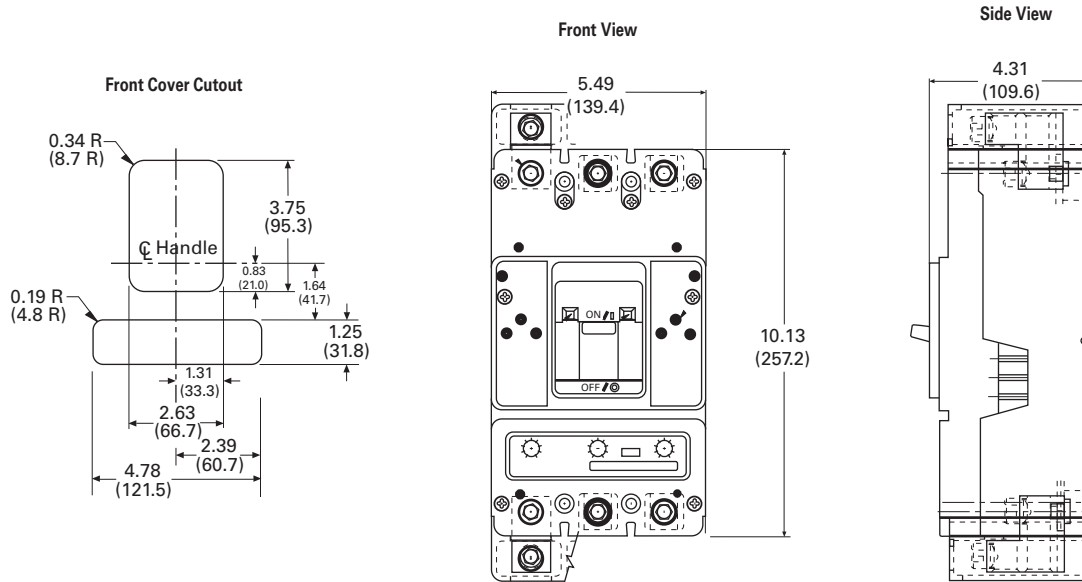

Approximate Shipping Weight, Lbs (kg)

#### KD Frame

Breaker Type	Complete Breaker		Frame Only		Trip Unit ①	
	Two-Pole	Three-Pole	Two-Pole	Three-Pole	Two-Pole	Three-Pole
DK	10.0 (4.5)	11.5 (5.2)	—	—	—	—
KDB	10.0 (4.5)	11.5 (5.2)	—	—	—	—
KD	10.0 (4.5)	11.5 (5.2)	7.5 (3.4)	8.5 (3.9)	1.5 (0.7)	1.5 (0.7)
HKD, HKDB	10.0 (4.5)	11.5 (5.2)	7.5 (3.4)	8.5 (3.9)	1.5 (0.7)	1.5 (0.7)
KDC	10.0 (4.5)	11.5 (5.2)	7.5 (3.4)	8.5 (3.9)	1.5 (0.7)	1.5 (0.7)

#### Note

① Weights shown are for thermal-magnetic trip units. Three-pole electronic trip units weigh 2.5 lbs (1.1 kg).

Typical L-Frame Circuit Breaker



## Contents

<i>Description</i>	<i>Page</i>
Product Overview . . . . .	V4-T2-116
Standards and Certifications . . . . .	V4-T2-117
Quick Reference . . . . .	V4-T2-118
G-Frame (15–100 Amperes) . . . . .	V4-T2-121
F-Frame (10–225 Amperes) . . . . .	V4-T2-135
J-Frame (70–250 Amperes) . . . . .	V4-T2-153
K-Frame (70–400 Amperes) . . . . .	V4-T2-161
L-Frame (125–600 Amperes)	
Catalog Number Selection . . . . .	V4-T2-186
Product Selection . . . . .	V4-T2-188
Accessories . . . . .	V4-T2-204
Technical Data and Specifications . . . . .	V4-T2-206
Dimensions and Weights . . . . .	V4-T2-210
M-Frame (300–800 Amperes) . . . . .	V4-T2-211
N-Frame (400–1200 Amperes) . . . . .	V4-T2-222
R-Frame (800–2500 Amperes) . . . . .	V4-T2-237
Motor Circuit Protectors (MCP) . . . . .	V4-T2-256
Motor Protection Circuit Breakers (MPCB) . . . . .	V4-T2-267
Type ELC Current Limiter Attachment (Size 0–4) . . . . .	V4-T2-269
Current Limiting Circuit Breaker Module . . . . .	V4-T2-270
Internal Accessories . . . . .	V4-T2-273
External Accessories . . . . .	V4-T2-304

## L-Frame (125–600 Amperes)

### Product Description

- All Eaton L-Frame circuit breakers are HACR rated
- L-Frame circuit breakers are available as individual components (frame, trip unit, terminals), or factory assembled complete breakers
- L-Frame circuit breakers with non-interchangeable trip units are suitable for reverse feed use

### Standards and Certifications

- CE marked



# 2.3

## Molded Case Circuit Breakers

### Series C

2

#### Catalog Number Selection

This information is presented only as an aid to understanding catalog numbers. It is not to be used to build catalog numbers for circuit breakers or trip units.

#### LD-Frame with Thermal-Magnetic Trip Unit Technology

##### Thermal-Magnetic Breakers and Frame ①

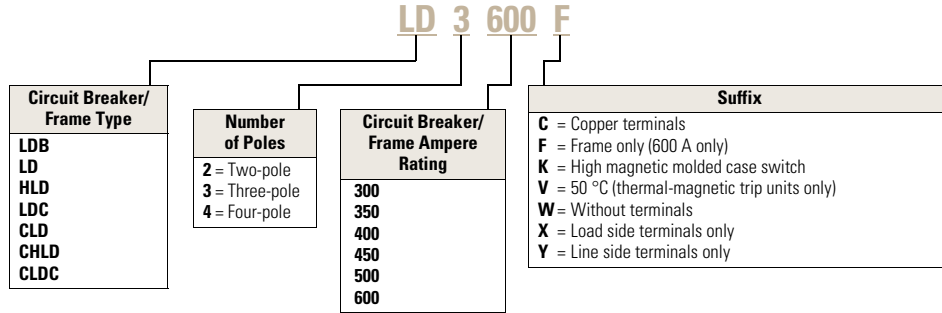

##### Thermal-Magnetic Trip Unit ①

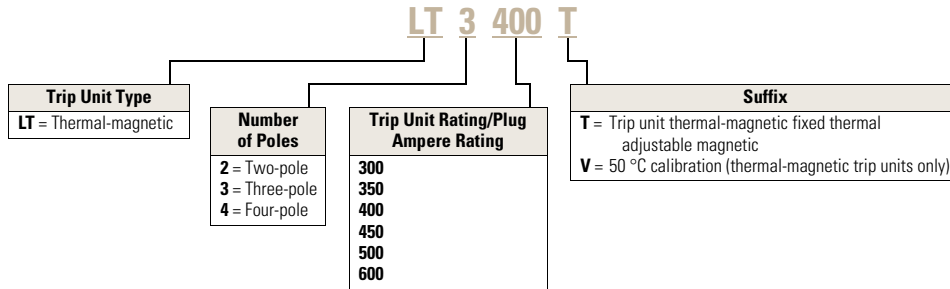

#### Note

① Frames are the same for thermal-magnetic or 310+ electronic trip units, e.g., **LD3600F**, **HLD3600F**, etc.

**LD-Frame with 310+ Electronic Trip Unit Technology**

**310+ Circuit Breakers**

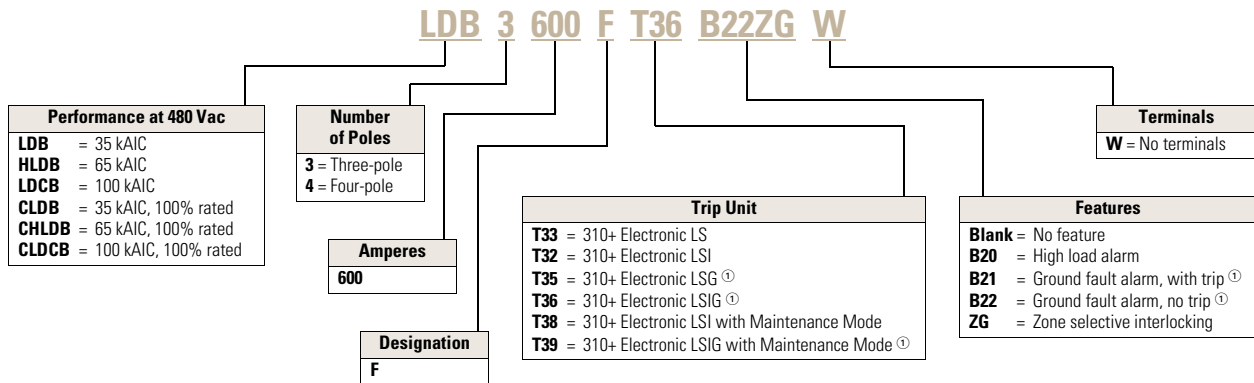

**310+ Electronic Trip Units <sup>②</sup>**

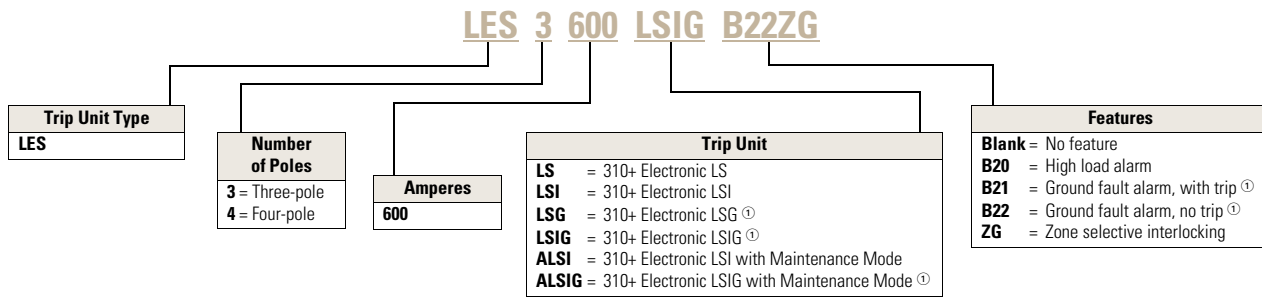

**LD-Frame with OPTIM Electronic Trip Unit Technology**

**OPTIM Circuit Breakers**

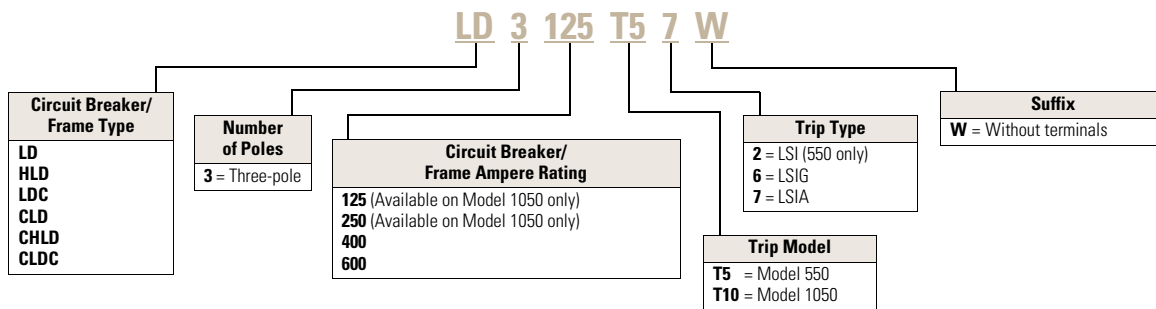

**Notes**

- ① Not available in four-pole configurations.
- ② Frames are the same for thermal-magnetic or 310+ electronic trip units, e.g., **LD3600F**, **HLD3600F**, etc.

## Product Selection

2

## Types LD, HLD and LDC Thermal-Magnetic Circuit Breakers with Interchangeable Trip Units

Maximum Continuous Ampere Rating at 40 °C ①	Standard Interrupting Capacity 600 Vac Rated 35 kAIC at 480 Vac	High Interrupting Capacity 600 Vac Rated 65 kAIC at 480 Vac	Ultra High Interrupting Capacity Current Limiting 600 Vac Rated 100 kAIC at 480 Vac	Thermal-Magnetic Trip Unit Only	Standard Terminals Only
	Factory Assembled Circuit Consisting of Frame, Trip Unit and Terminals Catalog Number	Factory Assembled Circuit Consisting of Frame, Trip Unit and Terminals Catalog Number	Factory Assembled Circuit Consisting of Frame, Trip Unit and Terminals Catalog Number	For Use with Standard or High or Ultra High Interrupting Frames Catalog Number	See Page V4-T2-203 for Optional Terminals Catalog Number
<b>Two-Pole</b>					
300	LD2300	HLD2300	LDC2300	LT2300T	TA602LD ②
350	LD2350	HLD2350	LDC2350	LT2350T	TA602LD ②
400	LD2400	HLD2400	LDC2400	LT2400T	TA602LD ②
450	LD2450	HLD2450	LDC2450	LT2450T	TA602LD ②
500	LD2500	HLD2500	LDC2500	LT2500T	TA602LD ②
600	LD2600	HLD2600	LDC2600	LT2600T	2TA603LDK ③
<b>Three-Pole</b>					
300	LD3300	HLD3300	LDC3300	LT3300T	TA602LD ②
350	LD3350	HLD3350	LDC3350	LT3350T	TA602LD ②
400	LD3400	HLD3400	LDC3400	LT3400T	TA602LD ②
450	LD3450	HLD3450	LDC3450	LT3450T	TA602LD ②
500	LD3500	HLD3500	LDC3500	LT3500T	TA602LD ②
600	LD3600	HLD3600	LDC3600	LT3600T	3TA603LDK ③
<b>Four-Pole ④</b>					
300	LD4300	HLD4300	LDC4300	LT4300T	TA602LD ②
350	LD4350	HLD4350	LDC4350	LT4350T	TA602LD ②
400	LD4400	HLD4400	LDC4400	LT4400T	TA602LD ②
450	LD4450	HLD4450	LDC4450	LT4450T	TA602LD ②
500	LD4500	HLD4500	LDC4500	LT4500T	TA602LD ②
600	LD4600	HLD4600	LDC4600	LT4600T	4TA603LDK ③

## Types LD, HLD and LDC Thermal-Magnetic Circuit Breakers—Frame Only

Standard Interrupting Capacity 600 Vac Rated 35 kAIC at 480 Vac Catalog Number	High Interrupting Capacity 600 Vac Rated 65 kAIC at 480 Vac Catalog Number	Ultra High Interrupting Capacity Current Limiting 600 Vac Rated 100 kAIC at 480 Vac Catalog Number
<b>Two-Pole</b>		
LD2600F	HLD2600F	LDC2600F
<b>Three-Pole</b>		
LD3600F	HLD3600F	LDC3600F
<b>Four-Pole</b>		
LD4600F	HLD4600F	LDC4600F

## Notes

- ① Magnetic trip range 5–10 times continuous ampere rating.
- ② Individually packed.
- ③ Terminal kits contain one terminal for each pole and one terminal cover.
- ④ Neutral is in right pole.

**Types LD, HLD and LDC Electronic Circuit Breakers with Interchangeable Trip Units**

Order as individual components: breaker frame, trip unit and terminals. See 310+ adjustability specifications on **Page V4-T2-182**.

**Types LD, HLD and LDC Electronic Circuit Breakers with Interchangeable 310+ Trip Units**

Maximum Continuous Ampere Rating at 40 °C	Circuit Breaker Frame Only			Digitrip RMS 310+ Trip Unit Only ①				Neutral CT for LSG and LSI ②③	Terminal Information
	Standard Interrupting Capacity 600 Vac Rated 35 kAIC at 480 Vac Catalog Number	High Interrupting Capacity 600 Vac Rated 65 kAIC at 480 Vac	Ultra High Interrupting Capacity Current Limiting 600 Vac Rated 100 kAIC at 480 Vac	Standard LS	Optional LSI	LSG	LSIG		
				Adjustable Short Time Pickup with I <sup>2</sup> t Short Delay Ramp	Independently Adjustable Short Time Pickup and Delay	Adjustable Short Time Pickup with I <sup>2</sup> t Short Delay and Ground Fault Protection	Independently Adjustable Short Time Pickup and Ground Fault Protection		
<b>Three-Pole</b>									
600	LD3600F	HLD3600F	LDC3600F	LES3600LS	LES3600LSI	LES3600LSG	LES3600LSIG	LGFACT600	See Page V4-T2-180
<b>Four-Pole ④</b>									
600	LD4600F	HLD4600F	LDC4600F	LES4600LS	LES4600LSI	—	—	—	See Page V4-T2-180

**Types LDB, HLDB and LDCB Electronic Circuit Breakers with Non-Interchangeable 310+ Electronic Trip Units Suitable for Reverse Feed**

See 310+ adjustability specifications on **Page V4-T2-182**.

**Circuit Breaker Frame Including Digitrip RMS 310+ Electronic Trip Unit Less Terminals  
Types LDB, HLDB and LDCB with Digitrip 310+ Non-Interchangeable Trip Units**

Maximum Continuous Ampere Rating at 40 °C	Number of Poles	Factory Assembled Circuit Breaker Consisting of Frame and Trip Unit Less Terminals ①				Neutral CT for LSG and LSI ②③	Terminal Information
		Standard LS	Optional LSI	LSG	LSIG		
		Adjustable Short Time Pickup with I <sup>2</sup> t Short Delay Ramp Catalog Number	Independently Adjustable Short Time Pickup and Delay	Adjustable Short Time Pickup with I <sup>2</sup> t Short Delay and Ground Fault Protection	Independently Adjustable Short Time Pickup and Ground Fault Protection		
600	3	LDB3600FT33W	LDB3600FT32W	LDB3600FT35W	LDB3600FT36W	LGFACT600	See Page V4-T2-180
600	3	HLDB3600FT33W	HLDB3600FT32W	HLDB3600FT35W	HLDB3600FT36W		
600	3	LDCB3600FT33W	LDCB3600FT32W	LDCB3600FT35W	LDCB3600FT36W		

**100% Rated Types CLD, CHLD and CLDC Electronic Circuit Breakers with Interchangeable Trip Units**

The NEC allows the breaker to be rated at 100% of its frame size in an assembly, provided that 90 °C wire is applied at the 75 °C ampacity. All 100% rated circuit breakers have electronic trip units. Order as individual components: breaker frame, trip unit and terminals. See 310+ adjustability specifications on **Page V4-T2-182**.

**100% Rated Types CLD, CHLD and CLDC Electronic Circuit Breakers with 310+ Interchangeable Trip Units**

Maximum Continuous Ampere Rating at 40 °C	Circuit Breaker Frame Only			Digitrip RMS 310+ Trip Unit Only				Neutral CT for LSG and LSI ②③	Terminal Information
	Standard Interrupting Capacity 600 Vac Rated 35 kAIC at 480 Vac Catalog Number	High Interrupting Capacity 600 Vac Rated 65 kAIC at 480 Vac	Ultra High Interrupting Capacity Current Limiting 600 Vac Rated 100 kAIC at 480 Vac	Standard LS	Optional LSI	LSG	LSIG		
				Adjustable Short Time Pickup with I <sup>2</sup> t Short Delay Ramp	Independently Adjustable Short Time Pickup and Delay	Adjustable Short Time Pickup with I <sup>2</sup> t Short Delay and Ground Fault Protection	Independently Adjustable Short Time Pickup and Ground Fault Protection		
<b>Three-Pole</b>									
600	CLD3600F	CHLD3600F	CLDC3600F	LES3600LS	LES3600LSI	LES3600LSG	LES3600LSIG	LGFACT600	See Page V4-T2-180

**Notes**

- ① For AC use only.
- ② Required for four-wire systems if neutral protection is desired.
- ③ Included with LSG and LSI trip units.
- ④ Neutral is in right pole.

### Type LDB Thermal-Magnetic Circuit Breakers with Non-Interchangeable Trip Units <sup>①</sup>

Maximum Continuous Ampere Rating	600 Vac Rated, 250 Vdc Complete Circuit Breaker	
	Without Line and Load Terminals Catalog Number	With Standard Line and Load Terminals Only Catalog Number
<b>Two-Pole</b>		
300	LDB2300W	LDB2300
350	LDB2350W	LDB2350
400	LDB2400W	LDB2400
450	LDB2450W	LDB2450
500	LDB2500W	LDB2500
600	LDB2600W	LDB2600
<b>Three-Pole</b>		
300	LDB3300W	LDB3300
350	LDB3350W	LDB3350
400	LDB3400W	LDB3400
450	LDB3450W	LDB3450
500	LDB3500W	LDB3500
600	LDB3600W	LDB3600

### Molded Case Switches

Eaton's molded case switches are used as compact switches in applications requiring high current switching capabilities. Molded case switches are constructed of circuit breaker

components and are of the high instantaneous automatic type. Molded case switches are listed in accordance with Underwriters Laboratories Standard UL 489.

### Molded Case Switches

Maximum Continuous Ampere Rating at 40 °C	600 Vac Maximum, 250 Vdc Circuit Breaker Only without Line and Load Terminals	
	Catalog Number	Standard Terminals Only See Page V4-T2-203 for Optional Terminals Catalog Number
<b>Two-Pole</b>		
600	LD2600WK	2TA603LDK
600	LDB2600WK <sup>①</sup>	2TA603LDK
600	HLD2600WK	2TA603LDK
<b>Three-Pole</b>		
600	LD3600WK	3TA603LDK
600	LDB3600WK <sup>①</sup>	3TA603LDK
600	HLD3600WK	3TA603LDK
<b>Four-Pole</b>		
600	LD4600WK	4TA603LDK
600	LDB4600WK <sup>①</sup>	4TA603LDK
600	HLD4600WK	4TA603LDK

#### Notes

<sup>①</sup> Factory sealed—suitable for reverse feed application.

Molded case switch will trip above 6000 amperes.

**Digitrip OPTIM Electronic Circuit Breaker with Interchangeable Rating Plug**

Order as individual components: Breaker Frame (which includes Trip Unit), Rating Plug, Terminals.

**Digitrip OPTIM 550 Electronic Circuit Breaker with Interchangeable Rating Plug**

Maximum Continuous Ampere Rating at 40 °C	Circuit Breaker Frame Only			Digitrip OPTIM Rating Plug Only	
	LSI Catalog Number	LSIG Catalog Number	LSIA Catalog Number	Ampere Rating	Fixed Rating Plug Catalog Number
<b>Three-Pole Standard Interrupting Capacity 600 Vac Rated 35 kAIC at 480 Vac</b>					
125	LD3125T52W	LD3125T56W	LD3125T57W	—	ORPL125A070
				—	ORPL125A090
				—	ORPL125A100
				—	ORPL125A110
				—	ORPL125A125
250	LD3250T52W	LD3250T56W	LD3250T57W	—	ORPL025A125
				—	ORPL025A150
				—	ORPL025A175
				—	ORPL025A200
				—	ORPL025A225
400	LD3400T52W	LD3400T56W	LD3400T57W	200	ORPL40A200
				225	ORPL40A225
				250	ORPL40A250
				300	ORPL40A300
				350	ORPL40A350
				400	ORPL40A400
600	LD3600T52W	LD3600T56W	LD3600T57W	300	ORPL60A300
				350	ORPL60A350
				400	ORPL60A400
				500	ORPL60A500
				600	ORPL60A600

**Notes**① Long delay I<sup>4</sup>t response selection limits short delay time to flat response.② Zone interlocking, PowerNet, or both features can be added at the factory by adding suffixes **ZG**, **PN** or **ZGP** respectively to above catalog number.

## Digitrip OPTIM 550 Electronic Circuit Breaker with Interchangeable Rating Plug, continued

Maximum Continuous Ampere Rating at 40 °C	Circuit Breaker Frame Only			Digitrip OPTIM Rating Plug Only	
	LSI Catalog Number	LSIG Catalog Number	LSIA Catalog Number	Ampere Rating	Fixed Rating Plug Catalog Number
	L – Adjustable Long Delay Pickup ( $I_L$ ) with Adjustable Long Delay Time ( $I^2t$ or $I^4t$ Response) <sup>①</sup> S – Adjustable Short Delay Pickup with Adjustable Short Delay Time ( $I^2t$ or Flat Response) I – Adjustable Instantaneous Pickup G – Adjustable Ground Fault Pickup with Adjustable Ground Fault Time ( $I^2t$ or Flat Response) A – Adjustable Ground Fault Alarm with Adjustable Ground Fault Time ( $I^2t$ or Flat Response) OPTIM 550 <sup>②</sup>				
<b>Three-Pole High Interrupting Capacity 600 Vac Rated 65 kAIC at 480 Vac</b>					
125	HLD3125T52W	HLD3125T56W	HLD3125T57W	70	ORPL125A070
				90	ORPL125A090
				100	ORPL125A100
				110	ORPL125A110
				125	ORPL125A125
250	HLD3250T52W	HLD3250T56W	HLD3250T57W	125	ORPL025A125
				150	ORPL025A150
				175	ORPL025A175
				200	ORPL025A200
				225	ORPL025A225
400	HLD3400T52W	HLD3400T56W	HLD3400T57W	200	ORPL40A200
				225	ORPL40A225
				250	ORPL40A250
				300	ORPL40A300
				350	ORPL40A350
600	HLD3600T52W	HLD3600T56W	HLD3600T57W	400	ORPL60A400
				300	ORPL60A300
				350	ORPL60A350
				400	ORPL60A400
				500	ORPL60A500
				600	ORPL60A600

**Notes**

<sup>①</sup> Long delay  $I^4t$  response selection limits short delay time to flat response.

<sup>②</sup> Zone interlocking, PowerNet, or both features can be added at the factory by adding suffixes **ZG**, **PN** or **ZGP** respectively to above catalog number.

## Digitrip OPTIM 550 Electronic Circuit Breaker with Interchangeable Rating Plug, continued

Maximum Continuous Ampere Rating at 40 °C	Circuit Breaker Frame Only			Digitrip OPTIM Rating Plug Only	
	LSI Catalog Number	LSIG Catalog Number	LSIA Catalog Number	Ampere Rating	Fixed Rating Plug Catalog Number
	L – Adjustable Long Delay Pickup ( $I_t$ ) with Adjustable Long Delay Time ( $I^2t$ or $I^4t$ Response) <sup>①</sup> S – Adjustable Short Delay Pickup with Adjustable Short Delay Time ( $I^2t$ or Flat Response) I – Adjustable Instantaneous Pickup G – Adjustable Ground Fault Pickup with Adjustable Ground Fault Time ( $I^2t$ or Flat Response) A – Adjustable Ground Fault Alarm with Adjustable Ground Fault Time ( $I^2t$ or Flat Response)				
	OPTIM 550 <sup>②</sup>				
<b>Three-Pole Ultra High Interrupting Capacity Current Limiting 600 Vac Rated 100 kAIC at 480 Vac</b>					
125	LDC3125T52W	LDC3125T56W	LDC3125T57W	—	ORPL125A070
				—	ORPL125A090
				—	ORPL125A100
				—	ORPL125A110
				—	ORPL125A125
250	LDC3250T52W	LDC3250T56W	LDC3250T57W	—	ORPL025A125
				—	ORPL025A150
				—	ORPL025A175
				—	ORPL025A200
				—	ORPL025A225
400	LDC3400T52W	LDC3400T56W	LDC3400T57W	200	ORPL40A200
				225	ORPL40A225
				250	ORPL40A250
				300	ORPL40A300
				350	ORPL40A350
600	LDC3600T52W	LDC3600T56W	LDC3600T57W	400	ORPL40A400
				300	ORPL60A300
				350	ORPL60A350
				400	ORPL60A400
				500	ORPL60A500
				600	ORPL60A600

**Notes**

<sup>①</sup> Long delay  $I^4t$  response selection limits short delay time to flat response.

<sup>②</sup> Zone interlocking, PowerNet, or both features can be added at the factory by adding suffixes **ZG**, **PN** or **ZGP** respectively to above catalog number.

**Digitrip OPTIM Electronic Circuit Breaker with Interchangeable Rating Plug**

Order as individual components: Breaker Frame (which includes Trip Unit), Rating Plug, Terminals.

2

**Digitrip OPTIM 1050 Electronic Circuit Breaker with Interchangeable Rating Plug****Circuit Breaker Frame Only****L** – Adjustable Long Delay Pickup ( $I_L$ ) with Adjustable Long Delay Time ( $I^2t$  or  $I^4t$  Response) ①**S** – Adjustable Short Delay Pickup with Adjustable Short Delay Time ( $I^2t$  or Flat Response)**I** – Adjustable Instantaneous Pickup**G** – Adjustable Ground Fault Pickup with Adjustable Ground Fault Time ( $I^2t$  or Flat Response)**A** – Adjustable Ground Fault Alarm with Adjustable Ground Fault Time ( $I^2t$  or Flat Response)**OPTIM 1050** ②③**Digitrip OPTIM Rating Plug Only****Maximum  
Continuous  
Ampere  
Rating  
at 40 °C****LSIG****Catalog  
Number****LSIA****Catalog  
Number****Ampere  
Rating****Fixed Rating Plug  
Catalog  
Number****Three-Pole Standard Interrupting Capacity 600 Vac Rated 35 kAIC at 480 Vac**

Maximum Continuous Ampere Rating at 40 °C	LSIG Catalog Number	LSIA Catalog Number	Ampere Rating	Fixed Rating Plug Catalog Number
125	LD3125T106W	LD3125T107W	70	ORPL125A070
			90	ORPL125A090
			100	ORPL125A100
			110	ORPL125A110
			125	ORPL125A125
250	LD3250T106W	LD3250T107W	125	ORPL025A125
			150	ORPL025A150
			175	ORPL025A175
			200	ORPL025A200
			225	ORPL025A225
			250	ORPL025A250
400	LD3400T106W	LD3400T107W	200	ORPL40A200
			225	ORPL40A225
			250	ORPL40A250
			300	ORPL40A300
			350	ORPL40A350
			400	ORPL40A400
			600	ORPL60A600
600	LD3600T106W	LD3600T107W	300	ORPL60A300
			350	ORPL60A350
			400	ORPL60A400
			500	ORPL60A500
			600	ORPL60A600

**Notes**① Long delay  $I^4t$  response selection limits short delay time to flat response.

② One Form C auxiliary switch and one Form C bell alarm switch supplied with breaker as standard.

③ Factory sealed.

## Digitrip OPTIM 1050 Electronic Circuit Breaker with Interchangeable Rating Plug, continued

Maximum Continuous Ampere Rating at 40 °C	Circuit Breaker Frame Only		Digitrip OPTIM Rating Plug Only	
	LSIG Catalog Number	LSIA Catalog Number	Ampere Rating	Fixed Rating Plug Catalog Number
<b>Three-Pole High Interrupting Capacity 600 Vac Rated 65 kAIC at 480 Vac</b>				
125	HLD3125T106W	HLD3125T107W	70	ORPL125A070
			90	ORPL125A090
			100	ORPL125A100
			110	ORPL125A110
			125	ORPL125A125
250	HLD3250T106W	HLD3250T107W	125	ORPL025A125
			150	ORPL025A150
			175	ORPL025A175
			200	ORPL025A200
			225	ORPL025A225
400	HLD3400T106W	HLD3400T107W	250	ORPL025A250
			200	ORPL40A200
			225	ORPL40A225
			250	ORPL40A250
			300	ORPL40A300
600	HLD3600T106W	HLD3600T107W	350	ORPL40A350
			400	ORPL40A400
			300	ORPL60A300
			350	ORPL60A350
			400	ORPL60A400
			500	ORPL60A500
			600	ORPL60A600

**Notes**

- ① Long delay I<sup>4</sup>t response selection limits short delay time to flat response.  
 ② One Form C auxiliary switch and one Form C bell alarm switch supplied with breaker as standard.  
 ③ Factory sealed.

## Digitrip OPTIM 1050 Electronic Circuit Breaker with Interchangeable Rating Plug, continued

Maximum Continuous Ampere Rating at 40 °C	Circuit Breaker Frame Only		Digitrip OPTIM Rating Plug Only	
	LSIG Catalog Number	LSIA Catalog Number	Ampere Rating	Fixed Rating Plug Catalog Number
	<b>OPTIM 1050</b> ②③			
	<b>L – Adjustable Long Delay Pickup (I<sub>L</sub>) with Adjustable Long Delay Time (I<sup>2</sup>t or I<sup>4</sup>t Response) ①</b>			
	<b>S – Adjustable Short Delay Pickup with Adjustable Short Delay Time (I<sup>2</sup>t or Flat Response)</b>			
	<b>I – Adjustable Instantaneous Pickup</b>			
	<b>G – Adjustable Ground Fault Pickup with Adjustable Ground Fault Time (I<sup>2</sup>t or Flat Response)</b>			
	<b>A – Adjustable Ground Fault Alarm with Adjustable Ground Fault Time (I<sup>2</sup>t or Flat Response)</b>			
	<b>Three-Pole Ultra High Interrupting Capacity Current Limiting 600 Vac Rated 100 kAIC at 480 Vac</b>			
125	LDC3125T106W	LDC3125T107W	70	ORPL125A070
			90	ORPL125A090
			100	ORPL125A100
			110	ORPL125A110
			125	ORPL125A125
250	LDC3250T106W	LDC3250T107W	125	ORPL025A125
			150	ORPL025A150
			175	ORPL025A175
			200	ORPL025A200
			225	ORPL025A225
400	LDC3400T106W	LDC3400T107W	250	ORPL025A250
			200	ORPL40A200
			225	ORPL40A225
			250	ORPL40A250
			300	ORPL40A300
600	LDC3600T106W	LDC3600T107W	350	ORPL40A350
			400	ORPL40A400
			300	ORPL60A300
			350	ORPL60A350
			400	ORPL60A400
			500	ORPL60A500
			600	ORPL60A600

**Notes**

- ① Long delay I<sup>4</sup>t response selection limits short delay time to flat response.  
 ② One Form C auxiliary switch and one Form C bell alarm switch supplied with breaker as standard.  
 ③ Factory sealed.

**100% Rated Digitrip OPTIM Circuit Breakers with Interchangeable Rating Plug**

Order as individual components: Breaker Frame (which includes Trip Unit), Rating Plug, Terminals.

**100% Rated Digitrip OPTIM 550 Circuit Breakers with Interchangeable Rating Plug**

**Circuit Breaker Frame Only**

- L – Adjustable Long Delay Pickup ( $I_L$ ) with Adjustable Long Delay Time ( $I^2t$  or  $I^4t$  Response) ①
- S – Adjustable Short Delay Pickup with Adjustable Short Delay Time ( $I^2t$  or Flat Response)
- I – Adjustable Instantaneous Pickup
- G – Adjustable Ground Fault Pickup with Adjustable Ground Fault Time ( $I^2t$  or Flat Response)
- A – Adjustable Ground Fault Alarm with Adjustable Ground Fault Time ( $I^2t$  or Flat Response)

**OPTIM 550 ②**

**Digitrip OPTIM Rating Plug Only**

Maximum Continuous Ampere Rating at 40 °C	LSI Catalog Number	LSIG Catalog Number	LSIA Catalog Number	Ampere Rating	Fixed Rating Plug Catalog Number
<b>Three-Pole Standard Interrupting Capacity 600 Vac Rated 35 kAIC at 480 Vac</b>					
125	CLD3125T52W	CLD3125T56W	CLD3125T57W	70	ORPL125A070
				90	ORPL125A090
				100	ORPL125A100
				110	ORPL125A110
				125	ORPL125A125
250	CLD3250T52W	CLD3250T56W	CLD3250T57W	125	ORPL025A125
				150	ORPL025A150
				175	ORPL025A175
				200	ORPL025A200
				225	ORPL025A225
				250	ORPL025A250
400	CLD3400T52W	CLD3400T56W	CLD3400T57W	200	ORPL40A200
				225	ORPL40A225
				250	ORPL40A250
				300	ORPL40A300
				350	ORPL40A350
				400	ORPL40A400
				600	ORPL60A600
600	CLD3600T52W	CLD3600T56W	CLD3600T57W	300	ORPL60A300
				350	ORPL60A350
				400	ORPL60A400
				500	ORPL60A500
				600	ORPL60A600

**Notes**

- ① Long delay  $I^4t$  response selection limits short delay time to flat response.
- ② Zone interlocking, PowerNet, or both features can be added at the factory by adding suffixes **ZG**, **PN** or **ZGP** respectively to above catalog number.

#### 100% Rated Digitrip OPTIM 550 Circuit Breakers with Interchangeable Rating Plug, continued

Maximum Continuous Ampere Rating at 40 °C	Circuit Breaker Frame Only			Digitrip OPTIM Rating Plug Only	
	LSI Catalog Number	LSIG Catalog Number	LSIA Catalog Number	Ampere Rating	Fixed Rating Plug Catalog Number
	<b>OPTIM 550</b> <sup>②</sup> L – Adjustable Long Delay Pickup (I <sub>1</sub> ) with Adjustable Long Delay Time (I <sup>2</sup> t or I <sup>4</sup> t Response) <sup>①</sup> S – Adjustable Short Delay Pickup with Adjustable Short Delay Time (I <sup>2</sup> t or Flat Response) I – Adjustable Instantaneous Pickup G – Adjustable Ground Fault Pickup with Adjustable Ground Fault Time (I <sup>2</sup> t or Flat Response) A – Adjustable Ground Fault Alarm with Adjustable Ground Fault Time (I <sup>2</sup> t or Flat Response)				
<b>Three-Pole High Interrupting Capacity 600 Vac Rated 65 kAIC at 480 Vac</b>					
125	CHLD3125T52W	CHLD3125T56W	CHLD3125T57W	70	ORPL125A070
				90	ORPL125A090
				100	ORPL125A100
				110	ORPL125A125
				125	ORPL125A125
250	CHLD3250T52W	CHLD3250T56W	CHLD3250T57W	125	ORPL025A125
				150	ORPL025A150
				175	ORPL025A175
				200	ORPL025A200
				225	ORPL025A225
400	CHLD3400T52W	CHLD3400T56W	CHLD3400T57W	250	ORPL025A250
				200	ORPL40A200
				225	ORPL40A225
				250	ORPL40A250
				350	ORPL40A350
600	CHLD3600T52W	CHLD3600T56W	CHLD3600T57W	400	ORPL40A400
				300	ORPL60A300
				350	ORPL60A350
				400	ORPL60A400
				500	ORPL60A500
				600	ORPL60A600

**Notes**

- ① Long delay I<sup>4</sup>t response selection limits short delay time to flat response.
- ② Zone interlocking, PowerNet, or both features can be added at the factory by adding suffixes **ZG**, **PN** or **ZGP** respectively to above catalog number.

## 100% Rated Digitrip OPTIM 550 Circuit Breakers with Interchangeable Rating Plug, continued

Maximum Continuous Ampere Rating at 40 °C	Circuit Breaker Frame Only			Digitrip OPTIM Rating Plug Only	
	LSI Catalog Number	LSIG Catalog Number	LSIA Catalog Number	Ampere Rating	Fixed Rating Plug Catalog Number
	L – Adjustable Long Delay Pickup (I <sub>1</sub> ) with Adjustable Long Delay Time (I <sup>2</sup> t or I <sup>4</sup> t Response) ① S – Adjustable Short Delay Pickup with Adjustable Short Delay Time (I <sup>2</sup> t or Flat Response) I – Adjustable Instantaneous Pickup G – Adjustable Ground Fault Pickup with Adjustable Ground Fault Time (I <sup>2</sup> t or Flat Response) A – Adjustable Ground Fault Alarm with Adjustable Ground Fault Time (I <sup>2</sup> t or Flat Response) OPTIM 550 ②				
<b>Three-Pole Ultra High Interrupting Capacity Current Limiting 600 Vac Rated 100 kAIC at 480 Vac</b>					
125	CLDC3125T52W	CLDC3125T56W	CLDC3125T57W	70	ORPL125A070
				90	ORPL125A090
				100	ORPL125A100
				110	ORPL125A110
				125	ORPL125A125
250	CLDC3250T52W	CLDC3250T56W	CLDC3250T57W	125	ORPL025A125
				150	ORPL025A150
				175	ORPL025A175
				200	ORPL025A200
				225	ORPL025A225
400	CLDC3400T52W	CLDC3400T56W	CLDC3400T57W	200	ORPL40A200
				225	ORPL40A225
				250	ORPL40A250
				300	ORPL40A300
				350	ORPL40A350
600	CLDC3600T52W	CLDC3600T56W	CLDC3600T57W	400	ORPL60A400
				500	ORPL60A500
				600	ORPL60A600

**Notes**

① Long delay I<sup>4</sup>t response selection limits short delay time to flat response.

② Zone interlocking, PowerNet, or both features can be added at the factory by adding suffixes **ZG**, **PN** or **ZGP** respectively to above catalog number.

#### 100% Rated Digitrip OPTIM 1050 Circuit Breakers with Interchangeable Rating Plug

**Circuit Breaker Frame Only**

- L – Adjustable Long Delay Pickup (I<sub>1</sub>) with Adjustable Long Delay Time (I<sup>2</sup>t or I<sup>4</sup>t Response) ①
- S – Adjustable Short Delay Pickup with Adjustable Short Delay Time (I<sup>2</sup>t or Flat Response)
- I – Adjustable Instantaneous Pickup
- G – Adjustable Ground Fault Pickup with Adjustable Ground Fault Time (I<sup>2</sup>t or Flat Response)
- A – Adjustable Ground Fault Alarm with Adjustable Ground Fault Time (I<sup>2</sup>t or Flat Response)

**OPTIM 1050 ②③**

**Digitrip OPTIM Rating Plug Only**

Maximum  
Continuous  
Ampere  
Rating  
at 40 °C

LSIG

Catalog  
Number

LSIA

Catalog  
Number

Ampere  
Rating

Fixed Rating Plug

Catalog  
Number

Three-Pole Standard Interrupting Capacity 600 Vac Rated 35 kAIC at 480 Vac				
Maximum Continuous Ampere Rating at 40 °C	LSIG Catalog Number	LSIA Catalog Number	Ampere Rating	Fixed Rating Plug Catalog Number
125	CLD3125T106W	CLD3125T107W	70	ORPL125A070
			90	ORPL125A090
			100	ORPL125A100
			110	ORPL125A110
			125	ORPL125A125
250	CLD3250T106W	CLD3250T107W	125	ORPL025A125
			150	ORPL025A150
			175	ORPL025A175
			200	ORPL025A200
			225	ORPL025A225
			250	ORPL025A250
400	CLD3400T106W	CLD3400T107W	200	ORPL40A200
			225	ORPL40A225
			250	ORPL40A250
			300	ORPL40A300
			350	ORPL40A350
			400	ORPL40A400
			600	ORPL60A600
600	CLD3600T106W	CLD3600T107W	300	ORPL60A300
			350	ORPL60A350
			400	ORPL60A400
			500	ORPL60A500
			600	ORPL60A600

**Notes**

- ① Long delay I<sup>4</sup>t response selection limits short delay time to flat response.
- ② One Form C auxiliary switch and one Form C bell alarm switch supplied with breaker as standard.
- ③ Factory sealed.

## 100% Rated Digitrip OPTIM 1050 Circuit Breakers with Interchangeable Rating Plug, continued

Maximum Continuous Ampere Rating at 40 °C	Circuit Breaker Frame Only		Digitrip OPTIM Rating Plug Only	
	LSIG Catalog Number	LSIA Catalog Number	Ampere Rating	Fixed Rating Plug Catalog Number
	OPTIM 1050 <sup>②③</sup>			
	L – Adjustable Long Delay Pickup ( $I_L$ ) with Adjustable Long Delay Time ( $I^2t$ or $I^4t$ Response) <sup>①</sup>			
	S – Adjustable Short Delay Pickup with Adjustable Short Delay Time ( $I^2t$ or Flat Response)			
	I – Adjustable Instantaneous Pickup			
	G – Adjustable Ground Fault Pickup with Adjustable Ground Fault Time ( $I^2t$ or Flat Response)			
	A – Adjustable Ground Fault Alarm with Adjustable Ground Fault Time ( $I^2t$ or Flat Response)			
<b>Three-Pole High Interrupting Capacity 600 Vac Rated 65 kAIC at 480 Vac</b>				
125	CHLD3125T106W	CHLD3125T107W	70	ORPL125A070
			90	ORPL125A090
			100	ORPL125A100
			110	ORPL125A110
			125	ORPL125A125
250	CHLD3250T106W	CHLD3250T107W	125	ORPL025A125
			150	ORPL025A150
			175	ORPL025A175
			200	ORPL025A200
			225	ORPL025A225
400	CHLD3400T106W	CHLD3400T107W	250	ORPL025A250
			200	ORPL40A200
			225	ORPL40A225
			250	ORPL40A250
			300	ORPL40A300
600	CHLD3600T106W	CHLD3600T107W	350	ORPL40A350
			400	ORPL40A400
			300	ORPL60A300
			350	ORPL60A350
			400	ORPL60A400
600	CHLD3600T106W	CHLD3600T107W	500	ORPL60A500
			600	ORPL60A600

**Notes**

- ① Long delay  $I^4t$  response selection limits short delay time to flat response.  
 ② One Form C auxiliary switch and one Form C bell alarm switch supplied with breaker as standard.  
 ③ Factory sealed.

#### 100% Rated Digitrip OPTIM 1050 Electronic Circuit Breaker with Interchangeable Rating Plug, continued

Maximum Continuous Ampere Rating at 40 °C	Circuit Breaker Frame Only		Digitrip OPTIM Rating Plug Only	
	LSIG Catalog Number	LSIA Catalog Number	Ampere Rating	Fixed Rating Plug Catalog Number
	<b>OPTIM 1050</b> ②③			
	<b>L</b> – Adjustable Long Delay Pickup ( $I_L$ ) with Adjustable Long Delay Time ( $I^2t$ or $I^4t$ Response) ①			
	<b>S</b> – Adjustable Short Delay Pickup with Adjustable Short Delay Time ( $I^2t$ or Flat Response)			
	<b>I</b> – Adjustable Instantaneous Pickup			
	<b>G</b> – Adjustable Ground Fault Pickup with Adjustable Ground Fault Time ( $I^2t$ or Flat Response)			
	<b>A</b> – Adjustable Ground Fault Alarm with Adjustable Ground Fault Time ( $I^2t$ or Flat Response)			
<b>Three-Pole Ultra High Interrupting Capacity Current Limiting 600 Vac Rated 100 kAIC at 480 Vac</b>				
125	CLDC3125T106W	CLDC3125T107W	70	ORPL125A070
			90	ORPL125A090
			100	ORPL125A100
			110	ORPL125A110
			125	ORPL125A125
250	CLDC3250T106W	CLDC3250T107W	125	ORPL025A125
			150	ORPL025A150
			175	ORPL025A175
			200	ORPL025A200
			225	ORPL025A225
400	CLDC3400T106W	CLDC3400T107W	250	ORPL025A250
			200	ORPL40A200
			225	ORPL40A225
			250	ORPL40A250
			300	ORPL40A300
600	CLDC3600T106W	CLDC3600T107W	350	ORPL40A350
			400	ORPL40A400
			300	ORPL60A300
			350	ORPL60A350
			400	ORPL60A400
			500	ORPL60A500
			600	ORPL60A600

**Notes**

- ① Long delay  $I^4t$  response selection limits short delay time to flat response.
- ② One Form C auxiliary switch and one Form C bell alarm switch supplied with breaker as standard.
- ③ Factory sealed.

**Accessories Selection Guide and Ordering Information**

**Line and Load Terminals**

Eaton’s line and load terminals provide wire connecting capabilities for specific ranges of continuous current ratings and wire types. All terminals comply with Underwriters Laboratories Standards UL 486A and UL 486B and CSA Standard C22.2 No. 65M. Unless otherwise specified,

L-Frame circuit breaker line and load terminals are shipped separately for field installation.

The wire connecting terminal is secured with two pan-head, slotted screws and lockwashers that can be checked for the correct torque loading or retightened from the front of the circuit

breaker before installation of the conductors. (Applies to all styles.) The circuit breaker line/load terminal conductors are positioned in the conducting holes in the wire connecting terminal and are secured with recessed socket screws that are tightened to the correct torque loading from the front of the circuit breaker.

**Ordering Information**

L-Frame circuit breakers use Cu/Al terminals as standard. When optional copper terminals are required, order by catalog Number. Specify if factory installation is required.

**Terminals**

TA401LD or TA603LD Terminal (Step-Type Terminal Requires Terminal Cover and Warning Label. See Inset.)

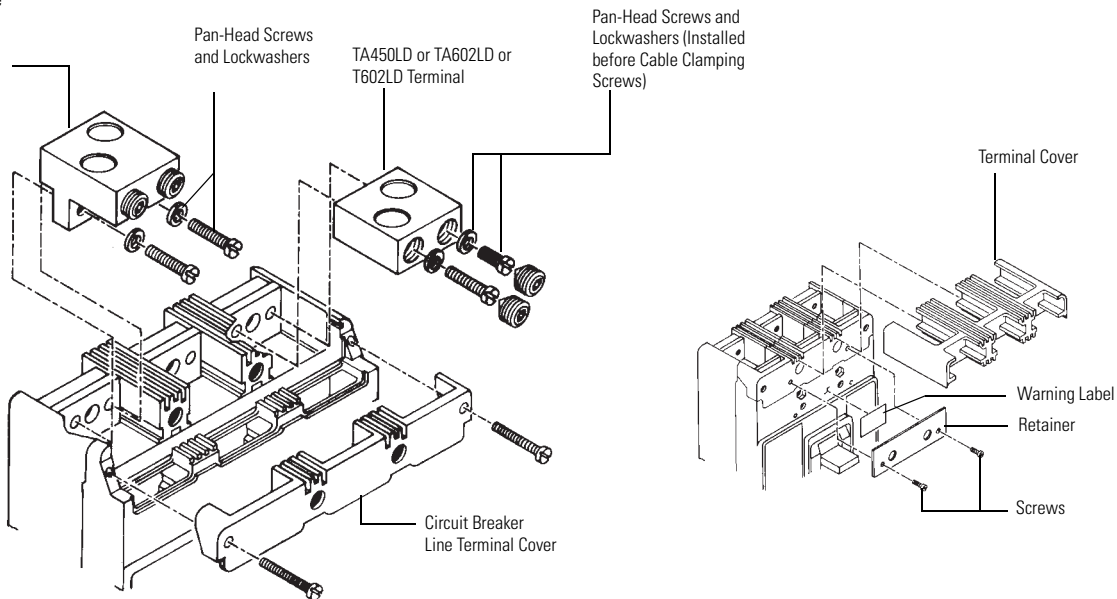

**Line and Load Terminals**

Maximum Breaker Amperes	Terminal Body Material	Wire Type	AWG Wire Range/Number of Conductors	Metric Wire Range mm <sup>2</sup>	Terminal Poles	Catalog Number	Terminals with Control Wire Termination Catalog Number
<b>Standard Cu/Al Pressure Terminals</b>							
400	Aluminum	Cu/Al	4/0–600 (1)	120–300	Two-pole kit ①	<b>2TA401LDK</b>	—
400	Aluminum	Cu/Al	4/0–600 (1)	120–300	Three-pole kit ①	<b>3TA401LDK</b>	—
400	Aluminum	Cu/Al	4/0–600 (1)	120–300	Four-pole kit ①	<b>4TA401LDK</b>	—
450	Aluminum	Cu/Al	4–4/0 (2)	25–95	②	<b>TA450LD</b>	—
500	Aluminum	Cu/Al	3/0–350 (2)	95–150	②	<b>TA602LD</b>	<b>TA602LDCW</b>
600	Aluminum	Cu/Al	400–500 (2)	185–240	Two-pole kit ①	<b>2TA603LDK</b>	<b>2TA603LDKCW</b>
600	Aluminum	Cu/Al	400–500 (2)	185–240	Three-pole kit ①	<b>3TA603LDK</b>	<b>3TA603LDKCW</b>
600	Aluminum	Cu/Al	400–500 (2)	185–240	Four-pole kit ①	<b>4TA603LDK</b>	<b>4TA603LDKCW</b>
<b>Optional Copper and Cu/Al Pressure Type Terminals</b>							
600	Copper	Cu	250–350 (2)	120–250	②	<b>T602LD</b>	<b>T602LDCW</b>

**Notes**

- ① Terminal kits contain one terminal for each pole and one terminal cover.
- ② Individually packed.

### Accessories

#### Allowable Accessory Combinations

Different combinations of accessories can be supplied, depending on the types of accessories and the number of poles in the circuit breaker.

#### LD Frame Accessories

Description	Reference Page	Two-Pole <sup>①</sup> , Three-Pole			Four-Pole			Neutral <sup>②</sup>
		Left	Center	Right	Left	Center	Right	
<b>Internal Accessories (Only One Internal Accessory Per Pole) <sup>③</sup></b>								
Alarm lockout (Make/Break)	V4-T2-276	■		■	■			■
Alarm lockout (2Make/2Break)	V4-T2-276	■		■	■			■
Auxiliary switch (1A, 1B)	V4-T2-278	■		■	■			■
Auxiliary switch (2A, 2B)	V4-T2-278	■		■	■			■
Auxiliary switch (3A, 3B)	V4-T2-278	■		■	■			■
Auxiliary switch (1A, 1B) and alarm switch combination	V4-T2-280	■		■	■			■
Auxiliary switch (2A, 2B) and alarm switch combination	V4-T2-280	■		■	■			■
Shunt trip—standard <sup>④</sup>	V4-T2-282	■		■	■			■
Shunt trip—low energy <sup>④</sup>	V4-T2-285	■		■	■			■
Undervoltage release mechanism <sup>④</sup>	V4-T2-291	■		■	■			■
Eaton PowerNet communications kit (OPTIM 550)	V4-T2-293			■				
<b>External Accessories</b>								
End cap kit	V4-T2-308	●	●	●	●	●	●	●
Control wire terminal kit	V4-T2-309	●	●	●	●	●	●	●
Base mounting hardware	V4-T2-311	●	●	●	●	●	●	●
Terminal shields	V4-T2-313	●	●	●	●	●	●	●
Interphase barriers	V4-T2-313	●	●	●	●	●	●	●
Non-padlockable handle block	V4-T2-314		■			■		
Padlockable handle lock hasp	V4-T2-315	□		□	□		□	
Key interlock kit	V4-T2-316	□		□	□		□	
Sliding bar interlock—requires two breakers	V4-T2-317	●	●	●				
Walking beam interlock—requires two breakers	V4-T2-317	●	●	●	●	●	●	●
Electrical (motor) operator	V4-T2-318	●	●	●	●	●	●	●
Plug-in adapters	V4-T2-320	●	●	●	●	●	●	●
Rear connecting studs	V4-T2-321	●	●	●	●	●	●	●
Panelboard connecting straps	V4-T2-322	●	●	●	●	●	●	●
Handle mechanisms	V4-T2-432	●	●	●	●	●	●	●
Handle extension	V4-T2-447	●	●	●	●	●	●	●
Solid-state (electronic) portable test kit	V4-T2-324	●	●	●	●	●	●	●

#### Legend

- Applicable in indicated pole position
- May be mounted on left or right pole—not both
- Accessory available/modification available

#### Notes

- ① Two-pole breaker supplied in three-pole frame. Current carrying parts omitted from center pole.
- ② Refer to Eaton for appropriate neutral pole accessory combinations.
- ③ OPTIM model 1050 is factory sealed and does not have the right pole space available for accessories.
- ④ Shunt trip and UVR cannot be mounted in right poles on LES or OPTIM trip units. Standard non-tripping internal accessories can be mounted in the left or right poles of LES and 550 OPTIM trip units.

## LD Frame Accessories, continued

Description	Reference Page	Two-Pole <sup>①</sup> , Three-Pole			Four-Pole			Neutral <sup>②</sup>
		Left	Center	Right	Left	Center	Right	
<b>OPTIM System Components Three Poles</b>								
Ground fault alarm unit	V4-T2-324							
Potential transformer module	V4-T2-324							
Breaker interface module (BIM)	V4-T2-325							
Digitrip OPTIMizer	V4-T2-325							
Auxiliary power module	V4-T2-325							
<b>Modifications (Refer to Eaton)</b>								
Special calibration	—	●	●	●	●	●	●	●
Moisture fungus treatment	V4-T2-116	●	●	●	●	●	●	●
Freeze-tested circuit breakers	—	●	●	●	●	●	●	●
Marine/naval application	—	●	●	●	●	●	●	●

**Legend**

- Applicable in indicated pole position
- May be mounted on left or right pole—not both
- Accessory available/modification available

## 310+ Electronic Trip Unit Accessories

Description	Catalog Number
Electronic portable test kit	MTST230V <sup>③</sup>
Trip unit tamper protection wire seal	5108A03H01
External neutral sensor	LGFACT600 <sup>④</sup>
Breaker-mount cause-of-trip indication	TRIP-LED
Breaker-mount ammeter module	DIGIVIEW
Remote-mount ammeter module	DIGIVIEWR06 <sup>⑤</sup>

**Notes**

- ① Two-pole breaker supplied in three-pole frame. Current carrying parts omitted from center pole.
- ② Refer to Eaton for appropriate neutral pole accessory combinations.
- ③ MTST230V applies to 100–230 Vac.
- ④ Included with all LD LSG and LSG trip units and breakers.
- ⑤ Includes 6 ft cable for remote mounting; NEMA 3R rated.

## Technical Data and Specifications

2

### UL 489 Interrupting Capacity Ratings <sup>①</sup>

Circuit Breaker Type	Number of Poles	Interrupting Capacity (kA rms Symmetrical Amperes)					
		Volts AC (50/60 Hz)				Volts DC	
		240	277	480	600	125	250 <sup>②③</sup>
LDB	2, 3	65	—	35	25	—	22
LD	2, 3, 4	65	—	35	25	—	22
CLD <sup>④</sup>	2, 3, 4	65	—	35	25	—	—
HLD, HLDB	2, 3, 4	100	—	65	35	—	25
CHLD <sup>④</sup>	2, 3, 4	100	—	65	35	—	—
LDC, LDCB <sup>⑤</sup>	2, 3, 4	200	—	100	50	—	30
CLDC <sup>④⑤</sup>	2, 3, 4	200	—	100	50	—	—

### IEC 947-2 Interrupting Capacity Ratings <sup>①</sup>

Circuit Breaker Type	Number of Poles	Interrupting Capacity (kA Symmetrical Amperes)							
		Volts AC (50/60 Hz)				Volts DC			
		240		415		690		250 <sup>②③</sup>	
		$I_{cu}$	$I_{cs}$	$I_{cu}$	$I_{cs}$	$I_{cu}$	$I_{cs}$	$I_{cu}$	$I_{cs}$
LDB	2, 3	85	85	45	45	20	10	20	10
LD	2, 3, 4	85	85	45	45	20	10	20	10
CLD <sup>④</sup>	2, 3, 4	85	85	45	45	20	10	—	—
HLD, HLDB	2, 3, 4	100	100	70	70	25	13	20	10
CHLD <sup>④</sup>	2, 3, 4	100	100	70	70	25	13	—	—
LDC, LDCB	2, 3, 4	200	100	100	75	35	18	20	10
CLDC <sup>④</sup>	2, 3, 4	200	100	100	75	35	18	—	—

### UL 489 Current Limiting Data

Frame	Circuit	$I_p$ (kA)	$I^2T$ ( $10^6 A^2S$ )
LDC	240 V/200 kA	64.80	6.80
LDC	480 V/100 kA	66.90	9.33
LDC	600 V/50 kA	54.30	8.92

#### Notes

- ① Utilization Category A circuit breakers.
- ② L/R = 8 milliseconds minimum.
- ③ Two-pole circuit breaker or two poles of three-pole circuit breaker. Incorporating thermal-magnetic trip unit only.
- ④ 100% rated breakers.
- ⑤ Current limiting.

## 310+ Specifications

Description	Specification
Trip Unit Type	Digitrip RMS 310+
<b>Breaker Type</b>	
Frame designation	LD
Frames available	600 A
Continuous current range (A)	250–600 A
Ground fault pickup (A)	120–600 A
Interrupting capacities at 480 Vac (kAIC)	35, 65, 100
100% rated	Yes
<b>Protection</b>	
Ordering options	LS, LSI, LSG, LSIG, ALSI, ALSIG
Arcflash Reduction Maintenance System (or Maintenance Mode)	Remote enabled on ALSI, ALSIG
Interchangeable trip unit	Yes
High load alarm (suffix B20) ①	Yes
Ground fault alarm with trip (suffix B21) ①	LSG, LSIG, ALSIG
Ground fault alarm, no trip (suffix B22) ①	LSG, LSIG, ALSIG
Zone selective interlocking (suffix ZG)	LSI, LSIG, ALSI, ALSIG
Cause of trip indication	Yes (via TRIP-LED or DIGIVIEW)
Thru-cover accessories	No

## 310+ Adjustability Specifications

Description	LD Frame Specification	
310+ settings	600 A	
$I_r$ = continuous current or long delay pickup (amperes) (All 310+)	$I_r$	
	A	250
	B	300
	C	315
	D	350
	E	400
	F	450
	G	500
	H (= $I_n$ )	600
$t_r$ = long delay time (seconds) (All 310+)		
	2	2
	4	4
	7	7
	10	10
	12	12
	15	15
	20	20
	24	24
$I_{sd}$ (x $I_r$ ) = short delay pickup (All 310+)		
	Position 1	2x
	Position 2	3x
	Position 3	4x
	Position 4	5x
	Position 5	6x
	Position 6	7x
	Position 7	8x
	Position 8	8x
	Position 9	8x
$t_{sd}$ = short delay time $I^2t$ (milliseconds) (LS and LSG)	Fixed	67 @10x
$t_{sd}$ = short delay time flat (milliseconds) (LSI, LSIG, ALSI, ALSIG)		
	Position 1	Inst
	Position 2	120
	Position 3	300
$I_g$ (x $I_n$ ) = ground fault pickup (amperes) (LSG, LSIG, ALSIG)		
	Position 1	120
	Position 2	180
	Position 3	240
	Position 4	360
	Position 5	480
	Position 6	600
$t_g$ = ground fault delay time (milliseconds) (LSG, LSIG, ALSIG)		
	Position 1	Inst
	Position 2	120
	Position 3	300
Independently adjustable Instantaneous (Ii) setting	②	
Maintenance Mode pickup (2.5 x $I_n$ ) (amperes) (310+ with Maintenance Mode—ALSI and ALSIG)	Fixed	1500

**Notes**

- ① B2x suffixes cannot be combined with B2x suffixes.  
 ② Not available for LD. Independently adjustable Ii setting available in LG, NG, and RG ALSI and ALSIG trip units.

## Digitrip OPTIM Specifications

Trip Unit Type	Digitrip OPTIM 550	Digitrip OPTIM 1050
rms sensing	Yes	Yes
<b>Breaker Type</b>		
Frame	L	L
Ampere range	200–600 A	200–600 A
Interrupting rating at 480 volts	35, 65, 100 (kA)	35, 65, 100 (kA)
<b>Protection</b>		
Ordering options	LSI, LSI(A), LSIG	LSI(A), LSIG
Fixed rated plug ( $I_n$ )	Yes	Yes
Overtemperature trip	Yes	Yes
<b>Long Delay Protection (L)</b>		
Adjustable rating plug ( $I_n$ )	No	No
Long delay pickup	0.4–1.0 x ( $I_n$ )	0.4–1.0 x ( $I_n$ )
Long delay time $I^2t$	2–24 seconds	2–24 seconds
Long delay time $I^4t$	1–5 seconds	1–5 seconds
Long delay thermal memory	Yes	Yes
High load alarm	0.5–1.0 x $I_r$	0.5–1.0 x $I_r$
<b>Short Delay Protection (S)</b>		
Short delay pickup	150–800% x ( $I_r$ )	150–800% x ( $I_r$ )
Short delay time $I^2t$	100–500 ms	100–500 ms
Short delay time flat	100–500 ms	100–500 ms
Short delay time zone selective interlocking	Yes <sup>①</sup>	Yes
<b>Instantaneous Protection (I)</b>		
Instantaneous pickup	200–800% x ( $I_n$ )	200–800% x ( $I_n$ )
Discriminator	Yes	Yes
Instantaneous override	Yes	Yes
<b>Ground Fault Protection (G)</b>		
Ground fault alarm	20–100% x ( $I_g$ )	20–100% x ( $I_g$ )
Ground fault pickup	20–100% x ( $I_g$ )	20–100% x ( $I_g$ )
Ground fault delay $I^2t$	100–500 ms	100–500 ms
Ground fault delay flat	100–500 ms	100–500 ms
Ground fault zone selective interlocking	Yes <sup>①</sup>	Yes
Ground fault thermal memory	Yes	Yes

**Legend**

BIM = Breaker Interface Module  
(A) = GF Alarm  
 $I_g$  = Sensor Rating  
 $I_n$  = Rating Plug  
 $I_r$  = Long Delay Pickup Setting

**Note**

① Zone interlock kit.

**Digitrip OPTIM Specifications, continued**

<b>Trip Unit Type</b>	<b>Digitrip OPTIM 550</b>	<b>Digitrip OPTIM 1050</b>
<b>System Diagnostics</b>		
Status LEDs	Yes	Yes
Cause of trip LEDs	Yes	Yes
Magnitude of trip information	Yes	Yes
Remote signal contact—ground alarm	Yes <sup>①</sup>	Yes
Local auxiliary and bell alarm contact	Optional	Included
<b>System Monitoring</b>		
Digital display	Yes <sup>②</sup>	Yes <sup>②</sup>
Current	Yes	Yes
Power and energy	No	Yes
Power quality—harmonics	No	Yes
Power factor	No	Yes
<b>Communications</b>		
PowerNet	Yes <sup>③</sup>	Yes
<b>Testing</b>		
Testing method	OPTIMizer, BIM, PowerNet	OPTIMizer, BIM, PowerNet

**Legend**

BIM = Breaker Interface Module  
 (A) = GF Alarm  
 $I_s$  = Sensor Rating  
 $I_n$  = Rating Plug  
 $I_r$  = Long Delay Pickup Setting

**Notes**

- ① Zone interlock kit.  
 ② By OPTIMizer/BIM.  
 ③ Eaton's PowerNet kit.

# 2.3

## Molded Case Circuit Breakers

### Series C

#### Dimensions and Weights

Dimensions in Inches (mm)

2

#### LD Frame

Number of Poles	Width	Height	Depth
2, 3	8.25 (209.6)	10.75 (273.1)	4.06 (103.1)
4	11.00 (279.4)	10.75 (273.1)	4.06 (103.1)

#### LD-Frame, Two- and Three-Pole

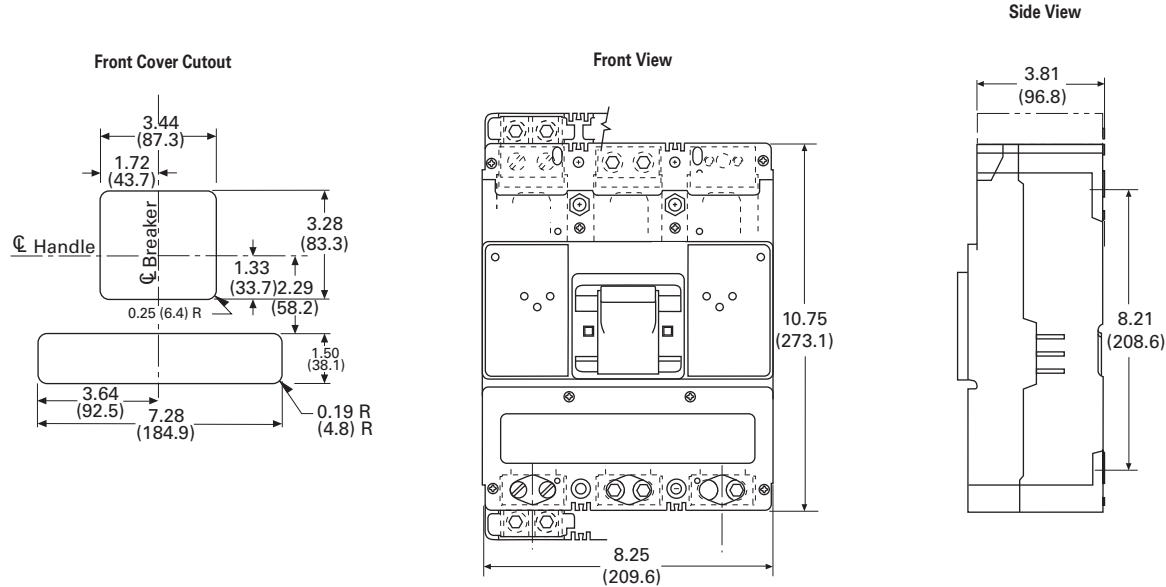

Approximate Shipping Weight, Lbs (kg)

#### LD Frame

Breaker Type	Complete Breaker			Frame Only			Trip Unit		
	Two-Pole	Three-Pole	Four-Pole	Two-Pole	Three-Pole	Four-Pole	Two-Pole	Three-Pole	Four-Pole
LD, HLD, LDC	18 (8.2)	20 (9.1)	25 (11.3)	14 (6.4)	15 (6.8)	20 (9.1)	3 (1.4)	4 (1.8)	5 (2.3)
LDB	18 (8.2)	20 (9.1)	25 (11.3)	—	—	—	—	—	—

Typical M-Frame Circuit Breaker



## Contents

<i>Description</i>	<i>Page</i>
Product Overview . . . . .	V4-T2-116
Standards and Certifications . . . . .	V4-T2-117
Quick Reference . . . . .	V4-T2-118
G-Frame (15–100 Amperes) . . . . .	V4-T2-121
F-Frame (10–225 Amperes) . . . . .	V4-T2-135
J-Frame (70–250 Amperes) . . . . .	V4-T2-153
K-Frame (70–400 Amperes) . . . . .	V4-T2-161
L-Frame (125–600 Amperes) . . . . .	V4-T2-185
M-Frame (300–800 Amperes)	
Catalog Number Selection . . . . .	V4-T2-212
Product Selection . . . . .	V4-T2-213
Accessories . . . . .	V4-T2-218
Technical Data and Specifications . . . . .	V4-T2-219
Dimensions and Weights . . . . .	V4-T2-221
Motor Circuit Protectors (MCP) . . . . .	V4-T2-256
N-Frame (400–1200 Amperes) . . . . .	V4-T2-222
R-Frame (800–2500 Amperes) . . . . .	V4-T2-237
Motor Protection Circuit Breakers (MPCB) . . . . .	V4-T2-267
Type ELC Current Limiter Attachment (Size 0–4) . . . . .	V4-T2-269
Current Limiting Circuit Breaker Module . . . . .	V4-T2-270
Internal Accessories . . . . .	V4-T2-273
External Accessories . . . . .	V4-T2-304

## M-Frame (300–800 Amperes)

### Product Description

- All Eaton M-Frame circuit breakers are HACR rated
- MDL-Frame circuit breakers are available as individual components (frame, trip unit, terminals), or factory assembled complete breakers
- MDLB, HMDLB-Frame circuit breakers with non-interchangeable trip units are suitable for reverse feed use

### Standards and Certifications

- CE marked



# 2.3

## Molded Case Circuit Breakers

### Series C

#### Catalog Number Selection

This information is presented only as an aid to understanding catalog numbers. It is not to be used to build catalog numbers for circuit breakers or trip units.

2

#### MDL Frame with Thermal-Magnetic Trip Unit Technology

##### Thermal-Magnetic Breakers and Frame ①

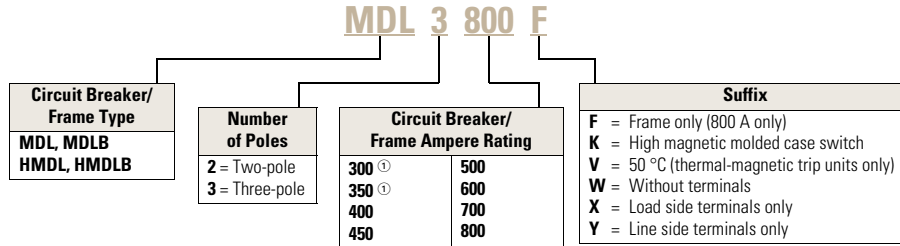

##### Thermal-Magnetic Trip Unit ①

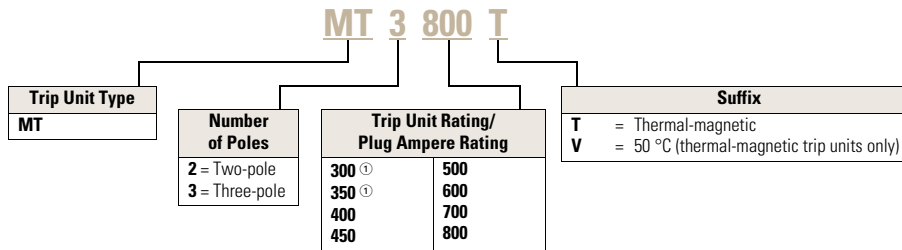

#### MDL Frame with 310+ Electronic Trip Unit Technology

##### 310+ Circuit Breaker

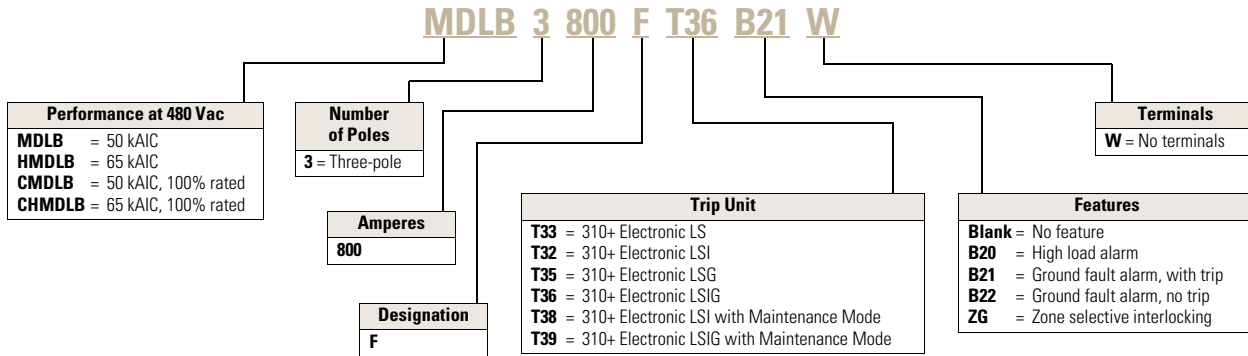

##### 310+ Electronic Trip Unit ①

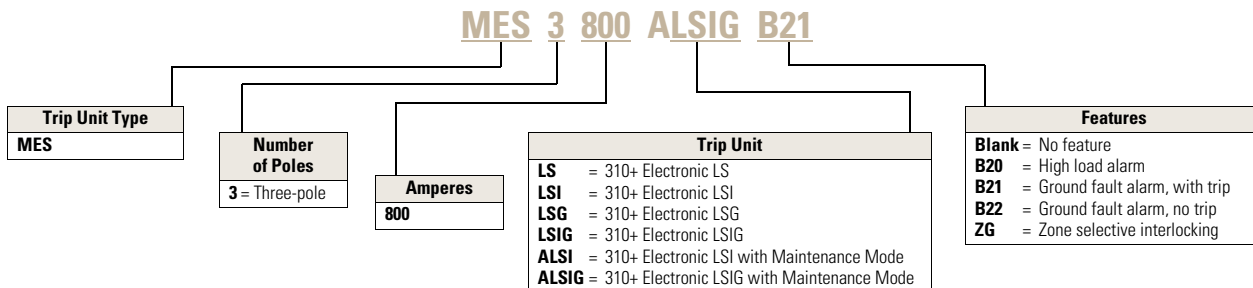

#### Note

① Frames are the same for thermal-magnetic or 310+ electronic trip units, e.g., MDL3800F, HMDL3800F, etc.

## Product Selection

## Types MDL and HMDL Thermal-Magnetic Circuit Breakers with Interchangeable Trip Units—Two-Pole

Maximum Continuous Ampere Rating at 40 °C	Standard Interrupting Capacity 600 Vac Rated 50 kAIC at 480 Vac		High Interrupting Capacity 600 Vac Rated 65 kAIC at 480 Vac		Thermal-Magnetic Trip Unit Only	Standard Terminals Only <sup>①</sup>  See Page V4-T2-217 for Optional Terminals Catalog Number
	Factory Assembled Circuit Consisting of Frame, Trip Unit and Terminals		Factory Assembled Circuit Consisting of Frame, Trip Unit and Terminals		For Use with Standard or High or Ultra High Interrupting Frames  Magnetic Trip Range is 5–10 Up Through 600 A; 4–8 on 700 and 800 A x Continuous Ampere Rating	
	Catalog Number	Frame Only Catalog Number	Catalog Number	Frame Only Catalog Number		
300	MDL2300	MDL2800F	HMDL2300	HMDL2800F	MT2300T	TA700MA1
350	MDL2350		HMDL2350		MT2350T	TA700MA1
400	MDL2400		HMDL2400		MT2400T	TA700MA1
450	MDL2450		HMDL2450		MT2450T	TA700MA1
500	MDL2500		HMDL2500		MT2500T	TA700MA1
600	MDL2600		HMDL2600		MT2600T	TA700MA1
700	MDL2700		HMDL2700		MT2700T	TA700MA1
800	MDL2800		HMDL2800		MT2800T	TA800MA2

## Types MDL and HMDL Thermal-Magnetic Circuit Breakers with Interchangeable Trip Units—Three-Pole

Maximum Continuous Ampere Rating at 40 °C	Standard Interrupting Capacity 600 Vac Rated 50 kAIC at 480 Vac		High Interrupting Capacity 600 Vac Rated 65 kAIC at 480 Vac		Thermal-Magnetic Trip Unit Only	Standard Terminals Only <sup>①</sup>  See Page V4-T2-217 for Optional Terminals Catalog Number
	Factory Assembled Circuit Consisting of Frame, Trip Unit and Terminals		Factory Assembled Circuit Consisting of Frame, Trip Unit and Terminals		For Use with Standard or High or Ultra High Interrupting Frames  Magnetic Trip Range is 5–10 Up Through 600 A; 4–8 on 700 and 800 A x Continuous Ampere Rating	
	Catalog Number	Frame Only Catalog Number	Catalog Number	Frame Only Catalog Number		
300	MDL3300	MDL3800F	HMDL3300	HMDL3800F	MT3300T	TA700MA1
350	MDL3350		HMDL3350		MT3400T	TA700MA1
400	MDL3400		HMDL3400		MT3400T	TA700MA1
450	MDL3450		HMDL3450		MT3450T	TA700MA1
500	MDL3500		HMDL3500		MT3500T	TA700MA1
600	MDL3600		HMDL3600		MT3600T	TA700MA1
700	MDL3700		HMDL3700		MT3700T	TA700MA1
800	MDL3800		HMDL3800		MT3800T	TA800MA2

**Note**

<sup>①</sup> Two terminals are required per pole.

## Types MDLB and HMDLB Thermal-Magnetic Circuit Breakers with Non-Interchangeable Trip Units—Two-Pole ①

Maximum Continuous Ampere Rating at 40 °C	Standard Interrupting Capacity	High Interrupting Capacity	Standard Terminals Only ②
	600 Vac Rated 50 kAIC at 480 Vac Factory Assembled Circuit Consisting of Frame, Trip Unit and Terminals Catalog Number	600 Vac Rated 65 kAIC at 480 Vac Factory Assembled Circuit Consisting of Frame, Trip Unit and Terminals Catalog Number	See Page V4-T2-217 for Optional Terminals Catalog Number
300	MDLB2300	HMDLB2300	TA700MA1
350	MDLB2350	HMDLB2350	TA700MA1
400	MDLB2400	HMDLB2400	TA700MA1
450	MDLB2450	HMDLB2450	TA700MA1
500	MDLB2500	HMDLB2500	TA700MA1
600	MDLB2600	HMDLB2600	TA700MA1
700	MDLB2700	HMDLB2700	TA700MA1
800	MDLB2800	HMDLB2800	TA800MA2

## Types MDLB and HMDLB Thermal-Magnetic Circuit Breakers with Non-Interchangeable Trip Units—Three-Pole ①

Maximum Continuous Ampere Rating at 40 °C	Standard Interrupting Capacity	High Interrupting Capacity	Standard Terminals Only ②
	600 Vac Rated 50 kAIC at 480 Vac Factory Assembled Circuit Consisting of Frame, Trip Unit and Terminals Catalog Number	600 Vac Rated 65 kAIC at 480 Vac Factory Assembled Circuit Consisting of Frame, Trip Unit and Terminals Catalog Number	See Page V4-T2-217 for Optional Terminals Catalog Number
300	MDLB3300	HMDLB3300	TA700MA1
350	MDLB3350	HMDLB3350	TA700MA1
400	MDLB3400	HMDLB3400	TA700MA1
450	MDLB3450	HMDLB3450	TA700MA1
500	MDLB3500	HMDLB3500	TA700MA1
600	MDLB3600	HMDLB3600	TA700MA1
700	MDLB3700	HMDLB3700	TA700MA1
800	MDLB3800	HMDLB3800	TA800MA2

**Notes**

① Factory sealed for reverse feed application.

② Two terminals are required per pole.

**Types MDL and HMDL Electronic Circuit Breakers with Interchangeable Trip Units**

Order as Individual Components: breaker frame, trip unit and terminals.  
See 310+ adjustability specifications on **Page V4-T2-220**.

**Types MDL and HMDL Electronic Circuit Breakers with Interchangeable 310+ Trip Units—Three-Pole**

Maximum Continuous Ampere Rating at 40 °C	Circuit Breaker Frame Only		Digitrip RMS 310+ Trip Unit Only ①				Neutral CT for LSG and LSIG ②③	Terminal Information
	Standard Interrupting Capacity 600 Vac Rated 50 kAIC at 480 Vac	High Interrupting Capacity 600 Vac Rated 65 kAIC at 480 Vac	Standard LS	Optional LSI	LSG	LSIG		
			Adjustable Short Time Pickup with I <sup>2</sup> t Short Delay Ramp	Independently Adjustable Short Time Pickup and Delay	Adjustable Short Time Pickup with I <sup>2</sup> t Short Delay and Ground Fault Protection	Independently Adjustable Short Time Pickup and Ground Fault Protection		
	Catalog Number	Catalog Number	Catalog Number				Catalog Number	
800	MDL3800F	HMDL3800F	MES3800LS	MES3800LSI	MES3800LSG	MES3800LSIG	LGFACT600	See Page V4-T2-218

**Types MDLB and HMDLB Electronic Circuit Breakers with Non-Interchangeable 310+ Trip Units ④**

Maximum Continuous Ampere Rating at 40 °C	Factory-Assembled Circuit Breaker Consisting of Frame and Trip Unit Less Terminals					Neutral CT for LSG and LSIG ②③
	LS	LSI	LSG	LSIG		
	Adjustable Short Time Pickup with I <sup>2</sup> t Short Delay Ramp	Independently Adjustable Short Time Pickup and Delay	Adjustable Short Time Pickup with I <sup>2</sup> t Short Delay and Ground Fault Protection	Independently Adjustable Short Time Pickup and Ground Fault Protection	Catalog Number	
	Three-Pole Standard Interrupting Capacity 600 Vac Rated 50 kAIC at 480 Vac					
800	MDLB3800FT33W	MDLB3800FT32W	MDLB3800FT35W	MDLB3800FT36W	MDLB3800FT36W	LGFACT600
	Three-Pole High Interrupting Capacity 600 Vac Rated 65 kAIC at 480 Vac					
800	HMDLB3800FT33W	HMDLB3800FT32W	HMDLB3800FT35W	HMDLB3800FT36W	HMDLB3800FT36W	LGFACT600

**100% Rated Types CMDL and CHMDL Electronic Circuit Breakers with Interchangeable Trip Units**

The NEC allows the breaker to be rated at 100% of its frame size in an assembly, provided that 90 °C wire is applied at the 75 °C ampacity. All 100% rated circuit breakers have electronic trip units. Order as individual components: breaker frame, trip unit and terminals. See 310+ adjustability specifications on **Page V4-T2-220**.

**100% Rated Types CMDL and CHMDL Electronic Circuit Breakers with Interchangeable 310+ Trip Units—Three-Pole**

Maximum Continuous Ampere Rating at 40 °C	Circuit Breaker Frame Only		Digitrip RMS 310+ Trip Unit Only ①				Neutral CT for LSG and LSIG ②③	Terminal Information
	Standard Interrupting Capacity 600 Vac Rated 50 kAIC at 480 Vac	High Interrupting Capacity 600 Vac Rated 65 kAIC at 480 Vac	Standard LS	Options LSI	LSG	LSIG		
			Adjustable Short Time Pickup with I <sup>2</sup> t Short Delay Ramp	Independently Adjustable Short Time Pickup and Delay	Adjustable Short Time Pickup with I <sup>2</sup> t Short Delay and Ground Fault Protection	Independently Adjustable Short Time Pickup and Ground Fault Protection		
	Catalog Number	Catalog Number					Catalog Number	
800	CMDL3800F	CHMDL3800F	MES3800LS	MES3800LSI	MES3800LSG	MES3800LSIG	LGFACT600	See Page V4-T2-218

**Notes**

- ① For AC use only.
- ② Required for four-wire systems if neutral protection is desired.
- ③ Included with LSG and LSIG trip units or breakers.
- ④ Factory sealed, suitable for reverse feed application. CMDLB and CHMDLB are also available.

**Molded Case Switches**

Eaton's molded case switches are used as compact switches in applications requiring high current switching capabilities. Molded case switches are constructed of circuit breaker

components and are of the high instantaneous automatic type. Molded case switches are listed in accordance with Underwriters Laboratories Standard UL 489.

**Molded Case Switches**

Maximum Continuous Ampere Rating at 40 °C	600 Vac Maximum, 250 Vdc Circuit Breaker Only without Line and Load Terminals Catalog Number
<b>Two-Pole</b>	
800	MDL2800WK
	MDLB2800WK <sup>①</sup>
	HMDL2800WK
<b>Three-Pole</b>	
800	MDL3800WK
	MDLB3800WK <sup>①</sup>
	HMDL3800WK

**Notes**

<sup>①</sup> MDLB and HMDLB are suitable for reverse feed applications.

Molded case switch may trip above 6000 amperes.

## Accessories Selection Guide and Ordering Information

### Line and Load Terminals

M-Frame circuit breakers use Cu/Al terminals as standard. When optional copper or Cu/Al terminals are required, order by catalog number. Specify if factory installation is required.

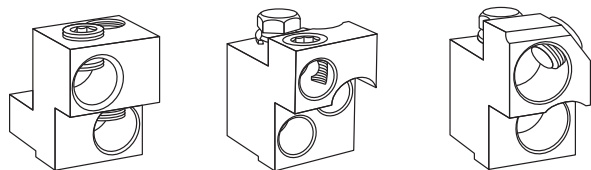

TA700MA1

TA800MA2

TA801MA

### Line and Load Terminals

Maximum Breaker Amperes	Terminal Body Material	Wire Type	AWG Wire Range/No. Conductors	Terminal Catalog Number	Terminals with Control Wire Termination Catalog Number
<b>Standard Cu/Al Pressure Terminals</b>					
700	Aluminum	Cu/Al	1–500 kcmil (2)	TA700MA1	TA700MA1CWT
800 std.	Aluminum	Cu/Al	3/0–400 kcmil (3)	TA800MA2	TA800MA2CWT
800	Aluminum	Cu/Al	500–750 kcmil (2)	TA801MA	TA801MACWT
<b>Optional Copper and Cu/Al Pressure Type Terminals</b>					
600	Copper	Cu	2/0–500 kcmil (2)	T600MA1	—
800	Copper	Cu	3/0–300 kcmil (3)	T800MA1	—

## Accessories

2

### Allowable Accessory Combinations

Different combinations of accessories can be supplied, depending on the types of accessories and the number of poles in the circuit breaker.

### MD Frame Accessories

Description	Reference Page	Two-Pole <sup>①</sup>		Three-Pole		
		Left	Right	Left	Center	Right
<b>Internal Accessories (Only One Internal Accessory Per Pole)</b>						
Alarm lockout (Make/Break)	V4-T2-276	■	■	■		■
Alarm lockout (2Make/2Break)	V4-T2-276	■	■	■		■
Auxiliary switch (1A, 1B)	V4-T2-278	■	■	■		■
Auxiliary switch (2A, 2B)	V4-T2-278	■	■	■		■
Auxiliary switch (3A, 3B)	V4-T2-278	■	■	■		■
Auxiliary switch (1A, 1B) and alarm switch combination	V4-T2-280	■	■	■		■
Auxiliary switch (2A, 2B) and alarm switch combination	V4-T2-280	■	■	■		■
Shunt trip—standard <sup>②</sup>	V4-T2-283	■	■	■		■
Shunt trip—low energy <sup>②</sup>	V4-T2-285	■	■	■		■
Undervoltage release mechanism <sup>②</sup>	V4-T2-291	■	■	■		■
<b>External Accessories</b>						
Rear fed terminals	V4-T2-310	●	●	●	●	●
Base mounting hardware	V4-T2-311				●	
Terminal shields	V4-T2-313				●	
Interphase barriers	V4-T2-313				●	
Non-padlockable handle block	V4-T2-314				■	
Padlockable handle lock hasp	V4-T2-315	□		□		□
Key interlock kit	V4-T2-316	□		□		□
Sliding bar interlock—requires two breakers	V4-T2-317	●	●	●	●	●
Walking beam interlock—requires two breakers	V4-T2-317	●	●	●	●	●
Electrical (motor) operator	V4-T2-318	●	●	●	●	●
Plug-in adapters	V4-T2-320	●	●	●	●	●
Rear connecting studs	V4-T2-321	●	●	●	●	●
Panelboard connecting straps	V4-T2-322	●	●	●	●	●
Handle mechanisms	V4-T2-432	●	●	●	●	●
Handle extension	V4-T2-447	●	●	●	●	●
Solid-state (electronic) portable test kit	V4-T2-324	●	●	●	●	●
<b>Modifications (Refer to Eaton)</b>						
Special calibration	—	●	●	●	●	●
Moisture fungus treatment	V4-T2-116	●	●	●	●	●
Freeze-tested circuit breakers	—	●	●	●	●	●
Marine/naval application	—	●	●	●	●	●

#### Legend

- Applicable in indicated pole position
- May be mounted on left or right pole—not both
- Accessory available/modification available

#### Notes

- ① Two-pole breaker supplied in three-pole frame. Current carrying parts omitted from center pole.  
 ② Shunt trip and UVR cannot be mounted in right poles on MES trip units.

**310+ Electronic Trip Unit Accessories**

Description	Catalog Number
Electronic portable test kit	MTST230V ①
Trip unit tamper protection wire seal	5108A03H01
External neutral sensor	LGFACT600 ②
Breaker-mount cause-of-trip indication	TRIP-LED
Breaker-mount ammeter module	DIGIVIEW
Remote-mount ammeter module	DIGIVIEWR06 ③

**Technical Data and Specifications****UL 489/CSA Interrupting Capacity Ratings ④**

Circuit Breaker Type	Number of Poles	Interrupting Capacity (kA Symmetrical Amperes)			Volts DC ⑤⑥
		Volts AC (50/60 Hz)			
		240	480	600	250
MDL, MDLB	2, 3	65	50	25	22
CMDL	2, 3	65	50	25	—
HMDL, HMDLB	2, 3	100	65	35	25
CHMDL	2, 3	100	65	35	—

**IEC 947-2 Interrupting Capacity Ratings ④**

Circuit Breaker Type	Number of Poles	Interrupting Capacity rms (kA Symmetrical Amperes) $I_{cu} \neq I_{cs}$			Volts DC ⑤⑥
		Volts AC (50/60 Hz)			
		240	415	690	250
MDL, MDLB	2, 3	65/65	50/50	20/10	20/10
CMDL	2, 3	65/65	50/50	20/10	—
HMDL, HMDLB	2, 3	100/100	70/50	25/13	20/10
CHMDL	2, 3	100/100	70/50	25/13	—

**Notes**

- ① MTST230V applies to 100–230 Vac.
- ② Included with all LD LSG and LSG trip units and breakers.
- ③ Includes 6 ft cable for remote mounting; NEMA 3R rated.
- ④ Utilization Category A circuit breakers.
- ⑤ Two-pole or two poles of three-pole circuit breaker. Thermal-magnetic trip units only, MDL, HMDL breakers with electronic trip unit are not DC rated.
- ⑥ Time constant is 3 milliseconds minimum at 10 kA and 8 milliseconds at 22 kA.

## 310+ Specifications

Description	Specification
Trip Unit Type	Digitrip RMS 310+
<b>Breaker Type</b>	
Frame designation	MDL
Frames available	800 A
Continuous current range (A)	320–800 A
Ground fault pickup (A)	160–800 A
Interrupting capacities at 480 Vac (kAIC)	50, 65
100% rated	Yes
<b>Protection</b>	
Ordering options	LS, LSI, LSG, LSIG, ALSI, ALSIG
Arcflash Reduction Maintenance System (or Maintenance Mode)	Remote enabled on ALSI, ALSIG
Interchangeable trip unit	Yes
High load alarm (suffix B20) ①	Yes
Ground fault alarm with trip (suffix B21) ①	LSG, LSIG, ALSIG
Ground fault alarm, no trip (suffix B22) ①	LSG, LSIG, ALSIG
Zone selective interlocking (suffix ZG)	LSI, LSIG, ALSI, ALSIG
Cause of trip indication	Yes (via TRIP-LED or DIGIVIEW)
Thru-cover accessories	No

## 310+ Adjustability Specifications

Description	MDL Frame Specification	
310+ settings	800 A	
$I_r$ = continuous current or long delay pickup (amperes) (All 310+)	$I_r$	
	A	320
	B	400
	C	450
	D	500
	E	600
	F	630
	G	700
	H (= $I_n$ )	800
$t_r$ = long delay time (seconds) (All 310+)	2	2
	4	4
	7	7
	10	10
	12	12
	15	15
	20	20
	24	24
$I_{sd}$ (x $I_r$ ) = short delay pickup (All 310+)	Position 1	2x
	Position 2	3x
	Position 3	4x
	Position 4	5x
	Position 5	6x
	Position 6	7x
	Position 7	8x
	Position 8	8x
	Position 9	8x
$t_{sd}$ = short delay time $I^2t$ (milliseconds) (LS and LSG)	Fixed	67 @10x
$t_{sd}$ = short delay time flat (milliseconds) (LSI, LSIG, ALSI, ALSIG)	Position 1	Inst
	Position 2	120
	Position 3	300
$I_g$ (x $I_n$ ) = ground fault pickup (amperes) (310+ w/ ground fault)	Position 1	160
	Position 2	240
	Position 3	320
	Position 4	480
	Position 5	640
	Position 6	800
$t_g$ = ground fault delay time (milliseconds) (LSG, LSIG, ALSIG)	Position 1	Inst
	Position 2	120
	Position 3	300
Independently adjustable Instantaneous (Ii) setting	②	
Maintenance Mode pickup (2.5 x $I_n$ ) (amperes) (310+ with Maintenance Mode—ALSI and ALSIG)	Fixed	2000

**Notes**

- ① B2x suffixes cannot be combined with B2x suffixes.  
 ② Not available for MDL. Independently adjustable Ii setting available in LG, NG, and RG ALSI and ALSIG trip units.

### Dimensions and Weights

Dimensions in Inches (mm)

#### MD Frame

Number of Poles	Width	Height	Depth
2, 3	8.25 (209.6)	16.00 (406.4)	4.06 (103.1)

#### MDL-Frame, Two- and Three-Pole

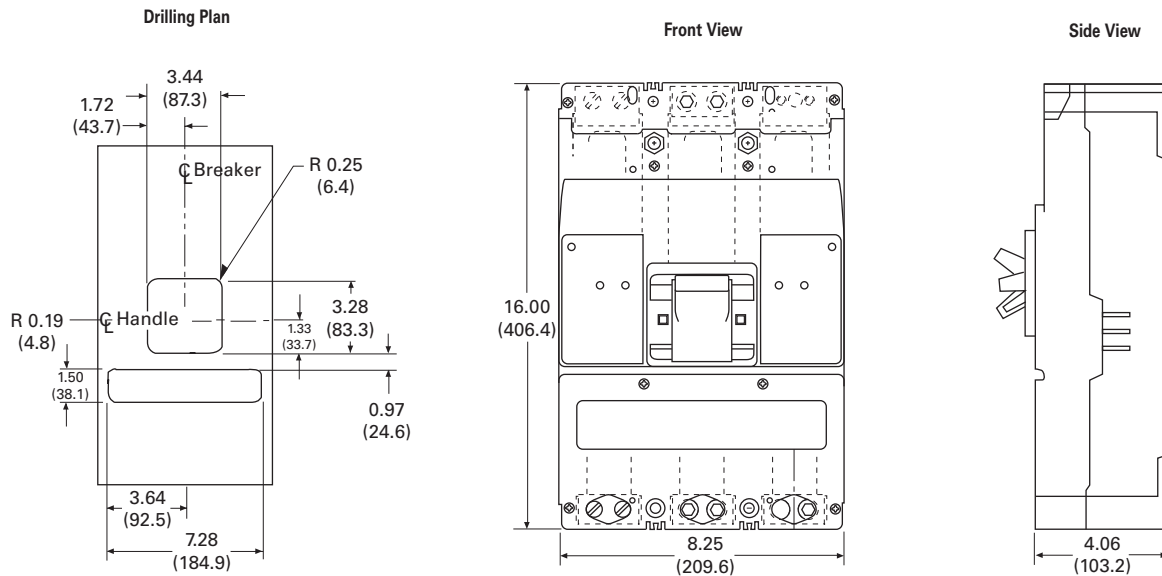

Approximate Shipping Weight, Lbs (kg)

#### MD Frame

Breaker Type	Complete Breaker		Frame Only		Trip Unit ①	
	Two-Pole	Three-Pole	Two-Pole	Three-Pole	Two-Pole	Three-Pole
MDL, HMDL (T/M T.U.)	26.5 (12.0)	29.0 (13.2)	24.5 (11.1)	26.0 (11.8)	2.5 (1.1)	3.0 (1.4)
MDL, HMDL (Elec. T.U.)	—	30.0 (13.6)	—	26.0 (11.8)	—	4.0 (1.8)

#### Note

① Thermal-magnetic only.

Typical N-Frame Breaker

2



### Contents

<i>Description</i>	<i>Page</i>
Product Overview . . . . .	<b>V4-T2-116</b>
Standards and Certifications . . . . .	<b>V4-T2-117</b>
Quick Reference . . . . .	<b>V4-T2-118</b>
G-Frame (15–100 Amperes) . . . . .	<b>V4-T2-121</b>
F-Frame (10–225 Amperes) . . . . .	<b>V4-T2-135</b>
J-Frame (70–250 Amperes) . . . . .	<b>V4-T2-153</b>
K-Frame (70–400 Amperes) . . . . .	<b>V4-T2-161</b>
L-Frame (125–600 Amperes) . . . . .	<b>V4-T2-185</b>
M-Frame (300–800 Amperes) . . . . .	<b>V4-T2-211</b>
N-Frame (400–1200 Amperes)	
Catalog Number Selection . . . . .	<b>V4-T2-223</b>
Product Selection . . . . .	<b>V4-T2-224</b>
Accessories . . . . .	<b>V4-T2-232</b>
Technical Data and Specifications . . . . .	<b>V4-T2-233</b>
Dimensions and Weights . . . . .	<b>V4-T2-236</b>
R-Frame (800–2500 Amperes) . . . . .	<b>V4-T2-237</b>
Motor Circuit Protectors (MCP) . . . . .	<b>V4-T2-256</b>
Motor Protection Circuit Breakers (MPCB) . . . . .	<b>V4-T2-267</b>
Type ELC Current Limiter Attachment (Size 0–4) . . . . .	<b>V4-T2-269</b>
Current Limiting Circuit Breaker Module . . . . .	<b>V4-T2-270</b>
Internal Accessories . . . . .	<b>V4-T2-273</b>
External Accessories . . . . .	<b>V4-T2-304</b>

### N-Frame (400–1200 Amperes)

#### Product Description

- All Eaton N-Frame circuit breakers are suitable for reverse feed use
- All N-Frame circuit breakers are HACR rated

**Catalog Number Selection**

This information is presented only as an aid to understanding catalog numbers. It is not to be used to build catalog numbers for circuit breakers or trip units.

**Circuit Breaker/Frame**

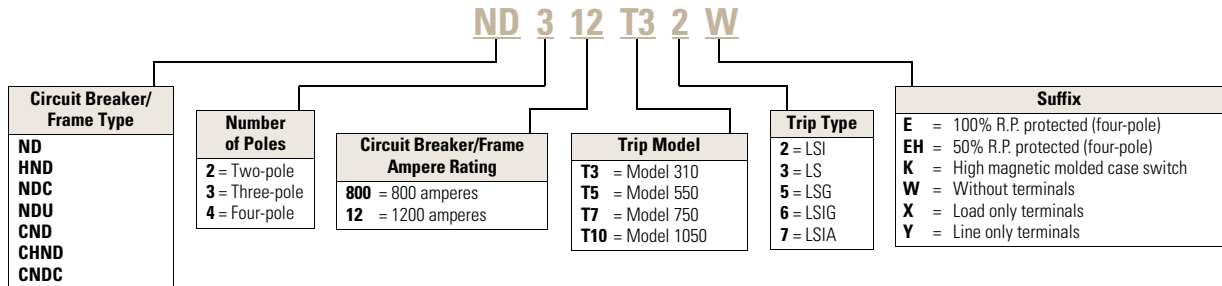

## Product Selection

2

**Digitrip OPTIM Electronic Circuit Breakers with Interchangeable Rating Plugs**

Order as individual components: breaker frame (which includes trip unit), rating plug, terminals.

**Digitrip OPTIM 550 Electronic Circuit Breakers with Interchangeable Rating Plugs**

Maximum Continuous Ampere Rating at 40 °C	Circuit Breaker Frame Only			Digitrip OPTIM Rating Plug Only	
	LSI Catalog Number	LSIG Catalog Number	LSIA Catalog Number	Ampere Rating	Fixed Rating Plug Catalog Number
	L – Adjustable Long Delay Pickup ( $I_t$ ) with Adjustable Long Delay Time ( $I^2t$ or $I^4t$ Response) <sup>①</sup> S – Adjustable Short Delay Pickup with Adjustable Short Delay Time ( $I^2t$ or Flat Response) I – Adjustable Instantaneous Pickup G – Adjustable Ground Fault Pickup with Adjustable Ground Fault Time Delay ( $I^2t$ or Flat Response) A – Adjustable Ground Fault Alarm with Adjustable Ground Fault Time Delay ( $I^2t$ or Flat Response) OPTIM 550 <sup>②</sup>				
<b>Three-Pole Standard Interrupting Capacity 600 Vac Rated 50 kAIC at 480 Vac</b>					
800	ND3800T52W	ND3800T56W	ND3800T57W	400	ORPN80A400
				450	ORPN80A450
				500	ORPN80A500
				550	ORPN80A550
				600	ORPN80A600
				700	ORPN80A700
1200	ND312T52W	ND312T56W	ND312T57W	800	ORPN80A800
				600	ORPN12A600
				700	ORPN12A700
				800	ORPN12A800
				1000	ORPN12A100
				1200	ORPN12A120
<b>Three-Pole High Interrupting Capacity 600 Vac Rated 65 kAIC at 480 Vac</b>					
800	HND3800T52W	HND3800T56W	HND3800T57W	400	ORPN80A400
				450	ORPN80A450
				500	ORPN80A500
				550	ORPN80A550
				600	ORPN80A600
				700	ORPN80A700
1200	HND312T52W	HND312T56W	HND312T57W	800	ORPN80A800
				600	ORPN12A600
				700	ORPN12A700
				800	ORPN12A800
				1000	ORPN12A100
				1200	ORPN12A120

**Notes**

<sup>①</sup> Long delay  $I^4t$  response selection limits short delay time to flat response.

<sup>②</sup> Zone interlocking, PowerNet, or both features can be added at the factory by adding suffixes **ZG**, **PN** or **ZGP** respectively to above catalog number.

## Digitrip OPTIM 550 Electronic Circuit Breakers with Interchangeable Rating Plugs, continued

Maximum Continuous Ampere Rating at 40 °C	Circuit Breaker Frame Only			Digitrip OPTIM Rating Plug Only	
	LSI Catalog Number	LSIG Catalog Number	LSIA Catalog Number	Ampere Rating	Fixed Rating Plug Catalog Number
	L – Adjustable Long Delay Pickup (I <sub>1</sub> ) with Adjustable Long Delay Time (I <sup>2</sup> t or I <sup>4</sup> t Response) ① S – Adjustable Short Delay Pickup with Adjustable Short Delay Time (I <sup>2</sup> t or Flat Response) I – Adjustable Instantaneous Pickup G – Adjustable Ground Fault Pickup with Adjustable Ground Fault Time Delay (I <sup>2</sup> t or Flat Response) A – Adjustable Ground Fault Alarm with Adjustable Ground Fault Time Delay (I <sup>2</sup> t or Flat Response) OPTIM 550 ②				
<b>Three-Pole Ultra High Interrupting Capacity 600 Vac Rated 100 kAIC at 480 Vac</b>					
800	NDC3800T52W	NDC3800T56W	NDC3800T57W	400	ORPN80A400
				450	ORPN80A450
				500	ORPN80A500
				550	ORPN80A550
				600	ORPN80A600
				700	ORPN80A700
				800	ORPN80A800
1200	NDC312T52W	NDC312T56W	NDC312T57W	600	ORPN12A600
				700	ORPN12A700
				800	ORPN12A800
				1000	ORPN12A100
				1200	ORPN12A120

**Notes**

- ① Long delay I<sup>4</sup>t response selection limits short delay time to flat response.  
 ② Zone interlocking, PowerNet, or both features can be added at the factory by adding suffixes **ZG**, **PN** or **ZGP** respectively to above catalog number.

#### Digitrip OPTIM 1050 Electronic Circuit Breakers with Interchangeable Rating Plugs

**Circuit Breaker Frame Only**

- L– Adjustable Long Delay Pickup ( $I_L$ ) with Adjustable Long Delay Time ( $I^2t$  or  $I^4t$  Response) ①
- S– Adjustable Short Delay Pickup with Adjustable Short Delay Time ( $I^2t$  or Flat Response)
- I– Adjustable Instantaneous Pickup
- G– Adjustable Ground Fault Pickup with Adjustable Ground Fault Time Delay ( $I^2t$  or Flat Response)
- A– Adjustable Ground Fault Alarm with Adjustable Ground Fault Time Delay ( $I^2t$  or Flat Response)

**Digitrip OPTIM Rating Plug Only**

Maximum Continuous Ampere Rating at 40 °C	LSIG Catalog Number	LSIA Catalog Number	Ampere Rating	Fixed Rating Plug Catalog Number
<b>Three-Pole Standard Interrupting Capacity 600 Vac Rated 50 kAIC at 480 Vac</b>				
800	ND3800T106W	ND3800T107W	400	ORPN80A400
			450	ORPN80A450
			500	ORPN80A500
			550	ORPN80A550
			600	ORPN80A600
			700	ORPN80A700
			800	ORPN80A800
1200	ND312T106W	ND312T107W	600	ORPN12A600
			700	ORPN12A700
			800	ORPN12A800
			1000	ORPN12A100
			1200	ORPN12A120
<b>Three-Pole High Interrupting Capacity 600 Vac Rated 65 kAIC at 480 Vac</b>				
800	HND3800T106W	HND3800T107W	400	ORPN80A400
			450	ORPN80A450
			500	ORPN80A500
			550	ORPN80A550
			600	ORPN80A600
			700	ORPN80A700
			800	ORPN80A800
1200	HND312T106W	HND312T107W	600	ORPN12A600
			700	ORPN12A700
			800	ORPN12A800
			1000	ORPN12A100
			1200	ORPN12A120
<b>Three-Pole Ultra High Interrupting Capacity 600 Vac Rated 100 kAIC at 480 Vac</b>				
800	NDC3800T106W	NDC3800T107W	400	ORPN80A400
			450	ORPN80A450
			500	ORPN80A500
			550	ORPN80A550
			600	ORPN80A600
			700	ORPN80A700
			800	ORPN80A800
1200	NDC312T106W	NDC312T107W	600	ORPN12A600
			700	ORPN12A700
			800	ORPN12A800
			1000	ORPN12A100
			1200	ORPN12A120

**Notes**

- ① Long delay  $I^4t$  response selection limits short delay time to flat response.
- ② One Form C auxiliary switch and one Form C bell (trip) alarm switch supplied with breaker as standard.
- ③ Factory sealed.

**100% Rated Digitrip OPTIM Circuit Breakers with Interchangeable Rating Plugs**

Order as individual components: breaker frame (which includes trip unit), rating plug, terminals.

**100% Rated Digitrip OPTIM 550 Circuit Breakers with Interchangeable Rating Plugs**

Maximum Continuous Ampere Rating at 40 °C	Circuit Breaker Frame Only			Digitrip OPTIM Rating Plug Only	
	LSI Catalog Number	LSIG Catalog Number	LSIA Catalog Number	Ampere Rating	Fixed Rating Plug Catalog Number
	L – Adjustable Long Delay Pickup ( $I_t$ ) with Adjustable Long Delay Time ( $I^2t$ or $I^4t$ Response) ① S – Adjustable Short Delay Pickup with Adjustable Short Delay Time ( $I^2t$ or Flat Response) I – Adjustable Instantaneous Pickup G – Adjustable Ground Fault Pickup with Adjustable Ground Fault Time Delay ( $I^2t$ or Flat Response) A – Adjustable Ground Fault Alarm with Adjustable Ground Fault Time Delay ( $I^2t$ or Flat Response) OPTIM 550 ②				
<b>Three-Pole Standard Interrupting Capacity 600 Vac Rated 50 kAIC at 480 Vac</b>					
800	CND3800T52W	CND3800T56W	CND3800T57W	400	ORPN80A400
				450	ORPN80A450
				500	ORPN80A500
				550	ORPN80A550
				600	ORPN80A600
				700	ORPN80A700
				800	ORPN80A800
1200 ③	CND312T52W	CND312T56W	CND312T57W	600	ORPN12A600
				700	ORPN12A700
				800	ORPN12A800
				1000	ORPN12A100
				1200	ORPN12A120
<b>Three-Pole High Interrupting Capacity 600 Vac Rated 65 kAIC at 480 Vac</b>					
800	CHND3800T52W	CHND3800T56W	CHND3800T57W	400	ORPN80A400
				450	ORPN80A450
				500	ORPN80A500
				550	ORPN80A550
				600	ORPN80A600
				700	ORPN80A700
				800	ORPN80A800
1200 ③	CHND312T52W	CHND312T56W	CHND312T57W	600	ORPN12A600
				700	ORPN12A700
				800	ORPN12A800
				1000	ORPN12A100
				1200	ORPN12A120

**Notes**

- ① Long delay  $I^4t$  response selection limits short delay time to flat response.  
 ② Zone interlocking, PowerNet, or both features can be added at the factory by adding suffixes **ZG**, **PN** or **ZGP** respectively to above catalog number.  
 ③ Includes conductor extension kit, which increases breaker length 3.75 on each end. Terminal ordered separate.

#### 100% Rated Digitrip OPTIM 550 Circuit Breakers with Interchangeable Rating Plugs, continued

Maximum Continuous Ampere Rating at 40 °C	Circuit Breaker Frame Only			Digitrip OPTIM Rating Plug Only	
	LSI Catalog Number	LSIG Catalog Number	LSIA Catalog Number	Ampere Rating	Fixed Rating Plug Catalog Number
	<b>OPTIM 550</b> <sup>②</sup> L – Adjustable Long Delay Pickup (I <sub>l</sub> ) with Adjustable Long Delay Time (I <sup>2</sup> t or I <sup>4</sup> t Response) <sup>①</sup> S – Adjustable Short Delay Pickup with Adjustable Short Delay Time (I <sup>2</sup> t or Flat Response) I – Adjustable Instantaneous Pickup G – Adjustable Ground Fault Pickup with Adjustable Ground Fault Time Delay (I <sup>2</sup> t or Flat Response) A – Adjustable Ground Fault Alarm with Adjustable Ground Fault Time Delay (I <sup>2</sup> t or Flat Response)				
<b>Three-Pole Ultra High Interrupting Capacity 600 Vac Rated 100 kAIC at 480 Vac</b>					
800	CNDC3800T52W	CNDC3800T56W	CNDC3800T57W	400	ORPN80A400
				450	ORPN80A450
				500	ORPN80A500
				550	ORPN80A550
				600	ORPN80A600
				700	ORPN80A700
				800	ORPN80A800
1200 <sup>③</sup>	CNDC312T52W	CNDC312T56W	CNDC312T57W	600	ORPN12A600
				700	ORPN12A700
				800	ORPN12A800
				1000	ORPN12A100
				1200	ORPN12A120

**Notes**

- ① Long delay I<sup>4</sup>t response selection limits short delay time to flat response.
- ② Zone interlocking, PowerNet, or both features can be added at the factory by adding suffixes **ZG**, **PN** or **ZGP** respectively to above catalog number.
- ③ Includes conductor extension kit, which increases breaker length 3.75 on each end. Terminal ordered separate.

## 100% Rated Digitrip OPTIM 1050 Circuit Breakers with Interchangeable Rating Plugs

Maximum Continuous Ampere Rating at 40 °C	Circuit Breaker Frame Only		Digitrip OPTIM Rating Plug Only	
	LSIG Catalog Number	LSIA Catalog Number	Ampere Rating	Fixed Rating Plug Catalog Number
<b>OPTIM 1050</b> ②③				
<b>L</b> – Adjustable Long Delay Pickup ( $I_L$ ) with Adjustable Long Delay Time ( $I^2t$ or $I^4t$ Response) ①				
<b>S</b> – Adjustable Short Delay Pickup with Adjustable Short Delay Time ( $I^2t$ or Flat Response)				
<b>I</b> – Adjustable Instantaneous Pickup				
<b>G</b> – Adjustable Ground Fault Pickup with Adjustable Ground Fault Time Delay ( $I^2t$ or Flat Response)				
<b>A</b> – Adjustable Ground Fault Alarm with Adjustable Ground Fault Time Delay ( $I^2t$ or Flat Response)				
<b>Three-Pole Standard Interrupting Capacity 600 Vac Rated 50 kAIC at 480 Vac</b>				
800	CND3800T106W	CND3800T107W	400	ORPN80A400
			450	ORPN80A450
			500	ORPN80A500
			550	ORPN80A550
			600	ORPN80A600
			700	ORPN80A700
			800	ORPN80A800
1200	CND312T106W	CND312T107W	600	ORPN12A600
			700	ORPN12A700
			800	ORPN12A800
			1000	ORPN12A100
			1200	ORPN12A120
<b>Three-Pole High Interrupting Capacity 600 Vac Rated 65 kAIC at 480 Vac</b>				
800	CHND3800T106W	CHND3800T107W	400	ORPN80A400
			450	ORPN80A450
			550	ORPN80A550
			600	ORPN80A600
			700	ORPN80A700
			800	ORPN80A800
1200	CHND312T106W	CHND312T107W	600	ORPN12A600
			700	ORPN12A700
			800	ORPN12A800
			1000	ORPN12A100
			1200	ORPN12A120

**Notes**

- ① Long delay  $I^4t$  response selection limits short delay time to flat response.  
 ② One Form C auxiliary switch one Form C bell (trip) alarm switch supplied with breaker as standard.  
 ③ Factory sealed.

#### 100% Rated Digitrip OPTIM 1050 Circuit Breakers with Interchangeable Rating Plugs, continued

Maximum Continuous Ampere Rating at 40 °C	Circuit Breaker Frame Only		Digitrip OPTIM Rating Plug Only	
	LSIG Catalog Number	LSIA Catalog Number	Ampere Rating	Fixed Rating Plug Catalog Number
	<b>OPTIM 1050</b> <sup>②③</sup> L – Adjustable Long Delay Pickup (I <sub>l</sub> ) with Adjustable Long Delay Time (I <sup>2</sup> t or I <sup>4</sup> t Response) <sup>①</sup> S – Adjustable Short Delay Pickup with Adjustable Short Delay Time (I <sup>2</sup> t or Flat Response) I – Adjustable Instantaneous Pickup G – Adjustable Ground Fault Pickup with Adjustable Ground Fault Time Delay (I <sup>2</sup> t or Flat Response) A – Adjustable Ground Fault Alarm with Adjustable Ground Fault Time Delay (I <sup>2</sup> t or Flat Response)			
<b>Three-Pole Ultra High Interrupting Capacity 600 Vac Rated 100 kAIC at 480 Vac</b>				
800	CND3800T106W	CND3800T107W	400	ORPN80A400
			450	ORPN80A450
			500	ORPN80A500
			550	ORPN80A550
			600	ORPN80A600
			700	ORPN80A700
			800	ORPN80A800
1200	CND312T106W <sup>④</sup>	CND312T107W	600	ORPN12A600
			700	ORPN12A700
			800	ORPN12A800
			1000	ORPN12A100
			1200	ORPN12A120

#### Type ND Molded Case Switches

#### Type ND High Instantaneous (K)

Continuous Ampere Rating at 40 °C	Three-Pole Catalog Number	Four-Pole <sup>⑤</sup> Catalog Number
800	ND3800WK	ND4800WK
	HND3800WK	HND4800WK
1200	ND312WK	ND412WK
	HND312WK	HND412WK

#### Notes

- ① Long delay I<sup>4</sup>t response selection limits short delay time to flat response.
- ② One Form C auxiliary switch one Form C bell (trip) alarm switch supplied with breaker as standard.
- ③ Factory sealed.
- ④ Includes conductor extension kit, which increases breaker length 3.75 on each end. Terminal ordered separate.
- ⑤ Neutral is in right pole.

Molded case switch will trip above 14,000 amperes.

For UL listed, series tested molded case switch application data, refer to Eaton.

## Accessories Selection Guide and Ordering Information

### Line and Load Terminals—Ordering Information

N-Frame circuit breakers use Cu/Al terminals as standard. When optional copper or Cu/Al terminals are required, order by catalog number. Specify if factory installation is required.

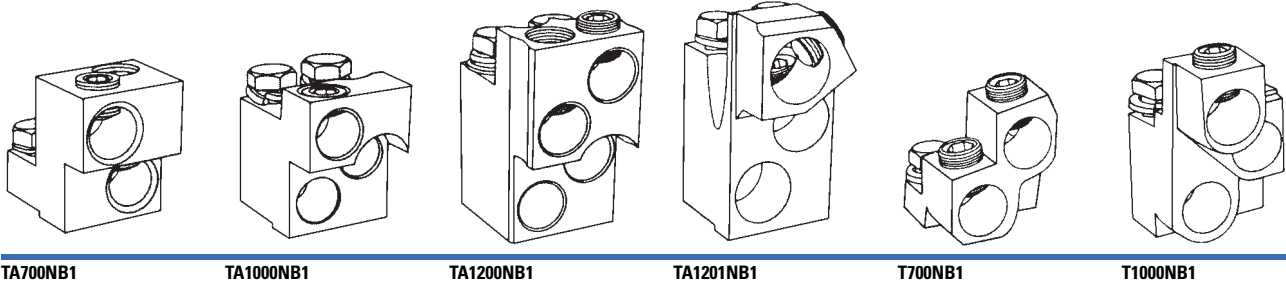

### Line and Load Terminals

Maximum Breaker Amperes	Terminal Body Material	Wire Type	AWG Wire Range/ No. Conductors	Metric Wire Range mm <sup>2</sup>	Catalog Number
<b>Standard Cu/Al Pressure Terminals</b>					
700	Aluminum	Cu/Al	1–500 kcmil (2)	50–240	<b>TA700NB1</b>
1000	Aluminum	Cu/Al	3/0–400 kcmil (3)	95–185	<b>TA1000NB1</b> ①
1200	Aluminum	Cu/Al	4/0–500 kcmil (4)	120–240	<b>TA1200NB1</b> ①
1200	Aluminum	Cu/Al	500–750 kcmil (3)	300–400	<b>TA1201NB1</b> ②
<b>Optional Copper and Cu/Al Pressure Type Terminals</b>					
700	Copper	Cu	2/0–500 kcmil (2)	70–240	<b>T700NB1</b>
1000	Copper	Cu	3/0–500 kcmil (3)	95–240	<b>T1000NB1</b>
1200	Copper	Cu	3/0–400 kcmil (4)	95–185	<b>T1200NB3</b>

#### Notes

① Terminal rating is AL9CU.

② Terminal rating is AL7CU.

### Accessories

#### Allowable Accessory Combinations

Different combinations of accessories can be supplied, depending on the types of accessories and the number of poles in the circuit breaker.

#### ND Frame Accessories

Description	Reference Page	Three-Pole			Four-Pole			Neutral
		Left	Center	Right	Left	Center	Right	
<b>Internal Accessories (Only One Internal Accessory Per Pole) ①</b>								
Alarm lockout (1Make/Break)	V4-T2-276	■		■	■		■	
Alarm lockout (2Make/2Break)	V4-T2-276	■		■	■		■	
Auxiliary switch (1A, 1B)	V4-T2-278	■		■	■		■	
Auxiliary switch (2A, 2B)	V4-T2-278	■		■	■		■	
Auxiliary switch (3A, 3B)	V4-T2-278	■		■	■		■	
Auxiliary switch (1A, 1B) and alarm switch combination	V4-T2-280	■		■	■		■	
Auxiliary switch (2A, 2B) and alarm switch combination	V4-T2-280	■		■	■		■	
Shunt trip—standard	V4-T2-284	■			■			
Shunt trip—low energy	V4-T2-285	■			■			
Undervoltage release mechanism	V4-T2-292	■			■			
Eaton PowerNet communications kit (OPTIM 550)	V4-T2-293			■				
<b>External Accessories</b>								
Base mounting hardware	V4-T2-311	●	●	●	●	●	●	●
Interphase barriers	V4-T2-313	●	●	●	●	●	●	●
Terminal shield	V4-T2-313	■	■	■				
Non-padlockable handle block	V4-T2-314		■			■		
Padlockable handle lock hasp	V4-T2-315	□		□	□		□	
Key interlock kit	V4-T2-316	□		□	□		□	
Sliding bar interlock—requires two breakers	V4-T2-317	●	●	●				
Walking beam interlock—requires two breakers	V4-T2-317	●	●	●	●	●	●	●
Electrical (motor) operator	V4-T2-319	●	●	●	●	●	●	●
Plug-in adapters	V4-T2-320	●	●	●	●	●	●	●
Rear connecting studs	V4-T2-321	●	●	●	●	●	●	●
Panelboard connecting straps	V4-T2-322	●	●	●	●	●	●	●
Handle mechanisms	V4-T2-432	●	●	●	●	●	●	●
Handle extension	V4-T2-447	●	●	●	●	●	●	●
Solid-state (electronic) portable test kit	V4-T2-325	●	●	●	●	●	●	●
<b>OPTIM System Components Three Poles</b>								
Ground fault alarm unit	V4-T2-324							
Potential transformer module	V4-T2-324							
Breaker interface module (BIM)	V4-T2-325							
Digitrip OPTIMizer	V4-T2-325							
Auxiliary power module	V4-T2-325							
<b>Modifications (Refer to Eaton)</b>								
Special calibration	—	●	●	●	●	●	●	●
Moisture fungus treatment	V4-T2-116	●	●	●	●	●	●	●
Freeze-tested circuit breakers	—	●	●	●	●	●	●	●
Marine/naval application	—	●	●	●	●	●	●	●

#### Legend

- Applicable in indicated pole position
- May be mounted on left or right pole—not both
- Accessory available/modification available

#### Note

① OPTIM 550 and 1050 are factory sealed and do not have the right pole available for accessories.

## Technical Data and Specifications

### UL 489 Interrupting Capacity Ratings <sup>①</sup>

Circuit Breaker Type	Number of Poles	Interrupting Capacity (kA Symmetrical Amperes)			
		Volts AC (50/60 Hz)			
		240	277	480	600
ND	2, 3, 4	65	—	50	25
CND <sup>②</sup>	2, 3, 4	65	—	50	25
HND	2, 3, 4	100	—	65	35
CHND <sup>②</sup>	2, 3, 4	100	—	65	35
NDC	2, 3, 4	200	—	100	65
CNDC <sup>②</sup>	2, 3, 4	200	—	100	65
NDU <sup>③</sup>	3	300 <sup>④</sup>	—	150	75 <sup>⑤</sup>

### IEC 947-2 Interrupting Capacity Ratings <sup>①</sup>

Circuit Breaker Type	Number of Poles	Interrupting Capacity (kA Symmetrical Amperes)		
		Volts AC (50/60 Hz)		
		240	415	690
<b>ND</b>				
$I_{CU}$	2, 3, 4	85	50	20
$I_{CS}$	2, 3, 4	85	50	10
<b>CND <sup>②</sup></b>				
$I_{CU}$	2, 3, 4	85	50	20
$I_{CS}$	2, 3, 4	85	50	10
<b>HND</b>				
$I_{CU}$	2, 3, 4	100	70	25
$I_{CS}$	2, 3, 4	100	50	13
<b>CHND <sup>②</sup></b>				
$I_{CU}$	2, 3, 4	100	70	25
$I_{CS}$	2, 3, 4	100	50	13
<b>NDC</b>				
$I_{CU}$	2, 3, 4	200	100	35
$I_{CS}$	2, 3, 4	100	50	18
<b>CNDC <sup>②</sup></b>				
$I_{CU}$	2, 3, 4	200	100	35
$I_{CS}$	2, 3, 4	100	50	18

#### Notes

- ① Utilization Category A circuit breakers.
- ② 100% rated breakers.
- ③ 800 amperes maximum rating.
- ④ Successfully tested at 300 kAIC, although UL recognizes maximum of 200 kAIC at 240 Vac.
- ⑤ Successfully tested at 75 kAIC, although UL recognizes maximum of 65 kAIC at 600 Vac.

## N-Frame Digitrip

Trip Unit Type	Digitrip OPTIM 550	Digitrip OPTIM 1050
rms sensing	Yes	Yes
<b>Breaker Type</b>		
Frame	N	N
Ampere range	400–1200 A	400–1200 A
Interrupting rating at 480 volts	50, 65, 100 (kA)	50, 65, 100 (kA)
<b>Protection</b>		
Ordering options	LSI, LSIG, LSI(A)	LSI(A), LISG
Fixed rated plug ( $I_n$ )	Yes	Yes
Overtemperature trip	Yes	Yes
<b>Long Delay Protection (L)</b>		
Adjustable rating plug ( $I_n$ )	No	No
Long delay pickup	0.4–1.0 x ( $I_n$ )	0.4–1.0 x ( $I_n$ )
Long delay time $I^2t$	2–24 seconds	2–24 seconds
Long delay time $I^4t$	1–5 seconds	1–5 seconds
Long delay thermal memory	Yes	Yes
High load alarm	No	0.5–1.0 x $I_r$
<b>Short Delay Protection (S)</b>		
Short delay pickup	150–800% x ( $I_r$ )	150–800% x ( $I_r$ )
Short delay time $I^2t$	100–500 ms	100–500 ms
Short delay time flat	100–500 ms	100–500 ms
Short delay time zone selective interlocking	Yes	Yes
<b>Instantaneous Protection (I)</b>		
Instantaneous pickup	200–800% x ( $I_n$ )	200–800% x ( $I_n$ )
Discriminator	Yes	Yes
Instantaneous override	Yes	Yes
<b>Ground Fault Protection (G)</b>		
Ground fault alarm	20–100% x ( $I_s$ )	20–100% x ( $I_s$ )
Ground fault pickup	20–100% x ( $I_s$ )	20–100% x ( $I_s$ )
Ground fault delay $I^2t$	100–500 ms	100–500 ms
Ground fault delay flat	100–500 ms	100–500 ms
Ground fault zone selective interlocking	Yes ①	Yes
Ground fault thermal memory	Yes	Yes
<b>System Diagnostics</b>		
Status LEDs	Yes	Yes
Cause of trip LEDs	Yes	Yes
Magnitude of trip information	Yes	Yes
Remote signal contact—ground alarm	Yes ①	Yes
Local auxiliary and bell alarm contact	Optional	Included

**Legend**

BIM = Breaker Interface Module

(A) = GF Alarm

 $I_s$  = Sensor Rating $I_n$  = Rating Plug $I_r$  = Long Delay Pickup Setting**Note**

① Zone interlock kit.

**N-Frame Digitrip, continued**

<b>Trip Unit Type</b>	<b>Digitrip OPTIM 550</b>	<b>Digitrip OPTIM 1050</b>
<b>System Monitoring</b>		
Digital display	Yes <sup>①</sup>	Yes <sup>①</sup>
Current	Yes	Yes
Power and energy	No	Yes
Power quality—harmonics	No	Yes
Power factor	No	Yes
<b>Communications</b>		
Eaton PowerNet	No <sup>②</sup>	Yes
<b>Testing</b>		
Testing method	OPTIMizer, BIM, PowerNet	OPTIMizer, BIM, PowerNet

**Legend**

BIM = Breaker Interface Module  
 (A) = GF Alarm  
 $I_s$  = Sensor Rating  
 $I_n$  = Rating Plug  
 $I_r$  = Long Delay Pickup Setting

**Notes**

- <sup>①</sup> By OPTIMizer/BIM.  
<sup>②</sup> Eaton's PowerNet kit.

# 2.3

## Molded Case Circuit Breakers

### Series C

2

#### Dimensions and Weights

Approximate Dimensions in Inches (mm)

#### ND Frame

Number of Poles	Width	Height	Depth
2, 3	8.25 (209.6)	16.00 (406.4)	5.50 (139.7)
4	11.13 (282.6)	16.00 (406.4)	5.50 (139.7)

#### ND-Frame, Two- and Three-Pole

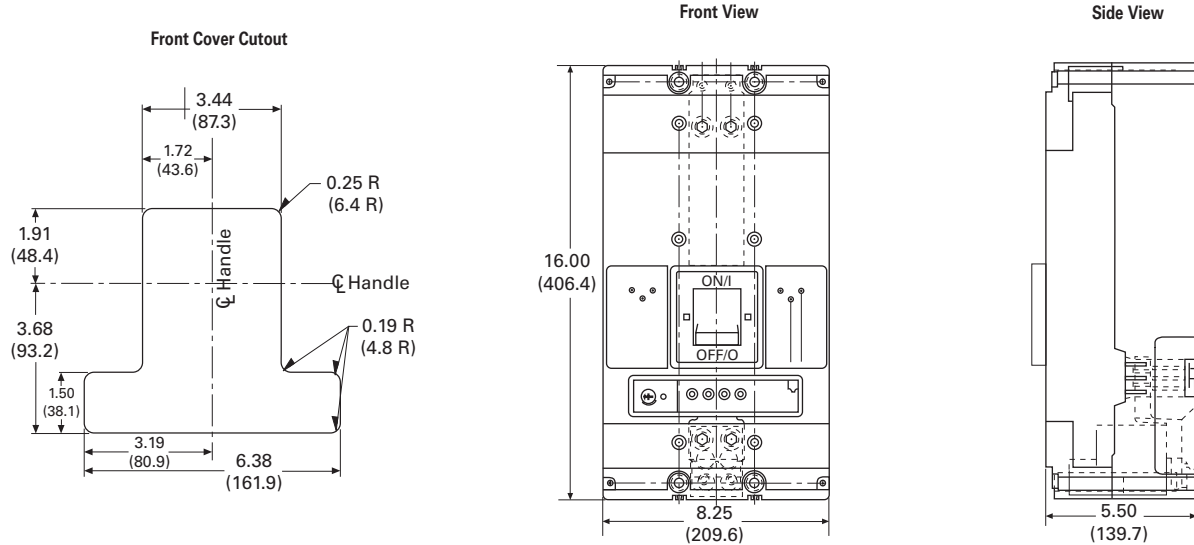

Approximate Shipping Weight in Lbs (kg)

#### ND Frame

Breaker Type	Complete Breaker		
	Two-Pole	Three-Pole	Four-Pole
ND, HND, NDC, NDU	37 (16.8)	45 (20.4)	58 (26.3)

Typical R-Frame Breaker



## Contents

<i>Description</i>	<i>Page</i>
Product Overview . . . . .	V4-T2-116
Standards and Certifications . . . . .	V4-T2-117
Quick Reference . . . . .	V4-T2-118
G-Frame (15–100 Amperes) . . . . .	V4-T2-121
F-Frame (10–225 Amperes) . . . . .	V4-T2-135
J-Frame (70–250 Amperes) . . . . .	V4-T2-153
K-Frame (70–400 Amperes) . . . . .	V4-T2-161
L-Frame (125–600 Amperes) . . . . .	V4-T2-185
M-Frame (300–800 Amperes) . . . . .	V4-T2-211
N-Frame (400–1200 Amperes) . . . . .	V4-T2-222
R-Frame (800–2500 Amperes)	
Catalog Number Selection . . . . .	V4-T2-238
Product Selection . . . . .	V4-T2-239
Accessories . . . . .	V4-T2-251
Technical Data and Specifications . . . . .	V4-T2-252
Dimensions and Weights . . . . .	V4-T2-255
Motor Circuit Protectors (MCP) . . . . .	V4-T2-256
Motor Protection Circuit Breakers (MPCB) . . . . .	V4-T2-267
Type ELC Current Limiter Attachment (Size 0–4) . . . . .	V4-T2-269
Current Limiting Circuit Breaker Module . . . . .	V4-T2-270
Internal Accessories . . . . .	V4-T2-273
External Accessories . . . . .	V4-T2-304

## R-Frame (800–2500 Amperes)

### Product Description

- Eaton R-Frame circuit breakers are available as frame (which includes trip unit), rating plug and terminals
- All R-Frame circuit breakers are suitable for reverse feed use

# 2.3

## Molded Case Circuit Breakers

### Series C

#### Catalog Number Selection

This information is presented only as an aid to understanding catalog numbers. It is not to be used to build catalog numbers for circuit breakers or trip units.

2

#### Circuit Breaker/Frame

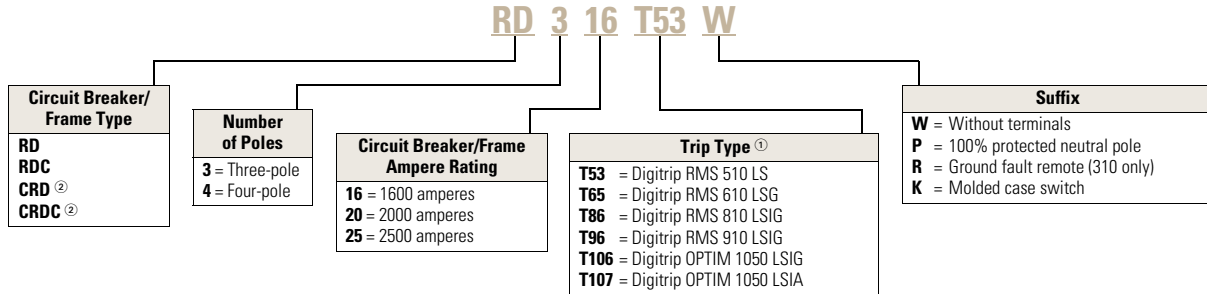

#### Notes

- ① For complete list of available trip types, refer to **Pages V4-T2-239 to V4-T2-248**.
- ② No four-pole for CRD and CRDC.

## Product Selection

### Digitrip RMS 510 Electronic Circuit Breakers with Interchangeable Rating Plugs

Order as individual components: breaker frame (which includes trip unit) and rating plug.

### Digitrip RMS 510 Electronic Circuit Breakers with Interchangeable Rating Plugs

Maximum Continuous Ampere Rating at 40 °C	Circuit Breaker Frame Only						Digitrip Rating Plug Only	
	L – Adjustable Long Delay Pickup ( $I_L$ ) with Adjustable Long Delay Time S – Adjustable Short Delay Pickup with Adjustable Short Delay Time ( $I^2t$ or Flat Response) I – Adjustable Instantaneous Pickup G – Adjustable Ground Fault Pickup with Adjustable Ground Fault Time Delay ( $I^2t$ or Flat Response)						Rated Current ( $I_n$ )	Fixed Rating Plug Catalog Number
	LI	LS	LSI	LIG	LSG	LSIG		
Catalog Number								
<b>Three-Pole Standard Interrupting Capacity 600 Vac Rated 65 kAIC at 480 Vac</b>								
1600	RD316T51W	RD316T53W	RD316T52W	RD316T54W	RD316T55W	RD316T56W	800	RP6R16A080
							1000	RP6R16A100
							1200	RP6R16A120
							1600	RP6R16A160
2000	RD320T51W	RD320T53W	RD320T52W	RD320T54W	RD320T55W	RD320T56W	1000	RP6R20A100
							1200	RP6R20A120
							1600	RP6R20A160
							2000	RP6R20A200
2500	RD325T51W	RD325T53W	RD325T52W	RD325T54W	RD325T55W	RD325T56W	1600	RP6R25A160
							2000	RP6R25A200
							2500	RP6R25A250
<b>Three-Pole High Interrupting Capacity 600 Vac Rated 100 kAIC at 480 Vac</b>								
1600	RDC316T51W	RDC316T53W	RDC316T52W	RDC316T54W	RDC316T55W	RDC316T56W	800	RP6R16A080
							1000	RP6R16A100
							1200	RP6R16A120
							1600	RP6R16A160
2000	RDC320T51W	RDC320T53W	RDC320T52W	RDC320T54W	RDC320T55W	RDC320T56W	1000	RP6R20A100
							1200	RP6R20A120
							1600	RP6R20A160
							2000	RP6R20A200
2500	RDC325T51W	RDC325T53W	RDC325T52W	RDC325T54W	RDC325T55W	RDC325T56W	1600	RP6R25A160
							2000	RP6R25A200
							2500	RP6R25A250

# 2.3

## Molded Case Circuit Breakers

### Series C

#### 100% Rated Digitrip RMS 510 Circuit Breakers

The NEC allows the breaker to be rated at 100% of its frame size in an assembly, provided that 90 °C wire is applied at 75 °C ampacity. Order as individual components: breaker frame (which includes trip unit) and rating plug.

2

#### 100% Rated Digitrip RMS 510 Circuit Breakers

Maximum Continuous Ampere Rating at 40 °C	Circuit Breaker Frame Only						Digitrip Rating Plug Only	
	L LI	S LS	I LSI	G LIG	LSG	LSIG	Rated Current (I <sub>n</sub> )	Fixed Rating Plug Catalog Number
<b>Three-Pole Standard Interrupting Capacity 600 Vac Rated 65 kAIC at 480 Vac</b>								
1600	CRD316T51W	CRD316T53W	CRD316T52W	CRD316T54W	CRD316T55W	CRD316T56W	800	RP6R16A080
							1000	RP6R16A100
							1200	RP6R16A120
							1600	RP6R16A160
2000 <sup>①</sup>	CRD320T51W	CRD320T53W	CRD320T52W	CRD320T54W	CRD320T55W	CRD320T56W	1000	RP6R20A100
							1200	RP6R20A120
							1600	RP6R20A160
							2000	RP6R20A200
<b>Three-Pole High Interrupting Capacity 600 Vac Rated 100 kAIC at 480 Vac</b>								
1600	—	CRDC316T53W	CRDC316T52W	CRDC316T54W	CRDC316T55W	CRDC316T56W	800	RP6R16A080
							1000	RP6R16A100
							1200	RP6R16A120
							1600	RP6R16A160
2000 <sup>①</sup>	CRDC320T51W	CRDC320T53W	CRDC320T52W	CRDC320T54W	CRDC320T55W	CRDC320T56W	1000	RP6R20A100
							1200	RP6R20A120
							1600	RP6R20A160
							2000	RP6R20A200

**Note**

① Includes B2016RDL rear connectors.

**Digitrip RMS 610 Electronic Circuit Breakers with Interchangeable Rating Plugs**

Order as individual components: breaker frame (which includes trip unit) and rating plug.

**Digitrip RMS 610 Electronic Circuit Breakers with Interchangeable Rating Plugs**

Maximum Continuous Ampere Rating at 40 °C	Circuit Breaker Frame Only						Digitrip Rating Plug Only				
	L – Adjustable Long Delay Pickup ( $I_L$ ) with Adjustable Long Delay Time						Rated Current ( $I_n$ )	Fixed Rating Plug Catalog Number			
	S – Adjustable Short Delay Pickup with Adjustable Short Delay Time ( $I^2t$ or Flat Response)										
I – Adjustable Instantaneous Pickup						LI	LS	LSI	LIG	LSG	LSIG
G – Adjustable Ground Fault Pickup with Adjustable Ground Fault Time Delay ( $I^2t$ or Flat Response)											
Catalog Number											
<b>Three-Pole Standard Interrupting Capacity 600 Vac Rated 65 kAIC at 480 Vac</b>											
1600	RD316T61W	RD316T63W	RD316T62W	RD316T64W	RD316T65W	RD316T66W	800	RP6R16A080			
							1000	RP6R16A100			
							1200	RP6R16A120			
							1600	RP6R16A160			
2000	RD320T61W	RD320T63W	RD320T62W	RD320T64W	RD320T65W	RD320T66W	1000	RP6R20A100			
							1200	RP6R20A120			
							1600	RP6R20A160			
							2000	RP6R20A200			
2500	RD325T61W	RD325T63W	RD325T62W	RD325T64W	RD325T65W	RD325T66W	1600	RP6R25A160			
							2000	RP6R25A200			
							2500	RP6R25A250			
<b>Three-Pole High Interrupting Capacity 600 Vac Rated 100 kAIC at 480 Vac</b>											
1600	RDC316T61W	RDC316T63W	RDC316T62W	RDC316T64W	RDC316T65W	RDC316T66W	800	RP6R16A080			
							1000	RP6R16A100			
							1200	RP6R16A120			
							1600	RP6R16A160			
2000	RDC320T61W	RDC320T63W	RDC320T62W	RDC320T64W	RDC320T65W	RDC320T66W	1000	RP6R20A100			
							1200	RP6R20A120			
							1600	RP6R20A160			
							2000	RP6R20A200			
2500	RDC325T61W	RDC325T63W	RDC325T62W	RDC325T64W	RDC325T65W	RDC325T66W	1600	RP6R25A160			
							2000	RP6R25A200			
							2500	RP6R25A250			

# 2.3

## Molded Case Circuit Breakers

### Series C

#### 100% Rated Digitrip RMS 610 Circuit Breakers

The NEC allows the breaker to be rated at 100% of its frame size in an assembly, provided that 90 °C wire is applied at 75 °C ampacity. Order as individual components: breaker frame (which includes trip unit) and rating plug.

2

#### 100% Rated Digitrip RMS 610 Circuit Breakers

Maximum Continuous Ampere Rating at 40 °C	Circuit Breaker Frame Only						Digitrip Rating Plug Only	
	LI	LS	LSI	LIG	LSG	LSIG	Rated Current (I <sub>n</sub> )	Fixed Rating Plug Catalog Number
	<b>L – Adjustable Long Delay Pickup (I<sub>l</sub>) with Adjustable Long Delay Time</b> <b>S – Adjustable Short Delay Pickup with Adjustable Short Delay Time (I<sup>2</sup>t or Flat Response)</b> <b>I – Adjustable Instantaneous Pickup</b> <b>G – Adjustable Ground Fault Pickup with Adjustable Ground Fault Time Delay (I<sup>2</sup>t or Flat Response)</b>							
	<b>LI                      LS                      LSI                      LIG                      LSG                      LSIG</b> <b>Catalog Number</b>							
<b>Three-Pole Standard Interrupting Capacity 600 Vac Rated 65 kAIC at 480 Vac</b>								
1600	CRD316T61W	CRD316T63W	CRD316T62W	CRD316T64W	CRD316T65W	CRD316T66W	800	RP6R16A080
							1000	RP6R16A100
							1200	RP6R16A120
							1600	RP6R16A160
2000 <sup>①</sup>	CRD320T61W	CRD320T63W	CRD320T62W	CRD320T64W	CRD320T65W	CRD320T66W	1000	RP6R20A100
							1200	RP6R20A120
							1600	RP6R20A160
							2000	RP6R20A200
<b>Three-Pole High Interrupting Capacity 600 Vac Rated 100 kAIC at 480 Vac</b>								
1600	CRDC316T61W	CRDC316T63W	CRDC316T62W	CRDC316T64W	CRDC316T65W	CRDC316T66W	800	RP6R16A080
							1000	RP6R16A100
							1200	RP6R16A120
							1600	RP6R16A160
2000 <sup>①</sup>	CRDC320T61W	CRDC320T63W	CRDC320T62W	CRDC320T64W	CRDC320T65W	CRDC320T66W	1000	RP6R20A100
							1200	RP6R20A120
							1600	RP6R20A160
							2000	RP6R20A200

**Note**

<sup>①</sup> Includes B2016RDL rear connectors.

**Digitrip RMS 810 Electronic Circuit Breakers with Interchangeable Rating Plugs**

Order as individual components: breaker frame (which includes trip unit) and rating plug.

**Digitrip RMS 810 Electronic Circuit Breakers with Interchangeable Rating Plugs**

Maximum Continuous Ampere Rating at 40 °C	Circuit Breaker Frame Only						Digitrip Rating Plug Only	
	L – Adjustable Long Delay Pickup ( $I_L$ ) with Adjustable Long Delay Time S – Adjustable Short Delay Pickup with Adjustable Short Delay Time ( $I^2t$ or Flat Response) I – Adjustable Instantaneous Pickup G – Adjustable Ground Fault Pickup with Adjustable Ground Fault Time Delay ( $I^2t$ or Flat Response)						Rated Current ( $I_n$ )	Fixed Rating Plug Catalog Number
	LI	LS	LSI	LIG	LSG	LSIG		
Catalog Number								
<b>Three-Pole Standard Interrupting Capacity 600 Vac Rated 65 kAIC at 480 Vac</b>								
1600	RD316T81W	RD316T83W	RD316T82W	RD316T84W	RD316T85W	RD316T86W	800	RP6R16A080
							1000	RP6R16A100
							1200	RP6R16A120
							1600	RP6R16A160
2000	RD320T81W	RD320T83W	RD320T82W	RD320T84W	RD320T85W	RD320T86W	1000	RP6R20A100
							1200	RP6R20A120
							1600	RP6R20A160
							2000	RP6R20A200
2500	RD325T81W	RD325T83W	RD325T82W	RD325T84W	RD325T85W	RD325T86W	1600	RP6R25A160
							2000	RP6R25A200
							2500	RP6R25A250
<b>Three-Pole High Interrupting Capacity 600 Vac Rated 100 kAIC at 480 Vac</b>								
1600	RDC316T81W	RDC316T83W	RDC316T82W	RDC316T84W	RDC316T85W	RDC316T86W	800	RP6R16A080
							1000	RP6R16A100
							1200	RP6R16A120
							1600	RP6R16A160
2000	RDC320T81W	RDC320T83W	RDC320T82W	RDC320T84W	RDC320T85W	RDC320T86W	1000	RP6R20A100
							1200	RP6R20A120
							1600	RP6R20A160
							2000	RP6R20A200
2500	RDC325T81W	RDC325T83W	RDC325T82W	RDC325T84W	RDC325T85W	RDC325T86W	1600	RP6R25A160
							2000	RP6R25A200
							2500	RP6R25A250

# 2.3

## Molded Case Circuit Breakers

### Series C

#### 100% Rated Digitrip RMS 810 Circuit Breakers

The NEC allows the breaker to be rated at 100% of its frame size in an assembly, provided that 90 °C wire is applied at 75 °C ampacity. Order as individual components: breaker frame (which includes trip unit) and rating plug.

2

#### 100% Rated Digitrip RMS 810 Circuit Breakers

Maximum Continuous Ampere Rating at 40 °C	Circuit Breaker Frame Only						Digitrip Rating Plug Only	
	L LI Catalog Number	S LS	I LSI	G LIG		LSG	Rated Current (I <sub>n</sub> )	Fixed Rating Plug Catalog Number
<b>Three-Pole Standard Interrupting Capacity 600 Vac Rated 65 kAIC at 480 Vac</b>								
1600	CRD316T81W	CRD316T83W	CRD316T82W	CRD316T84W	CRD316T85W	CRD316T86W	800	RP6R16A080
							1000	RP6R16A100
							1200	RP6R16A120
							1600	RP6R16A160
2000 <sup>Ⓢ</sup>	CRD320T81W	CRD320T83W	CRD320T82W	CRD320T84W	CRD320T85W	CRD320T86W	1000	RP6R20A100
							1200	RP6R20A120
							1600	RP6R20A160
							2000	RP6R20A200
<b>Three-Pole High Interrupting Capacity 600 Vac Rated 100 kAIC at 480 Vac</b>								
1600	CRDC316T81W	CRDC316T83W	CRDC316T82W	CRDC316T84W	CRDC316T85W	CRDC316T86W	800	RP6R16A080
							1000	RP6R16A100
							1200	RP6R16A120
							1600	RP6R16A160
2000 <sup>Ⓢ</sup>	CRDC320T81W	CRDC320T83W	CRDC320T82W	CRDC320T84W	CRDC320T85W	CRDC320T86W	1000	RP6R20A100
							1200	RP6R20A120
							1600	RP6R20A160
							2000	RP6R20A200

**Note**

<sup>Ⓢ</sup> Includes B2016RDL rear connectors.

**Digitrip RMS 910 Electronic Circuit Breakers with Interchangeable Rating Plugs**

Order as individual components: breaker frame (which includes trip unit) and rating plug.

**Digitrip RMS 910 Electronic Circuit Breakers with Interchangeable Rating Plugs**

Maximum Continuous Ampere Rating at 40 °C	Circuit Breaker Frame Only						Digitrip Rating Plug Only	
	LI	LS	LSI	LIG	LSG	LSIG	Rated Current (I <sub>n</sub> )	Fixed Rating Plug Catalog Number
<b>Three-Pole Standard Interrupting Capacity 600 Vac Rated 65 kAIC at 480 Vac</b>								
1600	RD316T91W	RD316T93W	RD316T92W	RD316T94W	RD316T95W	RD316T96W	800	RP6R16A080
							1000	RP6R16A100
							1200	RP6R16A120
							1600	RP6R16A160
2000	RD320T91W	RD320T93W	RD320T92W	RD320T94W	RD320T95W	RD320T96W	1000	RP6R20A100
							1200	RP6R20A120
							1600	RP6R20A160
							2000	RP6R20A200
2500	RD325T91W	RD325T93W	RD325T92W	RD325T94W	RD325T95W	RD325T96W	1600	RP6R25A160
							2000	RP6R25A200
							2500	RP6R25A250
<b>Three-Pole High Interrupting Capacity 600 Vac Rated 100 kAIC at 480 Vac</b>								
1600	RDC316T91W	RDC316T93W	RDC316T92W	RDC316T94W	RDC316T95W	RDC316T96W	800	RP6R16A080
							1000	RP6R16A100
							1200	RP6R16A120
							1600	RP6R16A160
2000	RDC320T91W	RDC320T93W	RDC320T92W	RDC320T94W	RDC320T95W	RDC320T96W	1000	RP6R20A100
							1200	RP6R20A120
							1600	RP6R20A160
							2000	RP6R20A200
2500	RDC325T91W	RDC325T93W	RDC325T92W	RDC325T94W	RDC325T95W	RDC325T96W	1600	RP6R25A160
							2000	RP6R25A200
							2500	RP6R25A250

# 2.3

## Molded Case Circuit Breakers

### Series C

#### 100% Rated Digitrip RMS 910 Circuit Breakers

The NEC allows the breaker to be rated at 100% of its frame size in an assembly, provided that 90 °C wire is applied at 75 °C ampacity. Order as individual components: breaker frame (which includes trip unit) and rating plug.

2

#### 100% Rated Digitrip RMS 910 Circuit Breakers

Maximum Continuous Ampere Rating at 40 °C	Circuit Breaker Frame Only						Digitrip Rating Plug Only					
	L Adjustable Long Delay Pickup (I <sub>1</sub> ) with Adjustable Long Delay Time	S Adjustable Short Delay Pickup with Adjustable Short Delay Time (I <sup>2</sup> t or Flat Response)	I Adjustable Instantaneous Pickup	G Adjustable Ground Fault Pickup with Adjustable Ground Fault Time Delay (I <sup>2</sup> t or Flat Response)	LI	LS	LSI	LIG	LSG	LSIG	Rated Current (I <sub>n</sub> )	Fixed Rating Plug Catalog Number
<b>Three-Pole Standard Interrupting Capacity 600 Vac Rated 65 kAIC at 480 Vac</b>												
1600	CRD316T91W	CRD316T93W	CRD316T92W	CRD316T94W	CRD316T95W	CRD316T96W	800	RP6R16A080				
							1000	RP6R16A100				
							1200	RP6R16A120				
							1600	RP6R16A160				
2000 <sup>①</sup>	CRD320T91W	CRD320T93W	CRD320T92W	CRD320T94W	CRD320T95W	CRD320T96W	1000	RP6R20A100				
							1200	RP6R20A120				
							1600	RP6R20A160				
							2000	RP6R20A200				
<b>Three-Pole High Interrupting Capacity 600 Vac Rated 100 kAIC at 480 Vac</b>												
1600	CRDC316T91W	CRDC316T93W	CRDC316T92W	CRDC316T94W	CRDC316T95W	CRDC316T96W	800	RP6R16A080				
							1000	RP6R16A100				
							1000	RP6R16A100				
							1200	RP6R16A120				
2000 <sup>①</sup>	CRDC320T91W	CRDC320T93W	CRDC320T92W	CRDC320T94W	CRDC320T95W	CRDC320T96W	1000	RP6R20A100				
							1200	RP6R20A120				
							1600	RP6R20A160				
							2000	RP6R20A200				

**Note**

① Includes B2016RDL rear connectors.

**Digitrip OPTIM Electronic Circuit Breakers with Interchangeable Rating Plugs**

Order as individual components: breaker frame (which includes trip unit) and rating plug.

**Digitrip OPTIM Electronic Circuit Breakers with Interchangeable Rating Plugs**

Maximum Continuous Ampere Rating at 40 °C	Circuit Breaker Frame Only		Digitrip OPTIM Rating Plug Only	
	LSIA 1050 Catalog Number	LSIG 1050 Catalog Number	Ampere Rating	Fixed Rating Plug Catalog Number
<b>Three-Pole Standard Interrupting Capacity 600 Vac Rated 65 kAIC at 480 Vac</b>				
1600	RD316T107W	RD316T106W	800	ORPR16A080
			1000	ORPR16A100
			1200	ORPR16A120
			1600	ORPR16A160
2000	RD320T107W	RD320T106W	1000	ORPR20A100
			1200	ORPR20A120
			1600	ORPR20A160
			2000	ORPR20A200
2500	RD325T107W	RD325T106W	1600	ORPR25A160
			2000	ORPR25A200
			2500	ORPR25A250
<b>Three-Pole High Interrupting Capacity 600 Vac Rated 100 kAIC at 480 Vac</b>				
1600	RDC316T107W	RDC316T106W	800	ORPR16A080
			1000	ORPR16A100
			1200	ORPR16A120
			1600	ORPR16A160
2000	RDC320T107W	RDC320T106W	1000	ORPR20A100
			1200	ORPR20A120
			1600	ORPR20A160
			2000	ORPR20A200
2500	RDC325T107W	RDC325T106W	1600	ORPR25A160
			2000	ORPR25A200
			2500	ORPR25A250

# 2.3

## Molded Case Circuit Breakers

### Series C

#### 100% Rated 600 Volts AC Digitrip OPTIM Circuit Breakers with Interchangeable Rating Plugs

Order as individual components: breaker frame (which includes trip unit) and rating plug.

2

#### 100% Rated 600 Volts AC Digitrip OPTIM Circuit Breakers with Interchangeable Rating Plugs

Maximum Continuous Ampere Rating at 40 °C	Circuit Breaker Frame Only		Digitrip OPTIM Rating Plug Only	
	LSIA 1050 Catalog Number	LSIG 1050 Catalog Number	Ampere Rating	Fixed Rating Plug Catalog Number
<b>Three-Pole Standard Interrupting Capacity 600 Vac Rated 65 kAIC at 480 Vac</b>				
1600	CRD316T107W	CRD316T106W	800	ORPR16A080
			1000	ORPR16A100
			1200	ORPR16A120
			1600	ORPR16A160
2000 <sup>①</sup>	CRD320T107W	CRD320T106W	1000	ORPR20A100
			1200	ORPR20A120
			1600	ORPR20A160
			2000	ORPR20A200
<b>Three-Pole High Interrupting Capacity 600 Vac Rated 100 kAIC at 480 Vac</b>				
1600	CRDC316T107W	CRDC316T106W	800	ORPR16A080
			1000	ORPR16A100
			1200	ORPR16A120
			1600	ORPR16A160
2000 <sup>①</sup>	CRDC320T107W	CRDC320T106W	1000	ORPR20A100
			1200	ORPR20A120
			1600	ORPR20A160
			2000	ORPR20A200

#### Molded Case Switches

Refer to Eaton for UL listed, series tested Molded Case Switch application data.

#### Type RD—High Instantaneous (K)

Continuous Ampere Rating at 40 °C	Complete without Terminals	
	Three-Pole Catalog Number	Four-Pole Catalog Number
1600	RD316WK	RD416WK
2000	RD320WK	RD420WK

#### Notes

<sup>①</sup> Includes B2016RDL rear connectors.

Molded case switch may trip above 17,500 amperes.

## Accessories Selection Guide and Ordering Information

### Line and Load Terminals

Line and load terminals provide wire connecting capabilities for specific ranges of continuous current ratings and wire types. All terminals comply with Underwriters Laboratories Standards UL 486A and UL 486B and CSA C22.2 No. 65M. Unless otherwise specified, R-Frame circuit breaker line load terminals are shipped separately for field installation.

### Ordering Information

R-Frame circuit breakers have Cu/Al terminals as standard and Cu only terminals as an option. Specify if factory installation is required.

### Line and Load Terminals

Maximum Breaker Amperes	Terminal Body Material	Wire Type	Hardware	AWG/kcmil Wire Range/ No. Conductors	Metric Wire Range mm <sup>2</sup>	Catalog Number
<b>Wire Terminals</b>						
1600	Aluminum	Cu/Al	English	500–1000 (4)	300–500	<b>TA1600RD</b>
1600	Copper	Cu	English	1–600 (4)	50–300	<b>T1600RD</b>
2000	Aluminum	Cu/Al	English	2–600 (6)	35–300	<b>TA2000RD</b> <sup>①</sup>
<b>Rear Connectors</b>						
2000	Copper	—	English	—	—	<b>B2016RD</b>
2000	Copper	—	English	—	—	<b>B2016RDL</b> <sup>②</sup>
2500	Copper	—	English	—	—	<b>B2500RD</b> <sup>③</sup>

### Notes

- ① Catalog Number includes bus connection, terminals and hardware for either line side or load side of three-pole breaker.
- ② For use with 100% rated 1600 A and 2000 A frame. Do not order separately unless for replacement purposes. Included in breaker carton when 100% rated device is ordered.
- ③ For use with 2500 A frame. Do not order separately unless for replacement purposes. Included in breaker carton when 2500 A breaker is ordered.

# 2.3

## Molded Case Circuit Breakers

### Series C

#### Mounting Hardware

2

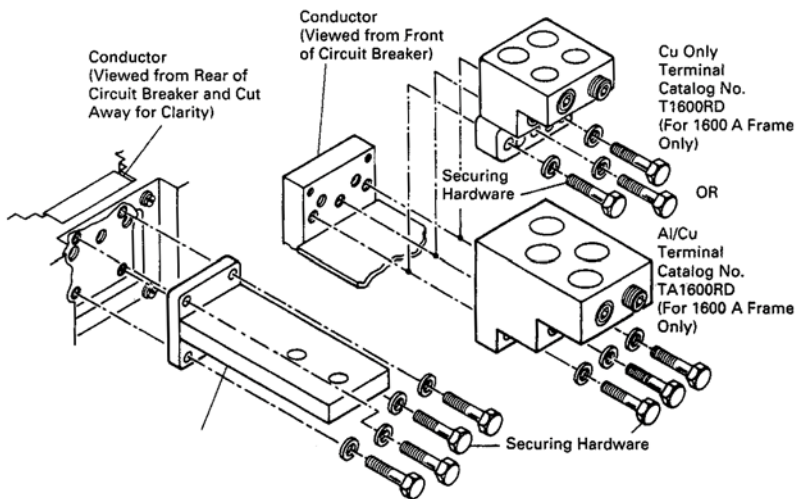
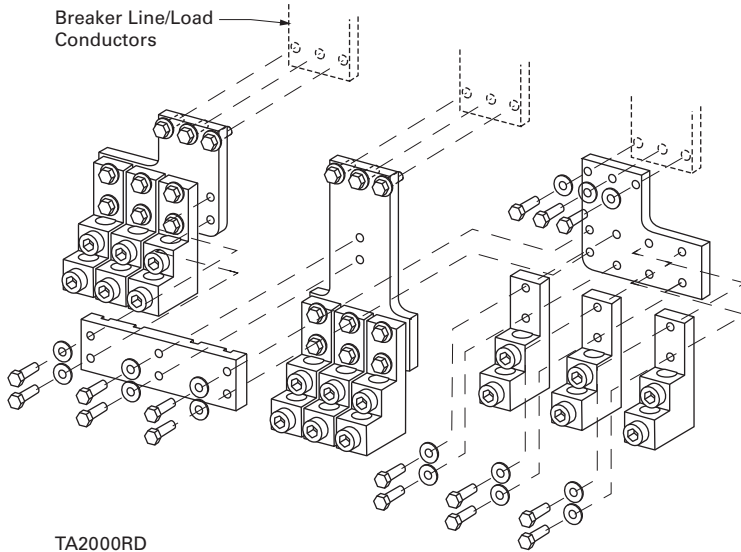

## Accessories

### Allowable Accessory Combinations

Different combinations of accessories can be supplied, depending on the types of accessories and the number of poles in the circuit breaker.

### RD Frame Accessories

Description	Reference Page	Three-Pole Left	Center	Right	Four-Pole Left	Center	Right	Neu.
<b>Internal Accessories</b> <sup>①</sup>								
Alarm lockout (Make/Break)	V4-T2-276			■			■	
Alarm lockout (2Make/2Break)	V4-T2-276			■			■	
Auxiliary switch (2A, 2B)	V4-T2-276			■			■	
Auxiliary switch (4A, 4B)	V4-T2-276			■			■	
Shunt trip—standard	V4-T2-284			■			■	
Shunt trip—low energy	V4-T2-285			■			■	
Undervoltage release mechanism	V4-T2-292			■			■	
Accessory terminal block <sup>②</sup>	V4-T2-293			■				■
<b>External Accessories</b>								
Base mounting hardware	V4-T2-311							
Padlockable handle lock hasp	V4-T2-314		●			●		
Key interlock kit	V4-T2-316	■	■	■		■		
Walking beam interlock	V4-T2-317							
Electrical (motor) operator	V4-T2-319	■	■	■		■		
Handle mechanisms	V4-T2-432	■	■	■		■		
Handle extension <sup>③</sup>	V4-T2-447		■			■		
<b>OPTIM System Components</b>								
Breaker interface module (BIM)	V4-T2-325	●	●	●				
Digitrip OPTIMizer	V4-T2-325	●	●	●				
Auxiliary power module	V4-T2-325	●	●	●				
<b>Modifications (Refer to Eaton)</b>								
Special calibration	—	●	●	●	●	●	●	●
Moisture fungus treatment	V4-T2-116	●	●	●	●	●	●	●
Freeze-tested circuit breakers	—	●	●	●	●	●	●	●
Marine/naval application	—	●	●	●	●	●	●	●

#### Legend

- Applicable in indicated pole position
- Accessory available/modification available

#### Notes

- ① All accessories mount in the RH cavity which will accept one each shunt trip, UVR, auxiliary switch and alarm switch.
- ② Mounts outside breaker.
- ③ Included with breaker.

## Technical Data and Specifications

## 2

### UL 489/CSA Interrupting Capacity Ratings <sup>①</sup>

Circuit Breaker Type	Number of Poles	Interrupting Capacity (kA Symmetrical Amperes)			
		Volts AC (50/60 Hz)			
		240	277	480	600
RD	3, 4	125	—	65	50
CRD <sup>②</sup>	3	125	—	65	50
RDC	3, 4	200	—	100	65
CRDC <sup>②</sup>	3	200	—	100	65

### IEC 947-2 Interrupting Capacity Ratings <sup>①</sup>

Circuit Breaker Type	Number of Poles	Interrupting Capacity (kA Symmetrical Amperes)		
		Volts AC (50/60 Hz)		
		240	415	690
<b>RD</b>				
$I_{CU}$	3, 4	135	70	25
$I_{CS}$	3, 4	100	50	13
<b>RDC</b>				
$I_{CU}$	3, 4	200	100	35
$I_{CS}$	3, 4	100	50	18

#### Notes

<sup>①</sup> Utilization Category A circuit breakers.

<sup>②</sup> 100% rated breakers.

See **Page V4-T2-253** for Trip Unit Specifications.

**Specifications****R-Frame Digitrip**

Trip Unit Type	Digitrip RMS 510	Digitrip RMS 610	Digitrip RMS 810	Digitrip RMS 910	Digitrip OPTIM 1050
rms sensing	Yes	Yes	Yes	Yes	Yes
<b>Breaker Type</b>					
Frame	R	R	R	R	R
Ampere range	800–2500 A	800–2500 A	800–2500 A	800–2500 A	800–2500 A
Interrupting rating at 480 volts	65, 100 (kA)	65, 100 (kA)	65, 100 (kA)	65, 100 (kA)	65, 100 (kA)
<b>Protection</b>					
Ordering options	LI, LS, LSI, LIG, LSG, LSIG	LI, LS, LSI, LIG, LSG, LSIG	LI, LS, LSI, LIG, LSG, LSIG	LI, LS, LSI, LIG, LSG, LSIG	LSI(A), LISG
Fixed rated plug ( $I_n$ )	Yes	Yes	Yes	Yes	Yes
Overtemperature trip	Yes	Yes	Yes	Yes	Yes
<b>Long Delay Protection (L)</b>					
Adjustable rating plug ( $I_n$ )	No	No	No	No	No
Long delay pickup	0.5–1.0 x ( $I_n$ )	0.5–1.0 x ( $I_n$ )	0.5–1.0 x ( $I_n$ )	0.5–1.0 x ( $I_n$ )	0.4–1.0 x ( $I_n$ )
Long delay time $I^2t$	2–24 seconds	2–24 seconds	2–24 seconds	2–24 seconds	2–24 seconds
Long delay time $I^4t$	No	No	No	No	1–5 Seconds
Long delay thermal memory	Yes	Yes	Yes	Yes	Yes
High load alarm	No	0.85 x $I_r$	0.85 x $I_r$	0.85 x $I_r$	0.5–1.0 x $I_r$
<b>Short Delay Protection (S)</b>					
Short delay pickup	200–600% S1 and S2 x ( $I_r$ )	200–600% S1 and S2 x ( $I_r$ )	200–600% S1 and S2 x ( $I_r$ )	200–600% S1 and S2 x ( $I_r$ )	150–800% x ( $I_r$ ) <sup>①②</sup>
Short delay time $I^2t$	100–500 ms	100–500 ms	100–500 ms	100–500 ms	100–500 ms
Short delay time flat	100–500 ms	100–500 ms	100–500 ms	100–500 ms	100–500 ms
Short delay time zone selective interlocking	Yes	Yes	Yes	Yes	Yes
<b>Instantaneous Protection (I)</b>					
Instantaneous pickup	200–600% M1 and M2 x ( $I_n$ )	200–600% M1 and M2 x ( $I_n$ )	200–600% M1 and M2 x ( $I_n$ )	200–600% M1 and M2 x ( $I_n$ )	200–800% x ( $I_n$ ) <sup>②</sup>
Discriminator	Yes <sup>③</sup>	Yes <sup>③</sup>	Yes <sup>③</sup>	Yes <sup>③</sup>	Yes
Instantaneous override	Yes	Yes	Yes	Yes	Yes
<b>Ground Fault Protection (G)</b>					
Ground fault alarm <sup>④</sup>	No	No	No	No	25–100% x ( $I_n$ )
Ground fault pickup <sup>④</sup>	25–100% x ( $I_g$ )	25–100% x ( $I_g$ )	25–100% x ( $I_g$ )	25–100% x ( $I_g$ )	25–100% x ( $I_n$ )
Ground fault delay $I^2t$	100–500 ms	100–500 ms	100–500 ms	100–500 ms	100–500 ms
Ground fault delay flat	100–500 ms	100–500 ms	100–500 ms	100–500 ms	100–500 ms
Ground fault zone selective interlocking	Yes	Yes	Yes	Yes	Yes
Ground fault thermal memory	Yes	Yes	Yes	Yes	Yes

**Legend**

BIM = Breaker Interface Module  
(A) = GF Alarm  
 $I_s$  = Sensor Rating  
 $I_n$  = Rating Plug  
 $I_r$  = Long Delay Pickup Setting x  $I_n$

**Notes**

- ① Except 2500 ampere frame is 200–600%.  
② Varies by frame.  
③ LS/LSG only.  
④ Not to exceed 1200 amperes.

## R-Frame Digitrip, continued

2

Trip Unit Type	Digitrip RMS 510	Digitrip RMS 610	Digitrip RMS 810	Digitrip RMS 910	Digitrip OPTIM 1050
<b>System Diagnostics</b>					
Status LEDs	Yes	Yes	Yes	Yes	Yes
Cause of trip LEDs	Yes	Yes	Yes	Yes	Yes
Magnitude of trip information	No	Yes	Yes	Yes	Yes
Remote signal contacts	No	Yes	Yes	Yes	Yes
<b>System Monitoring</b>					
Digital display	No	Yes	Yes	Yes	Yes <sup>①</sup>
Current	No	Yes	Yes	Yes	Yes
Voltage	No	No	No	Yes	No
Power and energy	No	No	Yes	Yes	Yes
Power quality—harmonics	No	No	No	Yes	Yes
Power factor	No	No	Yes (over Eaton PowerNet only)	Yes	Yes
<b>Communications</b>					
Eaton PowerNet	No	No	Yes	Yes	Yes
<b>Testing</b>					
Testing method	Integral	Integral	Integral	Integral	OPTIMizer, BIM, PowerNet

**Legend**

BIM = Breaker Interface Module  
 (A) = GF Alarm  
 $I_s$  = Sensor Rating  
 $I_n$  = Rating Plug  
 $I_r$  = Long Delay Pickup Setting x  $I_n$

**Note**

<sup>①</sup> By OPTIMizer/BIM.

**Dimensions and Weights**

Dimensions in Inches (mm)

**RD Frame**

Number of Poles	Width	Height	Depth
3	15.50 (393.7)	16.00 (406.4)	9.75 (247.7)
4	20.00 (508.0)	16.00 (406.4)	9.75 (247.7)

**RD-Frame, Three-Pole, 1600 and 2000 Amperes**

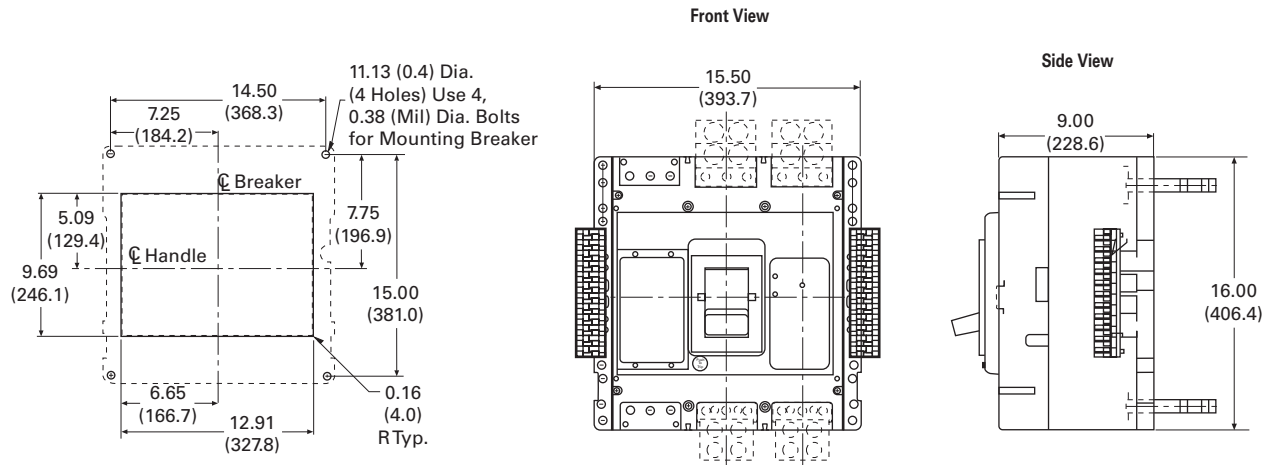

Approximate Shipping Weight in Lbs (kg)

**RD Frame**

Breaker Type	Complete Breaker	
	Three-Pole	Four-Pole
<b>1600 Amperes</b>		
RD, CRD <sup>Ⓢ</sup> , RDC, CRDC <sup>Ⓢ</sup>	102 (46.3)	135 (61.2)
<b>2000 Amperes</b>		
RD, RDC	102 (46.3)	135 (61.2)
CRD, CRDC	130 (59.0)	175 (79.4)
<b>2500 Amperes</b>		
RD, RDC	135 (61.2)	182 (82.6)

**Note**

<sup>Ⓢ</sup> No four-pole for CRD and CRDC.

#### Motor Circuit Protectors

2



#### Contents

<i>Description</i>	<i>Page</i>
Product Overview . . . . .	<b>V4-T2-116</b>
Standards and Certifications . . . . .	<b>V4-T2-117</b>
Quick Reference . . . . .	<b>V4-T2-118</b>
G-Frame (15–100 Amperes) . . . . .	<b>V4-T2-121</b>
F-Frame (10–225 Amperes) . . . . .	<b>V4-T2-135</b>
J-Frame (70–250 Amperes) . . . . .	<b>V4-T2-153</b>
K-Frame (70–400 Amperes) . . . . .	<b>V4-T2-161</b>
L-Frame (125–600 Amperes) . . . . .	<b>V4-T2-185</b>
M-Frame (300–800 Amperes) . . . . .	<b>V4-T2-211</b>
N-Frame (400–1200 Amperes) . . . . .	<b>V4-T2-222</b>
R-Frame (800–2500 Amperes) . . . . .	<b>V4-T2-237</b>
Motor Circuit Protectors (MCP)	
Catalog Number Selection . . . . .	<b>V4-T2-257</b>
Product Selection . . . . .	<b>V4-T2-258</b>
Accessories . . . . .	<b>V4-T2-259</b>
Motor Protection Circuit Breakers (MPCB) . . . . .	<b>V4-T2-267</b>
Type ELC Current Limiter Attachment (Size 0–4) . . . . .	<b>V4-T2-269</b>
Current Limiting Circuit Breaker Module . . . . .	<b>V4-T2-270</b>
Internal Accessories . . . . .	<b>V4-T2-273</b>
External Accessories . . . . .	<b>V4-T2-304</b>

### Motor Circuit Protectors (MCP)

#### Product Description

Designated as Eaton’s Types GMCP and HMCP, the instantaneous-only motor circuit protector (MCP) is available in ratings from 3 A to 1200 A for motor starter sizes 0 through 8.

An innovative design of internal components allows higher MCP-starter combination interrupting ratings. The MCP is marked to permit proper electrical application within the assigned equipment ratings.

#### Standards and Certifications

The MCP is designed to comply with the applicable requirements of Underwriters Laboratories Standard UL 489, Canadian Standards Association Standard C22.2 No. 5.1, and International Electrotechnical Commission Recommendations IEC 157-1.

The MCP is a recognized component (UL File E7819) and complies with the applicable requirements of Underwriters Laboratories Standard UL 489. It is also designed to comply with the applicable requirements of Canadian Standards Association Standard C22.2 No. 5.1, International Electrotechnical Commission Recommendations IEC 157-1, and nameplates bear the CE marking.



**Note:** Interrupting ratings are dependent on starter it is used with.

### Catalog Number Selection

This information is presented only as an aid to understanding catalog numbers. It is not to be used to build catalog numbers for circuit breakers or trip units.

### Motor Circuit Protector

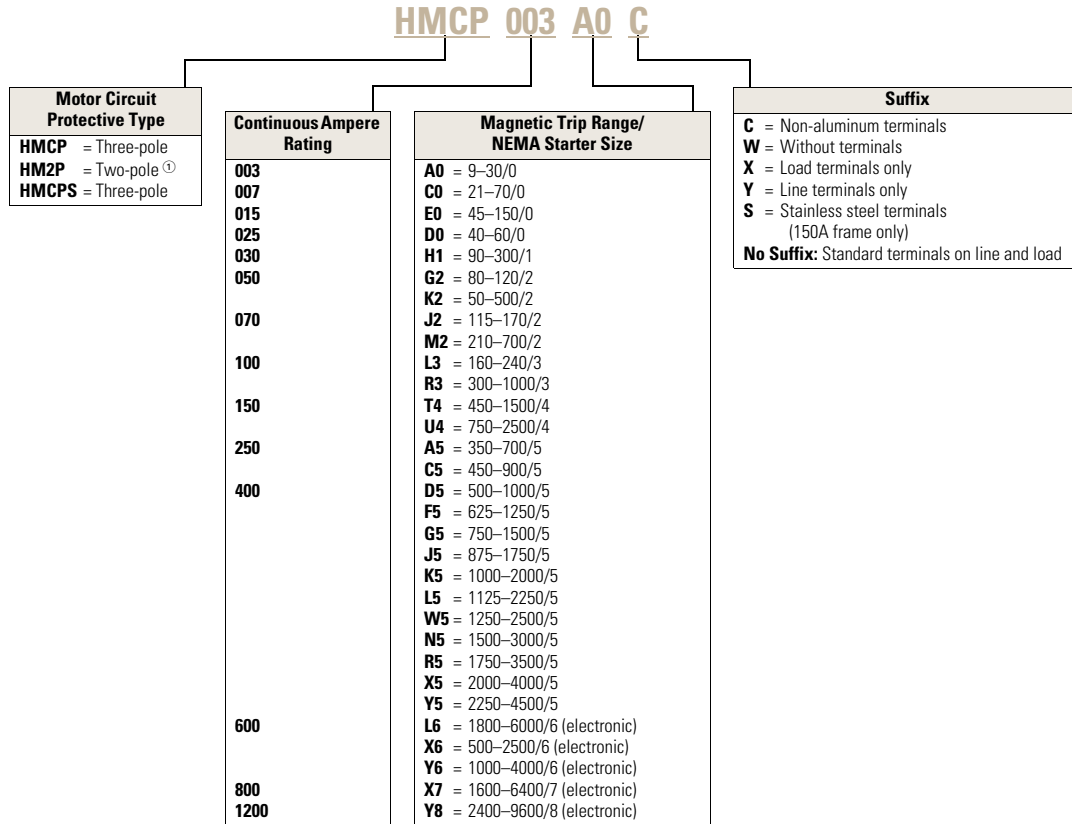

### Motor Circuit Protector

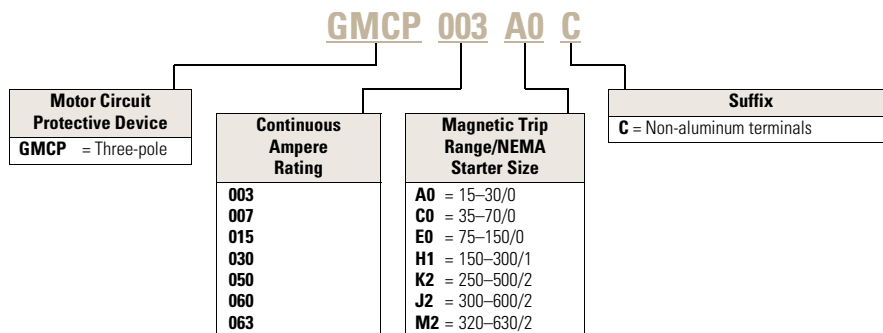

**Note**

① On J- and K-Frame HMCPs only.

## Product Selection

## G-Frame

2

## 480 Vac Maximum, 600Y/347 Vac

NEMA Starter Size	Continuous Amperes	Cam Setting	Motor Full Load Current Amperes (FLA) <sup>①</sup>	MCP Trip Setting	MCP Catalog Number
0	3	A	1.1–1.2	15	GMCP003A0C
		B	1.3–1.5	18	
		C	1.6–1.7	21	
		D	1.8–1.9	24	
		E	2.0–2.2	27	
		F	2.3–2.5	30	
0	7	A	2.6–3.1	35	GMCP007C0C
		B	3.2–3.6	42	
		C	3.7–3.9	49	
		D	4.3–4.7	56	
		E	4.8–5.2	63	
		F	5.3–5.7	70	
0	15	A	5.7–6.8	75	GMCP015E0C
		B	6.9–7.9	90	
		C	8.0–9.1	105	
		D	9.2–10.3	120	
		E	10.4–11.4	135	
		F	11.5–12.6	150	
1	30	A	11.5–13.7	150	GMCP030H1C
		B	13.8–16.0	180	
		C	16.1–18.3	210	
		D	18.4–20.6	240	
		E	20.7–22.9	270	
		F	23.0–25.2	300	
2	50	A	19.3–22.9	250	GMCP050K2C
		B	23.0–26.8	300	
		C	26.9–30.6	350	
		D	30.7–34.5	400	
		E	34.6–38.3	450	
		F	38.4–42.1	500	
3	60	A	23.1–27.5	300	GMCP060J2C
		B	27.7–32.2	360	
		C	32.3–36.7	420	
		D	36.9–41.4	480	
		E	41.5–46.0	540	
		F	46.2–50.5	600	
3	63	A	24.2–32.1	320	GMCP063M2C
		B	29.1–34.8	380	
		D	38.8–46.4	500	
		E	43.6–48.9	570	
		F	48.5–53.7	630	

## Notes

<sup>①</sup> Motor FLA ranges are typical. The corresponding trip setting is at 13 x the minimum FLA value shown. Where a 13 x setting is required for an intermediate FLA value, alternate Cam settings and/or MCP ratings should be used.

All GMCP 3–63A come with line and load steel body terminals for Cu only wire. Refer to **Page V4-T2-122** under Optional Terminal Types.

UL recognized and CSA approved.

## Accessories

### Modifications for GMCP

Internal accessories must be factory installed.

### Internal Accessories <sup>①</sup>

Type Accessory	Electrical Ratings			Contact Arrangement	Factory Suffix	Style Number
	Volts	Frequency	Amperes			
Shunt trip <sup>②</sup>	120	50/60 Hz	1.1	—	S5	1373D62G18
Shunt trip <sup>②</sup>	240	50/60 Hz	2.1	—	S6	1373D62G19
Auxiliary switch <sup>③</sup>	240	50/60 Hz	6.0	1A/1B	A3	1288C74G03
Auxiliary switch <sup>③</sup>	240	50/60 Hz	6.0	2A/2B	A6	1288C73G03
Alarm switch <sup>③</sup>	240	50/60 Hz	6.0	Make/Break	B3	1288C75G03
Auxiliary switch/alarm switch combination <sup>③</sup>	240	50/60 Hz	6.0	1A/1B Make/Break	B13	1288C76G09

### External Mounted Accessories



Description	Number Units in Package	Style Number
Lock dog (non-padlockable)	1	1294C01H01
Mounting hardware	1	624B375G23
DIN rail adapter <sup>④</sup>	10	1225C79G02

### Modifications for HMCP

See Internal Accessories starting on **Page V4-T2-273**.

### Handle Mechanisms for Series C Frames

#### Kits Only (Kit Includes Shaft, Mechanism and Handle)—GMCP-Frame

Description	Rating Type		GMCP-Frame Catalog Number
	NEMA	IP	
 S01 blue handle, 12-inch shaft	1/3R/12	54	GMHMVD12B / 68C6039G05
	4/4X	65	GMHMVD12BX / 68C6039G07
 S01 red handle, 12-inch shaft	1/3R/12	54	GMHMVD12R / 68C6039G06
	4/4X	65	GMHMVD12RX / 68C6039G08

### Direct (Close-Coupled) Handle Mechanisms

#### G Direct <sup>⑤</sup>

Frame	Black Handle		Yellow Handle	
	With Shroud	Without Shroud	With Shroud	Without Shroud
	Catalog Number	Catalog Number	Catalog Number	Catalog Number
GMCP	HRGMC1S	HRGMC10	HRGMC3S	HRGMC30

#### Notes

- ① Only one accessory may be installed in GMCP.
- ② LH only.
- ③ RH only.
- ④ For use with standard 35 mm DIN rail such as, 35 x 7.5 or 15 mm per DIN EN50022.
- ⑤ Suitable for use on two- or three-pole G-Frame.

No UVR available on GMCP.

# 2.3

## Molded Case Circuit Breakers

### Series C

#### F-Frame

2

#### 600 Vac Maximum, 250 Vdc Maximum

NEMA Starter Size	Cont. Amps	Cam Setting	Motor Full Load Current Amperes (FLA) <sup>①</sup>	MCP Trip Setting <sup>②</sup>	MCP Catalog Number
0	3	A	0.69–0.91	9	<b>HMCP003A0C</b>
		B	0.92–1.0	12	
		C	1.1–1.2	15	
		D	1.3–1.5	18	
		E	1.6–1.7	21	
		F	1.8–1.9	24	
		G	2.0–2.2	27	
		H	2.3–2.5	30	
0	7	A	1.5–2.0	21	<b>HMCP007C0C</b>
		B	2.1–2.5	28	
		C	2.6–3.1	35	
		D	3.2–3.6	42	
		E	3.7–3.9	49	
		F	4.3–4.7	56	
		G	4.8–5.2	63	
		H	5.3–5.7	70	
0	15	A	3.4–4.5	45	<b>HMCP015E0C</b>
		B	4.6–5.6	60	
		C	5.7–6.8	75	
		D	6.9–7.9	90	
		E	8.0–9.1	105	
		F	9.2–10.3	120	
		G	10.4–11.4	135	
		H	11.5–12.6	150	
1	30	A	6.9–9.1	90	<b>HMCP030H1C</b>
		B	9.2–11.4	120	
		C	11.5–13.7	150	
		D	13.8–16.0	180	
		E	16.1–18.3	210	
		F	18.4–20.6	240	
		G	20.7–22.9	270	
		H	23.0–25.2	300	
2	50	A	11.5–15.2	150	<b>HMCP050K2C</b>
		B	15.3–19.1	200	
		C	19.2–22.9	250	
		D	23.0–26.8	300	
		E	26.9–30.6	350	
		F	30.7–4.5	400	
		G	34.6–38.3	450	
		H	38.4–42.1	500	

#### 600 Vac Maximum, 250 Vdc Maximum, continued

NEMA Starter Size	Cont. Amps	Cam Setting	Motor Full Load Current Amperes (FLA) <sup>①</sup>	MCP Trip Setting <sup>②</sup>	MCP Catalog Number
2	70	A	16.1–21.4	210	<b>HMCP070M2C</b>
		B	21.5–26.8	280	
		C	26.9–32.2	350	
		D	32.3–37.5	420	
		E	37.6–42.9	490	
		F	43.0–48.3	560	
		G	48.4–53.7	630	
		H	53.8–59.1	700	
3	100	A	23.0–30.6	300	<b>HMCP100R3C</b>
		B	30.7–38.3	400	
		C	38.4–46.0	500	
		D	46.1–53.7	600	
		E	53.8–61.4	700	
		F	61.5–69.1	800	
		G	69.2–76.8	900	
		H	76.9–84.5	1000	
4	150	A	34.6–46.0	450	<b>HMCP150T4C</b>
		B	46.1–57.5	600	
		C	57.6–69.1	750	
		D	69.2–80.6	900	
		D	69.2–80.6	900	
		E	80.7–92.2	1050	
		F	92.3–103.7	1200	
		G	103.8–115.2	1350	
4	150	A	57.0–75.0	750	<b>HMCP150U4C</b>
		B	76.0–95.0	1000	
		C	96.0–114.0	1250	
		D	115.0–130.7	1500	
		E	③	1750	
		F	③	2000	
		G	③	2250	
		H	③	2500	

#### Notes

- ① Motor FLA ranges are typical. The corresponding trip setting is at 13 x the minimum FLA value shown. Where a 13 x setting is required for an intermediate FLA value, alternate Cam settings and/or MCP ratings should be used.
- ② For DC applications, actual trip levels are approximately 40% higher than values shown.
- ③ Settings above 130 amperes are for special applications. NEC Article 430.110(a) requires the ampere rating of the disconnecting means to be not less than 115% of the motor full load ampere rating.

HMCP 3–100 A come with line and load steel body terminals, 3T100FB. HMCP 150A come with line and load steel body terminals, 3T150FB.

**Special Low Magnetic Protection Application MCP****600 Vac Maximum, 250 Vdc Maximum**

<b>Cont. Amps</b>	<b>Cam Setting</b>	<b>MCP Trip Setting <sup>①</sup></b>	<b>MCP Catalog Number</b>
25	A	40	<b>HMCP025D0C</b>
	B	43	
	D	49	
	E	52	
	F	55	
	G	58	
	H	60	
	50	A	
B		87	
C		93	
D		98	
E		103	
F		109	
G		115	
H		120	
70	A	115	<b>HMCP070J2C</b>
	B	122	
	C	130	
	D	139	
	E	145	
	F	153	
	G	160	
	H	170	
100	A	160	<b>HMCP100L3C</b>
	B	174	
	C	185	
	D	196	
	E	207	
	F	218	
	G	229	
	H	240	

**Notes**

<sup>①</sup> For DC applications, actual trip levels are approximately 40% higher than values shown.

HMCP 25–100 A come with line and load steel body terminals, 3T100FB.

# 2.3

## Molded Case Circuit Breakers

### Series C

#### MCPs for Application with Motor Starters Equipped with Electronic Overload Relays

2

#### 600 Vac Maximum, 250 Vdc Maximum

NEMA Starter Size	Cont. Amps	Cam Setting	Motor Full Load Current Amperes (FLA) ①	MCP Trip Setting ②	MCP Catalog Number
0	3	A	0.69–0.91	9	<b>HMCP5003A0C</b>
		B	0.92–1.0	12	
		C	1.1–1.2	15	
		D	1.3–1.5	18	
		E	1.6–1.7	21	
		F	1.8–1.9	24	
		G	2.0–2.2	27	
		H	2.3–2.5	30	
0	7	A	1.5–2.0	21	<b>HMCP5007C0C</b>
		B	2.1–2.5	28	
		C	2.6–3.1	35	
		D	3.2–3.6	42	
		E	3.7–3.9	49	
		F	4.3–4.7	56	
		G	4.8–5.2	63	
		H	5.3–5.7	70	
0	15	A	3.4–4.5	45	<b>HMCP5015E0C</b>
		B	4.6–5.6	60	
		C	5.7–6.8	75	
		D	6.9–7.9	90	
		E	8.0–9.1	105	
		F	9.2–10.3	120	
		G	10.4–11.4	135	
		H	11.5–12.6	150	
1	30	A	6.9–9.1	90	<b>HMCP5030H1C</b>
		B	9.2–11.4	120	
		C	11.5–13.7	150	
		D	13.8–16.0	180	
		E	16.1–18.3	210	
		F	18.4–20.6	240	
		G	20.7–22.9	270	
		H	23.0–25.2	300	
2	50	A	11.5–15.2	150	<b>HMCP5050K2C</b>
		B	15.3–19.1	200	
		C	19.2–22.9	250	
		D	23.0–26.8	300	
		E	26.9–30.6	350	
		F	30.7–34.5	400	
		G	34.6–38.3	450	
		H	38.4–42.1	500	

#### 600 Vac Maximum, 250 Vdc Maximum, continued

NEMA Starter Size	Cont. Amps	Cam Setting	Motor Full Load Current Amperes (FLA) ①	MCP Trip Setting ②	MCP Catalog Number
3	100	A	23.0–30.6	300	<b>HMCP5100R3C</b>
		B	30.7–38.3	400	
		C	38.4–46.0	500	
		D	46.1–53.7	600	
		E	53.8–61.4	700	
		F	61.5–69.1	800	
		G	69.2–76.8	900	
		H	76.9–84.5	1000	
4	150	A	34.6–46.0	450	<b>HMCP5150T4C</b>
		B	46.1–57.5	600	
		C	57.6–69.1	750	
		D	69.2–80.6	900	
		E	80.7–92.2	1050	
		F	92.3–103.7	1200	
		G	103.8–115.2	1350	
		H	115.3–126.7	1500	
4	150	A	57.0–75.0	750	<b>HMCP5150U4C</b>
		B	76.0–95.0	1000	
		C	96.0–114.0	1250	
		D	115.0–130.7	1500	
		E	③	1750	
		F	③	2000	
		G	③	2250	
		H	③	2500	

#### Notes

- ① Motor FLA ranges are typical. The corresponding trip setting is at 13 x the minimum FLA value shown. Where a 13 x setting is required for an intermediate FLA value, alternate cam settings and/or MCP ratings should be used.
- ② For DC applications, actual trip levels are approximately 40% higher than values shown.
- ③ Settings above 130A are for special applications. NEC Article 430.110(a) requires the ampere rating of the disconnecting means to be not less than 115% of the motor full load ampere rating.

HMCP 25–100 A come with line and load steel body terminals, 3T100FB.

HMCP 3–100 A come with line and load steel body terminals, 3T100FB. HMCP 150A come with line and load steel body terminals, 3T150FB.

**J-Frame****600 Vac Maximum, 250 Vdc Maximum**

NEMA Starter Size	Cont. Amps	Cam Setting	Motor Full Load Current Amperes (FLA) <sup>①</sup>	MCP Trip Setting <sup>②</sup>	MCP Catalog Number <sup>③</sup>
4	250	A	27.0–30.7	350	<b>HMCP250A5C</b>
		B	30.8–33.8	400	
		C	33.9–36.9	440	
5	250	D	37.0–40.3	480	
		E	40.4–43.8	525	
		F	43.9–46.9	570	
		G	47.0–50.7	610	
		H	47.0–50.7	660	
		I	47.0–50.7	700	
5	250	A	34.7–38.8	450	<b>HMCP250C5C</b>
		B	38.9–43.4	505	
		C	43.5–47.6	565	
		D	47.7–52.2	620	
		E	52.3–56.5	680	
		F	56.6–60.7	735	
		G	60.8–64.9	790	
		H	65.0–69.2	845	
		I	69.3–73.5	900	
5	250	A	38.5–43.4	500	<b>HMCP250D5C</b>
		B	43.5–48.0	565	
		C	48.1–53.0	625	
		D	53.1–57.6	690	
		E	57.7–62.3	750	
		F	62.4–67.3	810	
		G	67.4–71.9	875	
		H	72.0–76.9	935	
		I	77.0–81.6	1000	
5	250	A	48.1–53.8	625	<b>HMCP250F5C</b>
		B	53.9–59.9	700	
		C	60.0–66.1	780	
		D	66.2–72.3	860	
		E	72.4–78.4	940	
		F	78.5–83.8	1020	
		G	83.9–89.9	1090	
		H	90.0–96.1	1170	
		I	96.2–102.0	1250	
5	250	A	57.7–64.6	750	<b>HMCP250G5C</b>
		B	64.7–71.9	840	
		C	72.0–79.2	935	
		D	79.3–86.5	1030	
		E	86.6–93.8	1125	
		F	93.9–101.1	1220	
		G	101.2–108.4	1315	
		H	108.5–115.3	1410	
		I	115.4–122.4	1500	

**600 Vac Maximum, 250 Vdc Maximum, continued**

NEMA Starter Size	Cont. Amps	Cam Setting	Motor Full Load Current Amperes (FLA) <sup>①</sup>	MCP Trip Setting <sup>②</sup>	MCP Catalog Number <sup>③</sup>
5	250	A	67.4–75.3	875	<b>HMCP250J5C</b>
		B	75.4–83.8	980	
		C	83.9–92.3	1090	
		D	92.4–100.7	1200	
		E	100.8–109.2	1310	
		F	109.3–117.6	1420	
		G	117.7–126.1	1530	
		H	126.2–134.6	1640	
		I	134.7–142.8	1750	
5	250	A	77.0–86.6	1000	<b>HMCP250K5C</b>
		B	86.6–96.1	1125	
		C	96.2–105.7	1250	
		D	105.8–115.3	1375	
		E	115.4–124.9	1500	
		F	125.0–134.6	1625	
		G	134.7–144.2	1750	
		H	144.3–153.8	1875	
		I	153.9–163.3	2000	
5	250	A	86.6–97.3	1125	<b>HMCP250L5C</b>
		B	97.4–108.4	1265	
		C	108.5–118.8	1410	
		D	118.9–129.9	1545	
		E	130.0–140.7	1690	
		F	140.8–151.5	1830	
		G	151.6–162.3	1970	
		H	162.4–173.0	2110	
		I	173.1–183.6	2250	
5	250	A	96.2–108.0	1250	<b>HMCP250W5C</b>
		B	108.1–119.9	1405	
		C	120.0–132.3	1560	
		D	132.4–144.2	1720	
		E	144.3–156.1	1875	
		F	156.2–168.0	2030	
		G	168.1–179.9	2185	
		H	180.0–192.3	2340	
		I	192.4–204.0	2500	

**Notes**

<sup>①</sup> Motor FLA ranges are typical. The corresponding trip setting is at 13 times the minimum FLA value shown. Where a 13 times setting is required for an intermediate FLA value, alternate cam settings and/or MCP ratings should be used.

<sup>②</sup> For DC applications, actual trip levels are approximately 40% higher than values shown.

<sup>③</sup> Three-pole catalog numbers shown. Two-pole catalog numbers begin with **HM2P** in place of **HMCP**.

All HMCP and HM2P 250A come with line and load steel body terminals, T250KB. (With suffix "C," without "C" comes with TA250KB.)

## K-Frame

2

## 600 Vac Maximum, 250 Vdc Maximum

NEMA Starter Size	Cont. Amps	Cam Setting	Motor Full Load Current Amperes (FLA) <sup>①</sup>	MCP Trip Setting <sup>②</sup>	MCP Catalog Number <sup>③</sup>
4	400	A	27.0–30.7	350	<b>HMCP400A5C</b>
		B	30.8–33.8	400	
		C	33.9–36.9	440	
5	400	D	37.0–40.3	480	<b>HMCP400A5C</b>
		E	40.4–43.8	525	
		F	43.9–46.9	570	
		G	47.0–50.7	610	
		H	50.8–53.8	660	
		I	53.9–57.2	700	
5	400	A	38.5–43.4	500	<b>HMCP400D5C</b>
		B	43.5–48.0	565	
		C	48.1–53.0	626	
		D	53.1–57.6	690	
		E	57.7–62.3	750	
		F	62.4–67.3	810	
		G	67.4–71.9	875	
		H	72.0–76.9	935	
		I	77.0–81.6	1000	
5	400	A	48.1–53.8	625	<b>HMCP400F5C</b>
		B	53.9–59.9	700	
		C	60.0–66.1	780	
		D	66.2–72.3	860	
		E	72.4–78.4	940	
		F	78.5–83.8	1020	
		G	83.9–89.9	1090	
		H	90.0–96.1	1170	
		I	96.2–102.0	1250	
5	400	A	57.7–64.6	750	<b>HMCP400G5C</b>
		B	64.7–71.9	840	
		C	72.0–79.2	935	
		D	79.3–86.5	1030	
		E	86.6–93.8	1125	
		F	93.9–101.1	1220	
		G	101.2–108.4	1315	
		H	108.5–115.3	1410	
		I	115.4–122.4	1500	
5	400	A	67.4–75.3	875	<b>HMCP400J5C</b>
		B	75.4–83.8	980	
		C	83.9–92.3	1090	
		D	92.4–100.7	1200	
		E	100.8–109.2	1310	
		F	109.3–117.6	1420	
		G	117.7–126.1	1530	
		H	126.2–134.6	1640	
		I	134.7–142.8	1750	

## 600 Vac Maximum, 250 Vdc Maximum, continued

NEMA Starter Size	Cont. Amps	Cam Setting	Motor Full Load Current Amperes (FLA) <sup>①</sup>	MCP Trip Setting <sup>②</sup>	MCP Catalog Number <sup>③</sup>	
5	400	A	77.0–86.5	1000	<b>HMCP400K5C</b>	
		B	86.6–96.1	1125		
		C	96.2–105.7	1250		
		D	105.8–115.3	1375		
		E	115.4–124.9	1500		
		F	125.0–134.6	1625		
5	400	G	134.7–144.2	1750	<b>HMCP400L5C</b>	
		H	144.3–153.8	1875		
		I	153.9–163.3	2000		
		A	86.6–97.3	1125		<b>HMCP400W5C</b>
		B	97.4–108.4	1265		
		C	108.5–118.8	1410		
		D	118.9–129.9	1545		
		E	130.0–140.7	1690		
		F	140.8–151.5	1830		
G	151.6–162.3	1970				
H	162.4–173.0	2110				
I	173.1–183.6	2250				
5	400	A	96.2–108.0	1250	<b>HMCP400N5C</b>	
		B	108.1–119.9	1405		
		C	120.0–132.3	1560		
		D	132.4–144.2	1720		
		E	144.3–156.1	1875		
		F	156.2–168.0	2030		
		G	168.1–179.9	2185		
		H	180.0–192.3	2340		
		I	192.4–204.0	2500		
5	400	A	115.4–129.9	1500	<b>HMCP400O5C</b>	
		B	130.0–144.2	1690		
		C	144.3–158.4	1875		
		D	158.5–173.0	2060		
		E	173.1–187.6	2250		
		F	187.7–201.9	2440		
		G	202.0–216.1	2625		
		H	216.2–230.7	2810		
		I	230.8–244.9	3000		

**Notes**

- ① Motor FLA ranges are typical. The corresponding trip setting is at 13 x the minimum FLA value shown. Where a 13 x setting is required for an intermediate FLA value, alternate cam settings and/or MCP ratings should be used.
- ② For DC applications, actual trip levels are approximately 40% higher than values shown.
- ③ Three-pole catalog numbers shown. Two-pole catalog numbers begin with **HM2P** in place of **HMCP**.

All HMCP and HM2P 400 A come with aluminum body terminals, 3TA400K. Catalog numbers with suffix "C" as shown above come with copper body terminals 3T400K.

## 600 Vac Maximum, 250 Vdc Maximum, continued

NEMA Starter Size	Cont. Amps	Cam Setting	Motor Full Load Current Amperes (FLA) ①	MCP Trip Setting ②	MCP Catalog Number ③
5	400	A	134.7–151.5	1750	<b>HMCP400R5C</b>
		B	151.6–168.4	1970	
		C	168.5–185.3	2190	
		D	185.4–201.9	2410	
		E	202.0–218.8	2625	
		F	218.9–235.7	2845	
		G	235.8–252.6	3065	
		H	252.7–269.2	3285	
		I	269.3–285.7	3500	
5	400	A	153.9–173.0	2000	<b>HMCP400X5C</b>
		B	173.1–192.3	2250	
		C	192.4–211.5	2500	
		D	211.6–230.7	2750	
		E	230.8–249.9	3000	
		F	250.0–269.2	3250	
		G	269.3–288.4	3500	
		H	288.5–307.6	3750	
		I	307.7–326.9	4000	
5	400	A	173.1–194.5	2250	<b>HMCP400Y5C</b>
		B	194.6–216.1	2530	
		C	216.2–237.6	2810	
		D	237.7–259.5	3090	
		E	259.6–281.1	3375	
		F	281.2–302.6	3655	
		G	302.7–324.1	3935	
		H	324.2–346.1	4215	
		I	346.2–368.1	4500	

## L-Frame

## 600 Vac Maximum ④

NEMA Starter Size	Cont. Amps	Cam Setting	Motor Full Load Current Amperes (FLA) ①	MCP Trip Setting	MCP Catalog Number
6	600	A	138.5–184.5	1800	<b>HMCP600L6W</b>
		B	184.6–230.7	2400	
		C	230.8–276.8	3000	
		D	276.9–323.0	3600	
		E	323.1–369.1	4200	
		F	369.2–415.3	4800	
		G	415.4–461.4	5400	
		H	461.5–507.7	6000	
6	600	A	38.5–46.1	500	<b>HMCP600X6W</b>
		B	46.2–61.4	600	
		C	61.5–76.8	800	
		D	76.9–96.1	1000	
		E	96.2–115.3	1250	
		F	115.4–153.7	1500	
		G	153.8–192.2	2000	
		H	192.3–230.7	2500	
6	600	A	76.9–96.1	1000	<b>HMCP600Y6W</b>
		B	96.2–115.3	1250	
		C	115.4–153.7	1500	
		D	153.8–192.2	2000	
		E	192.3–230.7	2500	
		F	230.8–269.1	3000	
		G	269.2–307.6	3500	
		H	307.7–346.1	4000	

**Notes**

① Motor FLA ranges are typical. The corresponding trip setting is at 13 x the minimum FLA value shown. Where a 13 x setting is required for an intermediate FLA value, alternate cam settings and/or MCP ratings should be used.

② For DC applications, actual trip levels are approximately 40% higher than values shown.

③ Three-pole catalog numbers shown. Two-pole catalog numbers begin with **HM2P** in place of **HMCP**.

④ Equipped with electronic trip device.

All HMCP and HM2P 400 A come with aluminum body terminals, 3TA400K. Catalog numbers with suffix "C" as shown above come with copper body terminals 3T400K.

All HMCP 600 A come without terminals. For terminals, see **Page V4-T2-217**.

**N-Frame**

2

**600 Vac Maximum** <sup>①</sup>

<b>NEMA Starter Size</b>	<b>Cont. Amps</b>	<b>Cam Setting</b>	<b>Motor Full Load Current Amperes (FLA)</b> <sup>②</sup>	<b>MCP Trip Setting</b>	<b>MCP Catalog Number</b>
7	800	A	123.1–184.5	1600	<b>HMCP800X7W</b>
		B	184.6–246.1	2400	
		C	246.2–307.6	3200	
		D	307.7–369.1	4000	
		E	369.2–430.7	4800	
		F	430.8–492.2	5600	
		G	492.3–553.7	6400	
8	1200	A	184.6–276.8	2400	<b>HMCP12Y8W</b>
		B	276.9–369.1	3600	
		C	369.2–461.4	4800	
		D	461.5–553.7	6000	
		E	553.8–646.1	7200	
		F	646.2–738.4	8400	
		G	738.5–830.7	9600	

**Notes**

- <sup>①</sup> Equipped with electronic trip device.
- <sup>②</sup> Motor FLA ranges are typical. The corresponding trip setting is at 13X the minimum FLA value shown. Where a 13X setting is required for an intermediate FLA value, alternate cam settings and/or MCP ratings should be used.

## Motor Protection Circuit Breakers



## Contents

## Description

	<i>Page</i>
Product Overview . . . . .	<b>V4-T2-116</b>
Standards and Certifications . . . . .	<b>V4-T2-117</b>
Quick Reference . . . . .	<b>V4-T2-118</b>
G-Frame (15–100 Amperes) . . . . .	<b>V4-T2-121</b>
F-Frame (10–225 Amperes) . . . . .	<b>V4-T2-135</b>
J-Frame (70–250 Amperes) . . . . .	<b>V4-T2-153</b>
K-Frame (70–400 Amperes) . . . . .	<b>V4-T2-161</b>
L-Frame (125–600 Amperes) . . . . .	<b>V4-T2-185</b>
M-Frame (300–800 Amperes) . . . . .	<b>V4-T2-211</b>
N-Frame (400–1200 Amperes) . . . . .	<b>V4-T2-222</b>
R-Frame (800–2500 Amperes) . . . . .	<b>V4-T2-237</b>
Motor Circuit Protectors (MCP) . . . . .	<b>V4-T2-256</b>
Motor Protection Circuit Breakers (MPCB)	
Product Selection . . . . .	<b>V4-T2-268</b>
Technical Data and Specifications . . . . .	<b>V4-T2-268</b>
Type ELC Current Limiter Attachment (Size 0–4) . . . . .	<b>V4-T2-269</b>
Current Limiting Circuit Breaker Module . . . . .	<b>V4-T2-270</b>
Internal Accessories . . . . .	<b>V4-T2-273</b>
External Accessories . . . . .	<b>V4-T2-304</b>

## Motor Protection Circuit Breakers (MPCB)

## Product Description

Motor protection circuit breakers (MPCBs) provide UL 489 branch circuit protection, UL 508 and CSA C22.2 No. 14 motor protection, and meet IEC 60947-2 and 50947-4 requirements. Typical branch motor loads are protected by three-component starters, consisting of breaker, contactor and overload relay, or fuse, contactor and overload relay. The MPCB application-specific protection eliminates the need for motor overload relay found in the traditional three-component starter assembly. The branch motor load protection is simplified to an MPCB and contactor, reducing both space requirements and heat generation in customer panels. Protection is provided by application-specific electronic trip units.

The electronic trip unit provides typical motor overload relay functionality and short-circuit protection against potential phase-to-phase or phase-to-ground faults.

- Disconnecting means
- Branch circuit short-circuit protection
- Overload protection
  - Class 5, 10, 15 and 20
- Phase unbalance protection
  - FDMP breaker trips when there is a 40% difference between any phase compared to the calculated three-phase average

- Phase loss protection
  - Active when the maximum phase current is greater than 50% of FLA setting
  - Breaker will trip when minimum phase current is 25% or less than the maximum phase current
  - Time delay of 1 or 2 seconds before breaker trips
- Thermal memory to prevent immediate restart after overload trip to allow motor to cool down

The MPCB is based on the Series C F-Frame. Accessories for standard Series C breakers apply to the MPCB. Unlike Motor Circuit Protectors (MCPs), MPCBs are UL 489 listed with 35 kA and 65 kA interruption ratings.

## Product Selection

2

## FDMP and HFDMP

Continuous Amperes	35 kA Without Phase Unbalance, Class 10 Motor Protection Only	35 kA With Phase Unbalance and Adjustable Motor Class Protection	65 kA Without Phase Unbalance, Class 10 Motor Protection Only	65 kA With Phase Unbalance and Adjustable Motor Class Protection
80	FDMP3080L	FDMP3080JL	HFDMP3080L	HFDMP3080JL
100	FDMP3100L	FDMP3100JL	HFDMP3100L	HFDMP3100JL
160	FDMP3160L	FDMP3160JL	HFDMP3160L	HFDMP3160JL
205	FDMP3205L	FDMP3205JL	HFDMP3205L	HFDMP3205JL

## FLA Ie Dial Setting

Continuous Amperes	A	B	C	D	E	F	G	H
80	40	50	60	70	80	—	—	—
100	80	—	90	—	100	—	—	—
160	100	115	130	145	160	—	—	—
205	160	170	180	195	205	—	—	—

## Technical Data and Specifications

## Specifications

Feature	FDMP	HFDMP
Interruption rating at 240 V	65 kA	100 kA
Interruption rating at 480 V	35 kA	65 kA
Interruption rating at 600 V	18 kA	25 kA
Icu/lcs at 240 V	65 kA/33 kA ①	100 kA/50 kA ①
Icu/lcs at 415 V	35 kA/18 kA ①	65 kA/33 kA ①
100% rated	No	No
FLA range (A)	40–205	40–205
Motor class protection	5, 10, 15, 20	5, 10, 15, 20
Phase unbalance protection (current)—active for phase current >0.5 FLA setting	□40% delta (single-phase); (three-phase avg.) for 5 seconds	□40% delta (single-phase); (three-phase avg.) for 5 seconds
Phase loss protection (current)—active for phase current >0.5 FLA setting	Min. phase □0.25 max. phase for 1 second	Min. phase □0.25 max. phase for 1 second
Thermal memory protection	Yes	Yes
High load indicator	—	—
Pre-detection relays	—	—
Internal accessories	Factory installed Aux. alarm, shunt trip, UVR	Factory installed Aux. alarm, shunt trip, UVR

## Notes

① IEC ratings available only on FWMP and HFWMP.

For additional breaker solutions, see **Page V4-T2-89**.

Type ELC Current Limiter Attachment



**Contents**

<i>Description</i>	<i>Page</i>
Product Overview . . . . .	V4-T2-116
Standards and Certifications . . . . .	V4-T2-117
Quick Reference . . . . .	V4-T2-118
G-Frame (15–100 Amperes) . . . . .	V4-T2-121
F-Frame (10–225 Amperes) . . . . .	V4-T2-135
J-Frame (70–250 Amperes) . . . . .	V4-T2-153
K-Frame (70–400 Amperes) . . . . .	V4-T2-161
L-Frame (125–600 Amperes) . . . . .	V4-T2-185
M-Frame (300–800 Amperes) . . . . .	V4-T2-211
N-Frame (400–1200 Amperes) . . . . .	V4-T2-222
R-Frame (800–2500 Amperes) . . . . .	V4-T2-237
Motor Circuit Protectors (MCP) . . . . .	V4-T2-256
Motor Protection Circuit Breakers (MPCB) . . . . .	V4-T2-267
Type ELC Current Limiter Attachment (Size 0–4) . . . . .	V4-T2-270
Current Limiting Circuit Breaker Module . . . . .	V4-T2-273
Internal Accessories . . . . .	V4-T2-273
External Accessories . . . . .	V4-T2-304

**Type ELC Current Limiter Attachment (Size 0–4)**

**Product Description**

Eaton’s Type ELC current limiter attachment for the MCP is designed to provide increased interrupting capacity. The combination may be used for the application up to 200,000 A symmetrical at 600 Vac, making the MCP suitable for use in network distribution systems or other applications where unusually high fault currents are available. The current limiter connects to the load end of the MCP and is provided with terminals suitable for copper or aluminum conductors. (See table at right.)

Limiters are coordinated with the MCP so that normal fault currents are interrupted automatically by the MCP without any damage to the limiter. Only the rare very high fault is opened by the limiter. Faults that are interrupted by the limiter also magnetically trip the MCP, opening all three poles, preventing single-phase operation.

Each of the three poles of the Type ELC limiter is equipped with an indicator that extends when a fault is interrupted by the limiter.

**Product Selection**

**Type ELC Current Limiter Attachment**



MCP Rating (Amperes)	Catalog Number
3	ELC3003R
7	ELC3007R
15	ELC3015R
30	ELC3030R
50	ELC3050R
100	ELC3100R
150	ELC3150R

**Technical Data and Specifications**

**Type ELC Current Limiter Terminal Wire Sizes** ①

Type ELC Current Limiter Maximum Amperes	Wire Range AWG	Metric (mm <sup>2</sup> )
<b>Standard Aluminum Terminals</b>		
50	14–2	2.5–35
100	1–4/0	50–95
150	1–4/0	50–95
<b>Non-Standard Terminals (Steel)</b>		
50	14–2 ②	2.5–35
100	—	—
150	—	—

**Notes**

- ① Terminal wire connectors are UL listed for standard stranded wire sizes as defined in UL 486A or UL 486B.
  - ② Optional on special order for copper cable only.
- All HMCP 800 A and 1200 A come without terminals. For terminals, see **Page V4-T2-217**.

## Current Limiting Circuit Breaker Module

2



## Contents

<i>Description</i>	<i>Page</i>
Product Overview . . . . .	V4-T2-116
Standards and Certifications . . . . .	V4-T2-117
Quick Reference . . . . .	V4-T2-118
G-Frame (15–100 Amperes) . . . . .	V4-T2-121
F-Frame (10–225 Amperes) . . . . .	V4-T2-135
J-Frame (70–250 Amperes) . . . . .	V4-T2-153
K-Frame (70–400 Amperes) . . . . .	V4-T2-161
L-Frame (125–600 Amperes) . . . . .	V4-T2-185
M-Frame (300–800 Amperes) . . . . .	V4-T2-211
N-Frame (400–1200 Amperes) . . . . .	V4-T2-222
R-Frame (800–2500 Amperes) . . . . .	V4-T2-237
Motor Circuit Protectors (MCP) . . . . .	V4-T2-256
Motor Protection Circuit Breakers (MPCB) . . . . .	V4-T2-267
Type ELC Current Limiter Attachment (Size 0–4) . . . . .	V4-T2-269
Current Limiting Circuit Breaker Module	
Product Selection . . . . .	V4-T2-271
Technical Data and Specifications . . . . .	V4-T2-272
Dimensions and Weights . . . . .	V4-T2-272
Internal Accessories . . . . .	V4-T2-273
External Accessories . . . . .	V4-T2-304

## Current Limiting Circuit Breaker Module

## Product Overview

Power demand continues to grow in new and existing facilities. To meet increased demand, larger utility supplies, spot networks and large facility transformers are installed. The increased capacity of the electrical source results in increased fault currents in excess of 100 kA short-circuit protection. Eaton manufactures non-fused current limiting modules with interrupting capacities up to 200 kA at 600 Vac. Unlike fused current limiters with a one-time use, a current limiter module provides an automatic reset of the module after a short-circuit event. Resetting the molded-case circuit breaker is the only action required to restore critical power to the system; there is no time wasted with sourcing the correct replacement fuses or module to bring the system back online.

## Product Description

The current limiting breaker modules use a unique contact design to enhance the system protection similar to that of the circuit breaker. When high short-circuit current is flowing through the contacts of these modules, the design results in very high interrupting capacities and improved current limiting characteristics.

## Application Description

High-performance breakers are most commonly applied when very high fault levels are available and with applications where the current limiting capability is used upstream of the final load to limit current. Typical loads include lighting, power distribution, and motor control applications.

## Features and Benefits

Superior system protection:

- Auto reset improves system uptime and eliminates the need for finding replacement parts
- No fuses to replace, reducing the overall cost of ownership and the waste created by fuses
- Overloads, by using inverse time current tripping characteristics of the molded-case circuit breaker
- Low-level short circuits, by using instantaneous and/or short-time delay tripping characteristics of the molded-case circuit breaker
- High-level short circuits, by using ultra-high-speed, blow-apart contacts of the current limiting module in series with the circuit breaker contacts
- Let-through currents, by improved opening speed of the contacts, the resultant rapid rise of arc voltage introduces impedance into the system

## Standards and Certifications

- UL 489
- CSA C22.2



## Product Selection

## Series C High Performance Ratings

Type	Product	Amperes	480 Vac (UL)	600 Vac (UL)
FDC 3P thermal-magnetic	Breaker only	15–225	100	35
	With limiter	40–200	200	200

## FD Frame

FD IC Rating—200 kAIC at 600 Vac <sup>①</sup>

Ampere Rating	Breaker with Line Side Mounted Current Limiter <sup>②</sup>	Breaker with Load Side Mounted Current Limiter <sup>③</sup>
<b>Thermal-Magnetic</b>		
40	FDC3040Q01	FDC3040YQ02
45	FDC3045Q01	FDC3045YQ02
50	FDC3050Q01	FDC3050YQ02
60	FDC3060Q01	FDC3060YQ02
70	FDC3070Q01	FDC3070YQ02
80	FDC3080Q01	FDC3080YQ02
90	FDC3090Q01	FDC3090YQ02
100	FDC3100Q01	FDC3100YQ02
110	FDC3110Q01	FDC3110YQ02
125	FDC3125Q01	FDC3125YQ02
150	FDC3150Q01	FDC3150YQ02
175	FDC3175Q01	FDC3175YQ02
200	FDC3200Q01	FDC3200YQ02

## Limiter Terminals

Maximum Breaker Amperes	Terminal Body Material	Wire Type	Metric Wire Range mm <sup>2</sup>	AWG Wire Range/ Number of Conductors	Catalog Number
<b>Standard Pressure Type Terminals</b>					
250	Aluminum	Cu/Al	10–185	#8–350 (1)	TA250FJ <sup>④</sup>

## Breaker Load Terminals (For Line Mounted Limiters Only)

Maximum Breaker Amperes	Terminal Body Material	Wire Type	AWG Wire Range	Metric Wire Range mm <sup>2</sup>	Package of Three Terminals Catalog Number
<b>Standard Pressure Type Terminals</b>					
100	Steel	Cu/Al	14–1/0	2.5–50	3T100FB
225	Aluminum	Cu/Al	4–4/0	25–95	3TA225FD

## Notes

- <sup>①</sup> Line and load terminal included.  
<sup>②</sup> Two interphase barriers provided, mounted on line end of limiter, catalog number **FJ1PBK**.  
<sup>③</sup> Four interphase barriers provided, (2) line end of breaker, (2) load end of limiter.  
<sup>④</sup> Load side breaker terminations included for units configured with line mounted limiters.

### Technical Data and Specifications

2

#### UL 489 Current Limiting Data

Frame	Circuit	I <sub>p</sub> (kA)	I <sup>2</sup> T (10 <sup>6</sup> A <sup>2</sup> S)
LDC	240 V/200 kA	64.80	6.80
LDC	480 V/100 kA	66.90	9.33
LDC	600 V/50 kA	54.30	8.92

### Dimensions and Weights

Approximate Dimensions in Inches (mm)

#### Assembled Breaker and Current Limiting Module

Frame	Height	Width	Depth	Weight in lbs (kg)
FD + limiter	12.06 (306.3)	4.13 (104.9)	3.39 (86.1)	8.50 (3.86)

#### FD-Frame With Current Limiter Module

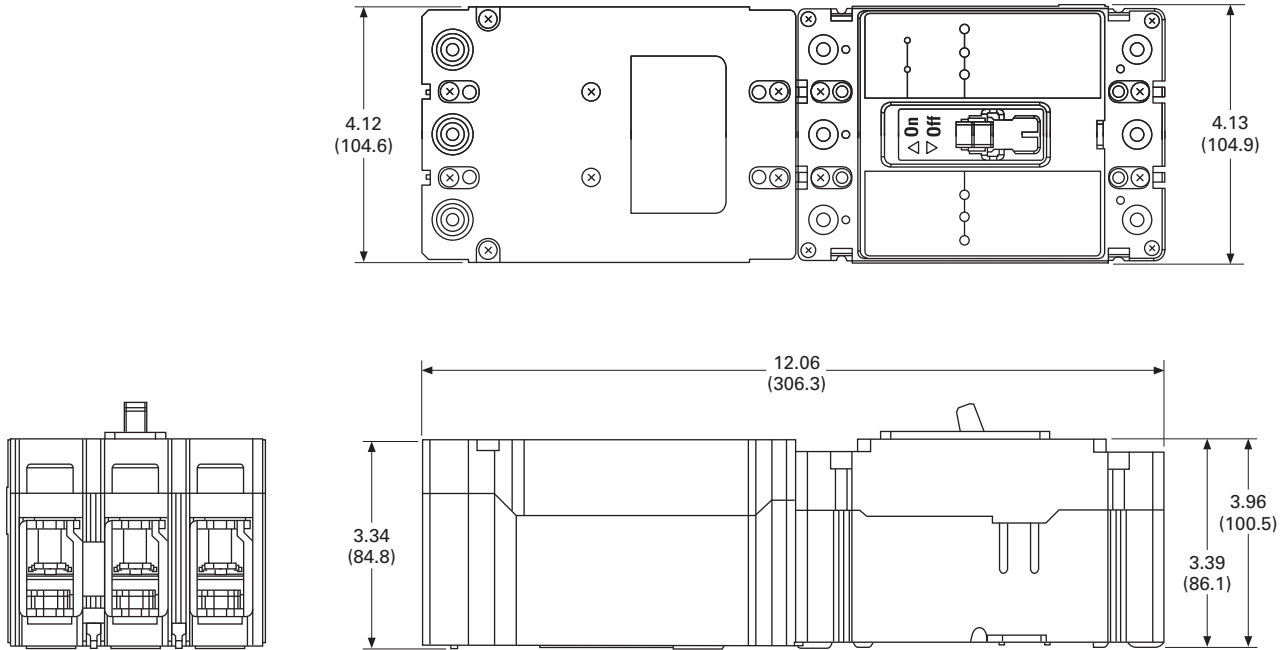

## Series C Internal Accessories

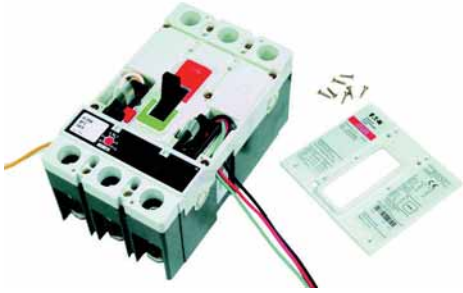

## Contents

<i>Description</i>	<i>Page</i>
Product Overview . . . . .	V4-T2-116
Standards and Certifications . . . . .	V4-T2-117
Quick Reference . . . . .	V4-T2-118
G-Frame (15–100 Amperes) . . . . .	V4-T2-121
F-Frame (10–225 Amperes) . . . . .	V4-T2-135
J-Frame (70–250 Amperes) . . . . .	V4-T2-153
K-Frame (70–400 Amperes) . . . . .	V4-T2-161
L-Frame (125–600 Amperes) . . . . .	V4-T2-185
M-Frame (300–800 Amperes) . . . . .	V4-T2-211
N-Frame (400–1200 Amperes) . . . . .	V4-T2-222
R-Frame (800–2500 Amperes) . . . . .	V4-T2-237
Motor Circuit Protectors (MCP) . . . . .	V4-T2-256
Motor Protection Circuit Breakers (MPCB) . . . . .	V4-T2-267
Type ELC Current Limiter Attachment (Size 0–4) . . . . .	V4-T2-269
Current Limiting Circuit Breaker Module . . . . .	V4-T2-270
Internal Accessories	
Product Selection . . . . .	V4-T2-275
Technical Data and Specifications . . . . .	V4-T2-294
External Accessories . . . . .	V4-T2-304

## Internal Accessories

## Product Overview

**Alarm Switch**

For remote indication of automatic trip operation. Does not function with manual switching; however, it will operate when either a shunt trip or undervoltage release is operated. A “make” contact closes and a “break” contact opens when the alarm/lockout switch operates. The switch automatically resets when the circuit breaker is reset.

**Auxiliary Switch**

The auxiliary switch provides circuit breaker contact status information by monitoring the position of the molded cross bar that contains the moving contact arms. The auxiliary switch is used for remote indication and interlock system verification, and consists of one or two SPDT switches housed in a plug-in module. Each SPDT switch has one “a” and one “b” contact. When the circuit breaker contacts are open, the “a” contact is open and the “b” contact is closed.

**Auxiliary Switch and Alarm Switch Combination**

Each catalog number listed in tables on **Pages V4-T2-278** and **V4-T2-279** includes one auxiliary switch and one alarm switch. In an auxiliary switch ASL switch combination, the auxiliary switch is always mounted on the side of the plug-in module next to the center pole of the circuit breaker.

**Shunt Trip**

The shunt trip provides remote controlled tripping of the circuit breaker. The shunt trip consists of an intermittent rated solenoid with a tripping plunger and a cutoff switch assembled to a plug-in module. When required for ground fault protection applications, certain AC rated shunt trips, as noted in the electrical rating table, are suitable for operation at 55 percent of rated voltage.

Select shunt trip catalog number for the voltage within the indicated voltage range. Shunt trip coils are designed to be applied at specific AC or DC voltages within the voltage range shown. Electrical ratings are also shown on applicable circuit breaker accessory nameplates.

**Low Energy Shunt Trip**

Low energy shunt trip devices are designed to operate from low energy output signals from dedicated current sensors typically applied in ground fault protection schemes. However, with a proper control voltage source, they may be applied in place of conventional trip devices for special applications. Flux paths surrounding permanent magnets used in the shunt trip assembly hold a charged spring poised in readiness to operate the circuit breaker trip mechanism.

When a 100 microfarad capacitor charged to 28 Vdc is discharged through the shunt trip coil, the resultant flux opposes the permanent magnet flux field, which releases the stored energy in the spring to trip the circuit breaker. As the circuit breaker resets, the shunt trip reset arm is actuated by the circuit breaker handle, resetting the shunt trip. The plug-in module is mounted in retaining slots in the top of the trip unit. Coil is intermittent-rated only. Cutoff provisions required in control circuit.

**Undervoltage Release Mechanism**

The undervoltage release mechanism monitors a voltage (typically a line voltage) and trips the circuit breaker when the voltage falls to between 70 and 35 percent of the solenoid coil rating.

The undervoltage release mechanism consists of a continuous rated solenoid with a plunger and tripping lever mounted in a plug-in module. The tab on the tripping lever resets the undervoltage release mechanism when normal voltage has been restored and the circuit breaker handle is moved to the reset (or OFF) position. With less than pickup voltage applied to the undervoltage release mechanism, the circuit breaker contacts will not touch when a closing operation is attempted.

**Note:** Undervoltage release mechanism accessories are not designed for, and should not be used as, circuit interlocks.

**Accessory Terminal Block (R-Frame)**

(For fixed-mounted configuration.)

Internal accessory wiring leads are normally supplied with pigtail leads (18 AWG) that exit from the right side of the circuit breaker. Where specified, fixed-mounted accessory terminal blocks are available. A maximum of one 24-point terminal block can be installed on the right side of the circuit breaker for the internal accessories.

For convenience in determining the appropriate number of terminal block points required, refer to **Page V4-T2-274**.

**PowerNet and Zone Interlock Kits (OPTIM 550 only) K-, L- and N-Frames**

Eaton's PowerNet Communications Kit can be ordered to add PowerNet communications to an existing OPTIM 550 breaker in the field. An 18-inch (457.2 mm) wiring pigtail is routed to the rear of the breaker: two wires for PowerNet and two wires for 24 Vdc (45 mA load). It is recommended that the power supply be an "isolated high quality" unit.

## Product Selection

## Alarm Switch

## Alarm Switch

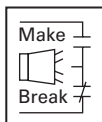

## G-Frame Alarm Switch (RH Only) ①

Electrical Ratings			Contact Arrangement	Factory Suffix	Catalog Number ②③④
Volts	Frequency	Amperes			
<b>Alarm Switch</b>					
240	50/60 Hz	6	1 Make/1 Break	<b>B3</b>	<b>1288C75G03</b>
<b>Alarm Switch Auxiliary Switches Combination</b>					
240	50/60 Hz	6	1 Make/1 Break and 1A/1B	<b>B13</b>	<b>1288C76G09</b>

## F-Frame Alarm Switch ①

Number of Contacts (Make and Break)	Mounting Location (Pole)	Factory Mounted Connection Type and Location			Factory Installation Kit ⑤		
		18-Inch (457.2 mm) Pigtail Leads			Terminal Block Same Side	Pigtail Leads	Terminal Block
		Same Side Suffix Number	Rear ⑥ Suffix Number	Opposite Side Suffix Number			
1	Left ⑦	<b>B01</b>	<b>B02</b>	<b>B03</b>	<b>B04</b>	<b>A1L1LPK</b>	<b>A1L1LTK</b>
	Right	<b>B05</b>	<b>B06</b>	<b>B07</b>	<b>B08</b>	<b>A1L1RPK</b>	<b>A1L1RTK</b>
2	Left ⑦	<b>B09</b>	<b>B10</b>	—	<b>B11</b>	<b>A2L1LPK</b>	<b>A2L1LTK</b>
	Right	<b>B12</b>	<b>B13</b>	—	<b>B14</b>	<b>A2L1RPK</b>	<b>A2L1RTK</b>
1	Single-pole	<b>B15</b> ⑧	—	—	—	—	—

## F-Frame HMCP Alarm Switch ①

Number of Contacts (Make and Break)	Mounting Location (Pole)	Factory Mounted Connection Type and Location			Factory Installation Kit ⑤		
		18-Inch (457.2 mm) Pigtail Leads			Terminal Block Same Side	Pigtail Leads	Terminal Block
		Same Side Suffix Number	Rear ⑥ Suffix Number	Opposite Side Suffix Number			
1	Left ⑦	<b>B01</b>	<b>B02</b>	<b>B03</b>	<b>B04</b>	<b>MA1L1LPK</b>	<b>MA1L1LTK</b>
	Right	<b>B05</b>	<b>B06</b>	<b>B07</b>	<b>B08</b>	<b>MA1L1RPK</b>	<b>MA1L1RTK</b>
2	Left ⑦	<b>B09</b>	<b>B10</b>	—	<b>B11</b>	<b>MA2L1LPK</b>	<b>MA2L1LTK</b>
	Right	<b>B12</b>	<b>B13</b>	—	<b>B14</b>	<b>MA2L1RPK</b>	<b>MA2L1RTK</b>

## J-Frame and HMCP (J) Alarm Switch

Number of Contacts (Make and Break)	Mounting Location (Pole)	Factory Mounted Connection Type and Location			Field Mounted Field Installation Kits ⑨		
		18-Inch (457.2 mm) Pigtail Leads			Terminal Block Same Side	Pigtail Leads	Terminal Block
		Same Side Suffix Number	Rear ⑦ Suffix Number	Opposite Side Suffix Number			
1	Left ⑧	<b>B01</b>	<b>B02</b>	<b>B03</b>	<b>B04</b>	<b>A1L2LPK</b>	<b>A1L2LTK</b>
	Right	<b>B05</b>	<b>B06</b>	<b>B07</b>	<b>B08</b>	<b>A1L2RPK</b>	<b>A1L2RTK</b> ⑨

## Notes

- ① F-Frame circuit breakers are factory sealed. Underwriters Laboratories requires that internal accessories be installed at the factory. Internal accessories are UL listed for factory installation under E7819. Where local codes and standards permit and UL listing is not required, internal accessories can be field installed; however, this is not recommended for FDE breakers. Accessory installation should be done before the circuit breaker is mounted and connected.
- ② Includes 24-inch (609.6 mm) external pigtail leads, 18 AWG (16–0.010).
- ③ A maximum of two internal accessories may be mounted in a three-pole circuit breaker.
- ④ Suitable for mounting in right pole only of two- or three-pole breaker.
- ⑤ Not listed with Underwriters Laboratories; for field installation.
- ⑥ Standard pigtail lead exit location.
- ⑦ Standard mounting location.
- ⑧ Factory installation only. Leads exit load end of circuit breaker.
- ⑨ Listed with Underwriters Laboratories; for field installation on interchangeable trip unit breakers under E64983.
- ⑩ Standard mounting location—leads exit rear of breaker.

## K-Frame and HMCP (K) Alarm Switch

Number of Sets of Contacts (1M and 1B)	Mounting Location (Pole)	Factory Mounted Connection Type and Location 18-Inch (457.2 mm) Pigtail Leads			Terminal Block Same Side Suffix Number	Field Mounted Field Installation Kits <sup>①</sup>	
		Same Side Suffix Number	Rear <sup>②</sup> Suffix Number	Opposite Side Suffix Number		Pigtail Leads Catalog Number	Terminal Block Catalog Number
		1	Left <sup>③</sup>	B01		B02	B03
	Right <sup>④</sup>	B05	B06	B07	B08	A1L3RPK	A1L3RTK
2	Left <sup>③</sup>	B09	B10	—	B11	A2L3LPK	A2L3LTK
	Right <sup>④</sup>	B12	B13	—	B14	A2L3RPK	A2L3RTK

## L-, HMCP (L) and (M) Frames and Alarm Switch

Number of Sets of Contacts (1M and 1B)	Mounting Location (Pole)	Factory Mounted Connection Type and Location 18-Inch (457.2 mm) Pigtail Leads			Terminal Block Same Side Suffix Number	Field Mounted Field Installation Kits <sup>①</sup>	
		Same Side Suffix Number	Rear <sup>②</sup> Suffix Number	Opposite Side Suffix Number		Pigtail Leads Catalog Number	Terminal Block Catalog Number
		1	Left <sup>③</sup>	B01		B02	B03
	Right	B05	B06	B07	B08	A1L4RPK	A1L4RTK
2	Left <sup>③</sup>	B09	B10	—	B11	A2L4LPK	A2L4LTK
	Right	B12	B13	—	B14	A2L4RPK	A2L4RTK

## N-Frame and HMCP (N) Alarm Switch

Number of Sets of Contacts (1M and 1B)	Mounting Location (Pole)	Factory Mounted Connection Type and Location 18-Inch (457.2 mm) Pigtail Leads			Terminal Block Same Side Suffix Number	Field Mounted Field Installation Kits <sup>⑤</sup>	
		Same Side Suffix Number	Rear <sup>②</sup> Suffix Number	Opposite Side Suffix Number		Pigtail Leads Catalog Number	Terminal Block Catalog Number
		1	Left	B01		B02	B03
	Right <sup>③</sup>	B05	B06	B07	B08	A1L5RPK	A1L5RTK
2	Left	B09	B10	—	B11	A2L5LPK	A2L5LTK
	Right <sup>③</sup>	B12	B13	—	B14	A2L5RPK	A2L5RTK

## R-Frame Alarm Switch (RH Only)

Number of Contacts (Make and Break)	Factory Mounted Connection Type and Location 18-Inch (457.2 mm) Pigtail Leads Suffix Number <sup>⑥</sup>	Field Mounted Field Installation Kits <sup>⑤</sup> Pigtail Leads Catalog Number <sup>⑥</sup>
	1	B05
2	B12	A2L6RPK

## Notes

- ① Listed with Underwriters Laboratories; for field installation on interchangeable trip unit breakers under E64983.
- ② Standard mounting location.
- ③ Standard mounting location—leads exit rear of breaker.
- ④ Breakers with K-Frame OPTIM 550 can only accept accessories in left pole.
- ⑤ Listed with Underwriters Laboratories for field installation under E64983.
- ⑥ A maximum of three ASL plug-in modules may be installed in a circuit breaker.

## Auxiliary Switch

## Auxiliary Switch

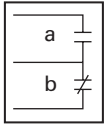

## G-Frame Auxiliary Switch (RH Only)

Electrical Ratings			Contact Arrangement	Factory Suffix	Catalog Number <sup>①②</sup>
Volts	Frequency	Amperes			
240	50/60 Hz	6	1a/1b	A3	1288C74G03
240	50/60 Hz	6	2a/2b	A6	1288C73G03

## F-Frame and HMCP (F) Auxiliary Switch

Number of Contacts A and B	Mounting Location (Pole)	Factory Mounted Connection Type and Location 18-Inch (457.2 mm) Pigtail Leads				Factory Installation Kit <sup>④</sup>	
		Same Side Suffix Number	Rear <sup>③</sup> Suffix Number	Opposite Side Suffix Number	Terminal Block Same Side Suffix Number	Pigtail Leads Catalog Number	Terminal Block Catalog Number
		1	Left <sup>⑤</sup>	A01	A02	A03	A04
	Left <sup>⑤</sup>	A15 <sup>⑦</sup>	A16 <sup>⑦</sup>	A17 <sup>⑦</sup>	—	E1X1PK	—
	Right or Neutral <sup>⑥</sup>	A05	A06	A07	A08	A1X1PK	A1X1RTK <sup>⑧</sup>
	Right or Neutral <sup>⑥</sup>	A18 <sup>⑦</sup>	A19 <sup>⑦</sup>	A20 <sup>⑦</sup>	—	—	—
2	Left <sup>⑤</sup>	A09	A10	—	A11	A2X1LPK	A2X1LTK
	Left <sup>⑤</sup>	A21 <sup>⑦</sup>	A22 <sup>⑦</sup>	—	—	E2X1LPK	—
	Right or Neutral <sup>⑥</sup>	A12	A13	—	A14	A2X1RPK	A2X1RTK <sup>⑧</sup>
	Right or Neutral <sup>⑥</sup>	A23 <sup>⑦</sup>	A24 <sup>⑦</sup>	—	—	E2X1RPK	—

F-Frame with Electronic Trip Unit Auxiliary Switch <sup>⑨</sup>

Number of Contacts A and B	Mounting Location (Pole)	Factory Mounted Connection Type and Location 18-Inch (457.2 mm) Pigtail Leads				Factory Installation Kit <sup>④</sup>	
		Same Side Suffix Number	Rear <sup>③</sup> Suffix Number	Opposite Side Suffix Number	Terminal Block Same Side Suffix Number	Pigtail Leads Catalog Number	Terminal Block Catalog Number
		<b>Trip Unit Type 310+</b>					
1	Right	A30	A31	A32	—	—	—
<b>Trip Unit Type 210+</b>							
1	Right	A33	A34	A35	—	—	—

## J-Frame and HMCP (J) Auxiliary Switch

Number of Contacts A and B	Mounting Location (Pole)	Factory Mounted Connection Type and Location 18-Inch (457.2 mm) Pigtail Leads				Field Mounted Factory Installation Kit <sup>⑩</sup>	
		Same Side Suffix Number	Rear <sup>③</sup> Suffix Number	Opposite Side Suffix Number	Terminal Block Same Side Suffix Number	Pigtail Leads Catalog Number	Terminal Block Catalog Number
		1	Left	A01	A02	A03	A04
	Right <sup>⑪</sup>	A05	A06	A07	A08	A1X2PK	A1X2RTK <sup>⑧</sup>
2	Left	A09	A10	—	A11	A2X2PK	A2X2LTK
	Right <sup>⑪</sup>	A12	A13	—	A14	A2X2PK	A2X2RTK <sup>⑧</sup>

## Notes

- ① Includes 24-inch external pigtail leads, 18 AWG (16–0.010).
- ② A maximum of two internal accessories may be mounted in a three-pole circuit breaker. Suitable for mounting in right pole only of two- or three-pole breaker.
- ③ Standard pigtail lead exit location.
- ④ Not listed with Underwriters Laboratories; for field installation.
- ⑤ Pigtail wire size: 18 AWG (0.82 mm<sup>2</sup>).
- ⑥ Not for use on F-Frame with electronic trip unit.
- ⑦ 125 volts (max.), 50/60 Hz switch for use in electronic circuit of 100 micro amperes and 15 Vdc minimum.
- ⑧ Not for use on four-pole circuit breakers.
- ⑨ Only for use on three-pole F-Frame breakers with electronic trip unit. Installation auxiliary switch for FD electronic breakers on right pole must be performed at breaker factory.
- ⑩ Listed with Underwriters Laboratories for field installation or interchangeable trip unit breakers under E64983.
- ⑪ Standard mounting location—leads exit rear of breaker.

## K-Frame and HMCP (K) Auxiliary Switch

Number of Contacts A and B	Mounting Location (Pole)	Factory Mounted Connection Type and Location 18-Inch (457.2 mm) Pigtail Leads			Field Mounted Factory Installation Kit ①		
		Same Side	Rear ②	Opposite Side	Pigtail Leads	Terminal Block	
		Suffix Number	Suffix Number	Suffix Number	Same Side Suffix Number	Terminal Block Catalog Number	
1	Left	A01	A02	A03	A04	A1X3PK	A1X3LTK
	Right ②③	A05	A06	A07	A08	A1X3PK	A1X3RTK ④
2	Left	A09	A10	—	A11	A2X3PK	A2X3LTK
	Right ②③	A12	A13	—	A14	A2X3PK	A2X3RTK ④
	Right	A21	A22	—	—	1482D28G10 ⑥⑦	—
3	Left	A18	—	—	A15	A3X3LPK	A3X3LTK
	Right ③	A17	—	—	A16	A3X3RPK	A3X3RTK ④

## L-, HMCP (L) and (M) Frames and Auxiliary Switch

Number of Contacts A and B	Mounting Location (Pole)	Factory Mounted Connection Type and Location 18-Inch (457.2 mm) Pigtail Leads			Field Mounted Factory Installation Kit ①		
		Same Side	Rear ②	Opposite Side	Pigtail Leads	Terminal Block	
		Suffix Number	Suffix Number	Suffix Number	Same Side Suffix Number	Terminal Block Catalog Number	
1	Left	A01	A02	A03	A04	A1X4PK	A1X4LTK
	Right ②	A05	A06	A07	A08	A1X4PK	A1X4RTK ④
2	Left	A09	A10	—	A11	A2X4PK	A2X4LTK
	Right ②	A12	A13	—	A14	A2X4PK	A2X4RTK ④
3	Left	A18	—	—	A15	A3X4PK	A3X4LTK
	Right ②	A17	—	—	A16	A3X4PK	A3X4RTK ④

## N-Frame and HMCP (N) Auxiliary Switch

Number of Contacts A and B	Mounting Location (Pole)	Factory Mounted Connection Type and Location 18-Inch (457.2 mm) Pigtail Leads			Field Mounted Factory Installation Kit ①		
		Same Side	Rear ②	Opposite Side	Pigtail Leads	Terminal Block	
		Suffix Number	Suffix Number	Suffix Number	Same Side Suffix Number	Terminal Block Catalog Number	
1	Left	A01	A02	A03	A04	A1X5PK	A1X5LTK
	Right ②	A05	A06	A07	A08	A1X5PK	A1X5RTK ④
2	Left	A09	A10	—	A11	A2X5PK	A2X5LTK
	Right ②	A12	A13	—	A14	A2X5PK	A2X5RTK ④
3	Left	A18	—	—	A15	A3X5LPK	A3X5LTK
	Right ②	A17	—	—	A16	A3X5RPK	A3X5RTK ④

## R-Frame Auxiliary Switch (RH Only)

Number of Contacts A and B	Factory Mounted Connection Type and Location 18-Inch (457.2 mm) Pigtail Leads	Field Mounted Field Installation Kits ①
	Suffix Number ⑤	Pigtail Leads Catalog Number ⑤
2	A12	A2X6RPK
4	A19	A4X6RPK

## Notes

- ① Listed with Underwriters Laboratories for field installation under E64983.
- ② Standard mounting location—leads exit rear of breaker.
- ③ Breakers with K-Frame OPTIM 550 can only accept accessories in left pole.
- ④ Not for use on four-pole circuit breakers.
- ⑤ A maximum of two auxiliary switches (any combination of 2a/2b or 4a/4b plug-in modules may be installed in a circuit breaker).
- ⑥ This option is not field installable.
- ⑦ Available on the OPTIM 550 only. Communications are not available with this option.

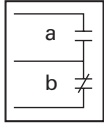
**Auxiliary Switch and Alarm Switch Combination****Auxiliary Switch and Alarm Switch Combination****F-Frame Auxiliary Switch and Alarm Switch Combination** <sup>①</sup>

Mounting Location (Pole)	Factory Mounted Connection Type and Location			Factory Installation Kit <sup>②</sup>	
	18-Inch (457 mm) Pigtail Leads			Terminal Block	Pigtail Leads
	Same Side	Rear <sup>③</sup>	Terminal Block	Same Side	Terminal Block
	Suffix Number	Suffix Number	Suffix Number	Catalog Number	Catalog Number
Left <sup>③</sup>	C01	C02	C03	AAL1LPK	AAL1LTK
Right	C04	C05	C06	AAL1RPK	AAL1RTK <sup>④</sup>

**F-Frame HMCP Auxiliary Switch and Alarm Switch Combination**

Mounting Location (Pole)	Factory Mounted Connection Type and Location			Factory Installation Kit <sup>②</sup>	
	18-Inch (457 mm) Pigtail Leads			Terminal Block	Pigtail Leads
	Same Side	Rear <sup>③</sup>	Terminal Block	Same Side	Terminal Block
	Suffix Number	Suffix Number	Suffix Number	Catalog Number	Catalog Number
Left <sup>④</sup>	C01	C02	C03	MAAL1LPK	MAAL1LTK
Right	C04	C05	C06	MAAL1RPK	MAAL1RPK

**J-Frame and HMCP (J) Auxiliary Switch and Alarm Switch Combination**

Number of Sets of Contacts (1A and 1B) (1M–1B)	Mounting Location (Pole)	Factory Mounted Connection Type and Location			Terminal Block	Field Mounted Field Installation Kits <sup>⑤</sup>	
		18-Inch (457 mm) Pigtail Leads			Terminal Block	Pigtail Leads	Terminal Block
		Same Side	Rear <sup>⑥</sup>	Opposite Side	Same Side	Terminal Block	Pigtail Leads
		Suffix Number	Suffix Number	Suffix Number	Suffix Number	Catalog Number	Catalog Number
1	Left	C01	C02	—	C03	AAL2LPK	AAL2LTK
	Right <sup>④</sup>	C04	C05	—	C06	AAL2RPK	AAL2RTK <sup>④</sup>

**K-Frame and HMCP (K) Auxiliary Switch and Alarm Switch Combination**

Number of Sets of Contacts (1A and 1B) (1M–1B)	Mounting Location (Pole)	Factory Mounted Connection Type and Location			Terminal Block	Field Mounted Field Installation Kits <sup>⑤</sup>	
		18-Inch (457 mm) Pigtail Leads			Terminal Block	Pigtail Leads	Terminal Block
		Same Side	Rear <sup>⑥</sup>	Opposite Side	Same Side	Terminal Block	Pigtail Leads
		Suffix Number	Suffix Number	Suffix Number	Suffix Number	Catalog Number	Catalog Number
1	Left	C01	C02	—	C03	AAL3LPK	AAL3LTK
	Right <sup>⑥⑦</sup>	C04	C05	—	C06	AAL3RPK <sup>⑧</sup>	AAL3RTK
	Right	C07	C08	—	—	1482D28G09 <sup>⑧⑨</sup>	—

**Notes**

- ① Auxiliary switch and alarm switch combination options (Cxx) are not available on FDE 310+ with LSG or LSIG trip units due to exit wire limitations. To obtain both features, order a left mounting alarm switch (B01-B04 or B09-B11), and right mounting auxiliary switch (A30-A32).
- ② Not listed with Underwriters Laboratories for field installation.
- ③ Standard mounting location.
- ④ Not for use on four-pole circuit breakers.
- ⑤ Listed with Underwriters Laboratories for field installation of interchangeable trip unit breakers under E64983.
- ⑥ Standard mounting location—leads exit rear of breaker.
- ⑦ Breakers with K-Frame OPTIM 550 can only accept accessories in left pole.
- ⑧ Will not install on OPTIM Trip (RH).
- ⑨ Available on the OPTIM 550 only. Communications are not available with this option.
- ⑩ This option is not field installable.

## L-, HMCP (L) and (M) Frames and Auxiliary Switch and Alarm Switch Combination

Number of Sets of Contacts	Mounting Location (Pole)	Factory Mounted Connection Type and Location 18-Inch (457 mm) Pigtail Leads			Terminal Block Same Side Suffix Number	Field Mounted Field Installation Kits <sup>①</sup>	
		Same Side Suffix Number	Rear <sup>②</sup> Suffix Number	Opposite Side Suffix Number		Pigtail Leads Catalog Number	Terminal Block Catalog Number
		1A, 1B and 1 Make/1 Break	Left	C01		C02	—
	Right <sup>②</sup>	C04	C05	—	C06	AA114RPK	AA114RTK <sup>③</sup>
2A, 2B and 1 Make/1 Break	Left	C07	C08	—	C12	AA214LPK	AA214LTK
	Right <sup>②</sup>	C10	C11	—	C13	AA214RPK	AA214RTK <sup>③</sup>
3A, 3B and 1 Make/1 Break	Left	C14	—	—	—	AA314LPK	—
	Right <sup>②</sup>	C15	—	—	—	AA314RPK	—

## N-Frame and HMCP (N) Auxiliary Switch and Alarm Switch Combination

Number of Sets of Contacts	Mounting Location (Pole)	Factory Mounted Connection Type and Location 18-Inch (457 mm) Pigtail Leads			Terminal Block Same Side Suffix Number	Field Mounted Field Installation Kits <sup>①</sup>	
		Same Side Suffix Number	Rear <sup>②</sup> Suffix Number	Opposite Side Suffix Number		Pigtail Leads Catalog Number	Terminal Block Catalog Number
		1A, 1B and 1 Make/1 Break	Left	C01		C02	—
	Right <sup>②</sup>	C04	C05	—	C06	AA115RPK	AA115RTK <sup>③</sup>
2A, 2B and 1 Make/1 Break	Left	C07	C08	—	C12	AA215LPK	AA215LTK
	Right <sup>②</sup>	C10	C11	—	C13	AA215RPK	AA215RTK <sup>③</sup>

**Notes**

- ① Listed with Underwriters Laboratories for field installation under E64983.  
 ② Standard mounting location—leads exit rear of breaker.  
 ③ Not for use on four-pole circuit breaker.

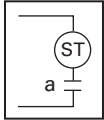
**Shunt Trip****Shunt Trip****G-Frame Shunt Trip (LH Three-Pole Only)**

Electrical Ratings				
Volts	Frequency	Amperes	Suffix Number	Catalog Number
120	50/60 Hz	1.1	<b>S1</b>	<b>1373D62G01</b>
240	50/60 Hz	2.1	<b>S2</b>	<b>1373D62G02</b>
12	DC	2.8	<b>S3</b>	<b>1373D62G15</b>
24	DC	5.7	<b>S4</b>	<b>1373D62G16</b>
24	60 Hz	—	<b>S7</b>	<b>1373D62G20</b>

**F-Frame and HMCP (F) Shunt Trip**

Voltage Rating (AC Frequency = 50/60 Hz)	Factory Mounted Connection Type and Location			Factory Installation Kit ①		
	18-Inch (457.2 mm) Pigtail Leads ②			Terminal Block	Pigtail Leads	Terminal Block
	Same Side	Rear ③	Opposite Side	Same Side		
	Suffix Number	Suffix Number	Suffix Number	Suffix Number	Catalog Number	Catalog Number
<b>Left-Pole Mounting AC/DC Ratings</b>						
12–24 Vac or Vdc	<b>S01</b>	<b>S02</b>	<b>S03</b>	<b>S04</b>	<b>SNT1LP03K</b>	<b>SNT1LT03K</b>
48–127 Vac or 48–60 Vdc ④	<b>S05</b>	<b>S06</b>	<b>S07</b>	<b>S08</b>	<b>SNT1LP08K</b>	<b>SNT1LT08K</b>
208–380 Vac or 110–127 Vdc	<b>S09</b>	<b>S10</b>	<b>S11</b>	<b>S12</b>	<b>SNT1LP12K</b>	<b>SNT1LT12K</b>
415–600 Vac or 220–250 Vdc	<b>S13</b>	<b>S14</b>	<b>S15</b>	<b>S16</b>	<b>SNT1LP18K</b>	<b>SNT1LT18K</b>
<b>Right- or Neutral-Pole Mounting AC/DC Ratings ⑤</b>						
12–24 Vac or Vdc	<b>S17</b>	<b>S18</b>	<b>S19</b>	<b>S20</b>	<b>SNT1RP03K</b>	<b>SNT1RT03K ⑥</b>
48–127 Vac or 48–60 Vdc ④	<b>S21</b>	<b>S22</b>	<b>S23</b>	<b>S24</b>	<b>SNT1RP08K</b>	<b>SNT1RT08K ⑥</b>
208–380 Vac or 110–127 Vdc	<b>S25</b>	<b>S26</b>	<b>S27</b>	<b>S28</b>	<b>SNT1RP12K</b>	<b>SNT1RT12K ⑥</b>
415–600 Vac or 220–250 Vdc	<b>S29</b>	<b>S30</b>	<b>S31</b>	<b>S32</b>	<b>SNT1RP18K</b>	<b>SNT1RT18K ⑥</b>

**Notes**

① Not listed with Underwriters Laboratories, for field installation.

② Pigtail wire size: 18 AWG (0.82 mm<sup>2</sup>).

③ Standard pigtail lead exit location.

④ 120 Vac marked suitable for ground fault protection devices.

⑤ Standard mounting location.

⑥ Not for use on four-pole circuit breakers.

G-Frame circuit breakers are factory sealed. Underwriters Laboratories requires that internal accessories be installed at the factory.

Internal accessories are UL listed for factory installation under E7819.

Where local codes and standards permit and UL listing is not required, internal accessories can be field installed.

Accessory installation should be done before the circuit breaker is mounted and connected.

# 2.3

## Molded Case Circuit Breakers

### Series C

2

#### J-Frame and HMCP (J) Shunt Trip

Voltage Rating (AC Frequency = 50/60 Hz)	Factory Mounted Connection Type and Location 18-Inch (457.2 mm) Pigtail Leads				Field Mounted Field Installation Kits <sup>①</sup>	
	Same Side		Opposite Side	Terminal Block		
	Suffix Number	Rear <sup>②</sup> Suffix Number		Same Side	Pigtail Leads	
	Suffix Number	Suffix Number	Suffix Number	Suffix Number	Catalog Number	Catalog Number
<b>Left-Pole Mounting AC/DC Ratings <sup>②</sup></b>						
12–24 Vac or Vdc	S41	S42	S43	S44	SNT2P04K	SNT2T04K
48–60 Vac or Vdc	S49	S50	S51	S52	SNT2P06K	SNT2T06K
110–240 Vac or 110–125 Vdc <sup>③</sup>	S09	S10	S11	S12	SNT2P11K	SNT2T11K
380–440 Vac or 220–250 Vdc	S13	S14	S15	S16	SNT2P14K	SNT2T14K
480–600 Vac	S17	S18	S19	S20	SNT2P18K	SNT2T18K
<b>Right- or Neutral-Pole Mounting AC/DC Ratings</b>						
12–24 Vac or Vdc	S45	S46	S47	S48	SNT2P04K	SNT2T04K <sup>④</sup>
48–60 Vac or Vdc	S53	S54	S55	S56	SNT2P06K	SNT2T06K <sup>④</sup>
110–240 Vac or 110–125 Vdc <sup>③</sup>	S29	S30	S31	S32	SNT2P11K	SNT2T11K <sup>④</sup>
380–440 Vac or 220–250 Vdc	S33	S34	S35	S36	SNT2P14K	SNT2T14K <sup>④</sup>
480–600 Vac	S37	S38	S39	S40	SNT2P18K	SNT2T18K <sup>④</sup>

#### K-Frame and HMCP (K) Shunt Trip

Voltage Rating (AC Frequency = 50/60 Hz)	Factory Mounted Connection Type and Location 18-Inch (457.2 mm) Pigtail Leads				Field Mounted Field Installation Kits <sup>①</sup>	
	Same Side		Opposite Side	Terminal Block		
	Suffix Number	Rear <sup>②</sup> Suffix Number		Same Side	Pigtail Leads	
	Suffix Number	Suffix Number	Suffix Number	Suffix Number	Catalog Number	Catalog Number
<b>Left-Pole Mounting AC/DC Ratings <sup>②</sup></b>						
12–24 Vac or Vdc	S41	S42	S43	S44	SNT3P04K	SNT3T04K
48–60 Vac or Vdc	S49	S50	S51	S52	SNT3P06K	SNT3T06K
110–240 Vac or 110–125 Vdc <sup>③</sup>	S09	S10	S11	S12	SNT3P11K	SNT3T11K
380–440 Vac or 220–250 Vdc	S13	S14	S15	S16	SNT3P14K	SNT3T14K
480–600 Vac	S17	S18	S19	S20	SNT3P18K	SNT3T18K
<b>Right- or Neutral-Pole Mounting AC/DC Ratings <sup>⑤⑥</sup></b>						
12–24 Vac or Vdc	S45	S46	S47	S48	SNT3P04K	SNT3T04K <sup>④</sup>
48–60 Vac or Vdc	S53	S54	S55	S56	SNT3P06K	SNT3T06K <sup>④</sup>
110–240 Vac or 110–125 Vdc <sup>③</sup>	S29	S30	S31	S32	SNT3P11K	SNT3T11K <sup>④</sup>
380–440 Vac or 220–250 Vdc	S33	S34	S35	S36	SNT3P14K	SNT3T14K <sup>④</sup>
480–600 Vac	S37	S38	S39	S40	SNT3P18K	SNT3T18K <sup>④</sup>

#### Notes

- ① Listed with Underwriters Laboratories for field installation under E64983.
- ② Standard mounting location—leads exit rear of breaker.
- ③ Suitable for use with Class 1 ground fault sensing element.
- ④ Not for use on four-pole circuit breakers.
- ⑤ For use with KT (thermal-magnetic) trip units only.
- ⑥ Breakers with K-Frame OPTIM 550 can only accept accessories in left pole.

## L-, HMCP (L) and (M) Frames and Shunt Trip

Voltage Rating (AC Frequency = 50/60 Hz)	Factory Mounted Connection Type and Location 18-Inch (457.2 mm) Pigtail Leads				Field Mounted Field Installation Kits <sup>①</sup>	
	Same Side	Rear <sup>②</sup>	Opposite Side	Terminal Block Same Side	Pigtail Leads	Terminal Block
	Suffix Number	Suffix Number	Suffix Number	Suffix Number	Catalog Number	Catalog Number
<b>Left-Pole Mounting AC/DC Ratings <sup>②</sup></b>						
12–24 Vac or Vdc	S01	S02	S03	S04	SNT4LP03K	SNT4LT03K
48–60 Vac	S05	S06	S07	S08	SNT4LP05K	SNT4LT05K
48–60 Vdc	S85	S86	S87	—	SNT4LP23K	SNT4LT23K
110–240 Vac	S09	S10	S11	S12	SNT4LP11K	SNT4LT11K
110–125 Vdc	S41	S42	S43	S44	SNT4LP26K	SNT4LT26K
380–440 Vac or 220–250 Vdc	S13	S14	S15	S16	SNT4LP14K	SNT4LT14K
480–600 Vac	S17	S18	S19	S20	SNT4LP18K	SNT4LT18K
<b>Right-Pole Mounting AC/DC Ratings <sup>③</sup></b>						
12–24 Vac or Vdc	S21	S22	S23	S24	SNT4RP03K	SNT4RT03K
48–60 Vac	S25	S26	S27	S28	SNT4RP05K	SNT4RT05K
48–60 Vdc	S88	S89	S90	—	SNT4RP23K	SNT4RT23K
110–240 Vac	S29	S30	S31	S32	SNT4RP11K	SNT4RT11K
110–125 Vdc	S45	S46	S47	S48	SNT4RP26K	SNT4RT26K
380–440 Vac or 220–250 Vdc	S33	S34	S35	S36	SNT4RP14K	SNT4RT14K
480–600 Vac	S37	S38	S39	S40	SNT4RP18K	SNT4RT18K

**Notes**

- <sup>①</sup> Listed with Underwriters Laboratories, for field installation under E64983.  
<sup>②</sup> Standard mounting location—leads exit rear of breaker.  
<sup>③</sup> For use with LT (thermal-magnetic) three-pole trip units only.

## N-Frame and HMCP (N) Shunt Trip

Voltage Rating (AC Frequency = 50/60 Hz)	Factory Mounted Connection Type and Location 18-Inch (457.2 mm) Pigtail Leads			Field Mounted Field Installation Kits <sup>①</sup>		
	Same Side	Rear <sup>②</sup>	Opposite Side	Terminal Block Same Side	Pigtail Leads	Terminal Block
	Suffix Number	Suffix Number	Suffix Number	Suffix Number	Catalog Number	Catalog Number
<b>Left-Pole Mounting AC/DC Ratings <sup>②</sup></b>						
9–24 Vac or Vdc	S01	S02	S03	S04	SNT5LP03K	SNT5LT03K
48–60 Vac	S05	S06	S07	S08	SNT5LP05K	SNT5LT05K
110–240 Vac <sup>③</sup>	S09	S10	S11	S12	SNT5LP11K	SNT5LT11K
110–125 Vdc	S41	S42	S43	S44	SNT5LP26K	SNT5LT26K
380–440 Vac or 220–250 Vdc	S13	S14	S15	S16	SNT5LP14K	SNT5LT14K
480–600 Vac	S17	S18	S19	S20	SNT5LP18K	SNT5LT18K
48–60 Vdc	S21	S22	S23	S24	SNT5LP23K	SNT5LT23K

## R-Frame Shunt Trip (RH Only)

Voltage Rating (AC Frequency = 50/60 Hz)	Factory Mounted Connection Type and Location 18-Inch (457.2 mm) Pigtail Leads	Field Mounted Field Installation Kits <sup>①</sup>
	Suffix Number <sup>④</sup>	Pigtail Leads Catalog Number <sup>④</sup>
24 Vac or Vdc	S21	SNT6P03K
48–60 Vac	S25	SNT6P05K
110–240 Vac	S29	SNT6P11K
380–440 Vac or 220–250 Vdc	S33	SNT6P14K
480–600 Vac	S37	SNT6P18K
48–60 Vdc	S88	SNT6P23K
110–125 Vdc	S45	SNT6P26K

**Notes**

- <sup>①</sup> Listed with Underwriters Laboratories for field installation under E64983.  
<sup>②</sup> Standard mounting location—leads exit rear of breaker.  
<sup>③</sup> Supply voltages suitable for use with Class 1 GFP devices. Marking label included with accessory kits.  
<sup>④</sup> A maximum of two shunt trip plug-in modules may be installed in a circuit breaker.

### Low Energy Shunt Trip Ordering Information

Select shunt trip catalog number for the voltage within the indicated voltage range. Shunt trip coils are designed to be applied at specific AC or DC voltages within the voltage range shown. Electrical ratings are also shown on applicable circuit breaker accessory nameplates.

#### Low Energy Shunt Trip

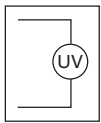

#### F-, J-, K-, L-, M-, N- and R-Frames and HMCPs Low Energy Shunt Trip <sup>①</sup>

Mounting Positions (Pole)	Factory Mounted Connection Type and Location 18-Inch (457.2 mm) Pigtail Leads			Field Mounted Field Installation Kits <sup>②</sup> Terminal Block		
	Same Side	Rear <sup>③</sup>	Opposite Side	Same Side	Pigtail Leads	Terminal Block
	Suffix Number	Suffix Number	Suffix Number	Suffix Number	Catalog Number	Catalog Number
<b>F-Frame</b>						
Left	N01	N02	N03	N04	LST1LPK <sup>④</sup>	LST1LTK <sup>④</sup>
Right <sup>③</sup>	N05	N06	N07	N08	LST1RPK <sup>④</sup>	LST1RTK <sup>④</sup>
<b>J-Frame</b>						
Left	N01	N02	N03	—	LST2LPK	—
Right <sup>③</sup>	N05	N06	N07	—	LST2RPK	—
<b>K-Frame</b>						
Left <sup>③</sup>	N01	N02	N03	—	LST3LPK	—
Right <sup>⑤⑥</sup>	N05	N06	N07	—	LST3RPK	—
<b>L- and M-Frames</b>						
Left	N01	N02	N03	—	LST4LPK	—
Right	N05	N06	N07	—	LST4RPK	—
<b>N-Frame</b>						
Left <sup>③</sup>	N01	N02	N03	—	LST5LPK	—
<b>R-Frame</b>						
Right	N01	—	—	—	LST6RPK	—

#### Notes

- ① Cutoff provisions required in control circuit.
- ② Listed with Underwriters Laboratories for field installation under E64983.
- ③ Standard mounting location—leads exit rear of breaker.
- ④ For F-Frame HMCP, add an "M" to beginning of catalog number. Field Installation Kit referenced for factory use only, not UL listed for field installation.
- ⑤ For use with thermal-magnetic trip units only.
- ⑥ Breakers with K-Frame OPTIM 550 can only accept accessories in left pole.

### Undervoltage Release Mechanism Ordering Information

2

Select handle reset undervoltage release mechanism catalog number for the voltage within the indicated voltage range. Undervoltage release mechanism coils are designed to be applied at specific AC or DC voltages within the voltage range shown on applicable circuit breaker accessory nameplates.

#### Undervoltage Release Mechanism

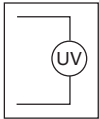

#### G-Frame Undervoltage Release Mechanism (LH Three-Pole Only)

##### Electrical Ratings

Volts (AC Only)	Frequency (Hz)	Amperes	Style Numbers <sup>①②③</sup>	Factory Suffix
120	50/60	0.05	<b>1373D62G03</b>	<b>T1</b>
24	50/60	0.22	<b>1373D62G04</b>	<b>T2</b>
48	50/60	0.11	<b>1373D62G05</b>	<b>T3</b>
60	50/60	0.10	<b>1373D62G06</b>	<b>T4</b>
110	50	0.049	<b>1373D62G07</b>	<b>T5</b>
208	60	0.026	<b>1373D62G08</b>	<b>T6</b>
220	50	0.025	<b>1373D62G09</b>	<b>T7</b>
240	50/60	0.024	<b>1373D62G10</b>	<b>T8</b>
380	50	0.015	<b>1373D62G11</b>	<b>T9</b>
415	50	0.013	<b>1373D62G12</b>	<b>T10</b>
440	50	0.012	<b>1373D62G13</b>	<b>T11</b>
480	60	0.01	<b>1373D62G14</b>	<b>T12</b>

##### Notes

- ① Includes 24-inch (609.6 mm) external pigtail leads, 18 AWG (16–0.010).
- ② A maximum of two internal accessories may be mounted in a three-pole circuit breaker.
- ③ Suitable for mounting in left pole only of three-pole breaker.

G-Frame circuit breakers are factory sealed. Underwriters Laboratories requires that internal accessories be installed at the factory.

Internal accessories are UL listed for factory installation under E7819.

Where local codes and standards permit and UL listing is not required, internal accessories can be field installed. Accessory installation should be done before the circuit breaker is mounted and connected.

### F-Frame Factory Mounted (For F-Frame Breaker and F-Frame HMCP) Undervoltage Release Mechanism

Voltage Rating (AC Freq. = 50/60 Hz)	Connection Type and Location 18-Inch Pigtail Leads			Terminal Block Same Side Suffix Number
	Same Side Suffix Number	Rear <sup>①</sup> Suffix Number	Opposite Side Suffix Number	
<b>Left-Pole Mounting AC Ratings</b>				
12 Vac	U01	U02	U03	U04
24 Vac	U05	U06	U07	U08
48 Vac	U37	U38	U39	U40
60 Vac	U97	U98	U99	U100
110–127 Vac	U13	U14	U15	U16
208–240 Vac	U17	U18	U19	U20
380–480 Vac	U21	U22	U23	U24
525–600 Vac	U25	U26	U27	U28
<b>Right-Pole Mounting AC Ratings <sup>②③</sup></b>				
12 Vac	U49	U50	U51	U52
24 Vac	U53	U54	U55	U56
48 Vac	U85	U86	U87	U88
60 Vac	U101	U102	U103	U104
110–127 Vac	U61	U62	U63	U64
208–240 Vac	U65	U66	U67	U68
380–480 Vac	U69	U70	U71	U72
525–600 Vac	U73	U74	U75	U76
<b>Left-Pole Mounting DC Ratings</b>				
12 Vdc	U29	U30	U31	U32
24 Vdc	U33	U34	U35	U36
48 Vdc	U37	U38	U39	U40
60 Vdc	U97	U98	U99	U100
110–127 Vdc	U41	U42	U43	U44
220–250 Vdc	U45	U46	U47	U48
<b>Right-Pole Mounting DC Ratings <sup>②③</sup></b>				
12 Vdc	U77	U78	U79	U80
24 Vdc	U81	U82	U83	U84
48 Vdc	U85	U86	U87	U88
60 Vdc	U101	U102	U103	U104
110–127 Vdc	U89	U90	U91	U92
220–250 Vdc	U93	U94	U95	U96

#### Notes

- ① Standard pigtail lead exit location.
- ② Standard mounting location.
- ③ Not for use on right pole of four-pole circuit breaker.

F-Frame circuit breakers are factory sealed. Underwriters Laboratories requires that internal accessories be installed at the factory.

Internal accessories are UL listed for factory installation under E7819.

Where local codes and standards permit and UL listing is not required, internal accessories can be field installed. Accessory installation should be done before the circuit breaker is mounted and connected.

## F-Frame Field Mounted Undervoltage Release Mechanism

Voltage Rating (AC Freq. = 50/60 Hz)	F-Frame Breaker Factory Installation Kits <sup>①</sup>		F-Frame Breaker HMCP	
	Pigtail Leads	Terminal Block	Pigtail Leads	Terminal Block
	Catalog Number	Catalog Number	Catalog Number	Catalog Number
<b>Left-Pole Mounting AC Ratings</b>				
12 Vac	UVH1LP02K	UVH1LT02K	MUVH1LP02K	MUVH1LT02K
24 Vac	UVH1LP03K	UVH1LT03K	MUVH1LP03K	MUVH1LT03K
48 Vac	UVH1LP22K	UVH1LT22K	MUVH1LP22K	MUVH1LT22K
60 Vac	UVH1LP24K	UVH1LT24K	MUVH1LP24K	MUVH1LT24K
110–127 Vac	UVH1LP08K	UVH1LT08K	MUVH1LP08K	MUVH1LT08K
208–240 Vac	UVH1LP11K	UVH1LT11K	MUVH1LP11K	MUVH1LT11K
380–480 Vac	UVH1LP15K	UVH1LT15K	MUVH1LP15K	MUVH1LT15K
525–600 Vac	UVH1LP18K	UVH1LT18K	MUVH1LP18K	MUVH1LT18K
<b>Right-Pole Mounting AC Ratings <sup>②③</sup></b>				
12 Vac	UVH1RP02K	UVH1RT02K	MUVH1RP02K	MUVH1RT02K
24 Vac	UVH1RP03K	UVH1RT03K	MUVH1RP03K	MUVH1RT03K
48 Vac	UVH1RP22K	UVH1RT22K	MUVH1RP22K	MUVH1RT22K
60 Vac	UVH1RP24K	UVH1RT24K	MUVH1RP24K	MUVH1RT24K
110–127 Vac	UVH1RP08K	UVH1RT08K	MUVH1RP08K	MUVH1RT08K
208–240 Vac	UVH1RP11K	UVH1RT11K	MUVH1RP11K	MUVH1RT11K
380–480 Vac	UVH1RP15K	UVH1RT15K	MUVH1RP15K	MUVH1RT15K
525–600 Vac	UVH1RP18K	UVH1RT18K	MUVH1RP18K	MUVH1RT18K
<b>Left-Pole Mounting DC Ratings</b>				
12 Vdc	UVH1LP20K	UVH1LT20K	MUVH1LP20K	MUVH1LT20K
24 Vdc	UVH1LP21K	UVH1LT21K	MUVH1LP21K	MUVH1LT21K
48 Vdc	UVH1LP22K	UVH1LT22K	MUVH1LP22K	MUVH1LT22K
60 Vdc	UVH1LP24K	UVH1LT24K	MUVH1LP24K	MUVH1LT24K
110–127 Vdc	UVH1LP26K	UVH1LT26K	MUVH1LP26K	MUVH1LT26K
220–250 Vdc	UVH1LP28K	UVH1LT28K	MUVH1LP28K	MUVH1LT28K
<b>Right-Pole Mounting DC Ratings <sup>②③</sup></b>				
12 Vdc	UVH1RP20K	UVH1RT20K	MUVH1RP20K	MUVH1RT20K
24 Vdc	UVH1RP21K	UVH1RT21K	MUVH1RP21K	MUVH1RT21K
48 Vdc	UVH1RP22K	UVH1RT22K	MUVH1RP22K	MUVH1RT22K
60 Vdc	UVH1RP22K	UVH1RT22K	MUVH1RP22K	MUVH1RT22K
110–127 Vdc	UVH1RP26K	UVH1RT26K	MUVH1RP26K	MUVH1RT26K
220–250 Vdc	UVH1RP28K	UVH1RT28K	MUVH1RP28K	MUVH1RT28K

**Notes**

- ① Not listed with Underwriters Laboratories, for field installation.
- ② Standard mounting location.
- ③ Not for use on right pole of four-pole circuit breaker.

## J-Frame and HMCP (J) Undervoltage Release Mechanism

Voltage Rating (AC Freq. = 50/60 Hz)	Factory Mounted Connection Type and Location			Field Mounted Field Installation Kits <sup>②</sup>		
	18-Inch (457.2 mm) Pigtail Leads			Terminal Block <sup>①</sup>	Pigtail Leads Catalog Number	Terminal Block <sup>③</sup> Catalog Number
	Same Side Suffix Number	Rear <sup>②</sup> Suffix Number	Opposite Side Suffix Number	Same Side Suffix Number		
<b>Left-Pole Mounting AC Ratings <sup>④</sup></b>						
12 Vac	U05	U06	U07	U08	UVH2LP02K	UVH2LT02K
24 Vac	U09	U10	U11	U12	UVH2LP03K	UVH2LT03K
48–60 Vac	U13	U14	U15	U16	UVH2LP05K	UVH2LT05K
110–127 Vac	U17	U18	U19	U20	UVH2LP08K	UVH2LT08K
208–240 Vac	U21	U22	U23	U24	UVH2LP11K	UVH2LT11K
380–480 Vac	U25	U26	U27	U28	UVH2LP15K	UVH2LT15K
<b>Right-Pole Mounting AC Ratings <sup>③</sup></b>						
12 Vac	U37	U38	U39	U40	UVH2RP02K	UVH2RT02K
24 Vac	U41	U42	U43	U44	UVH2RP03K	UVH2RT03K
48–60 Vac	U45	U46	U47	U48	UVH2RP05K	UVH2RT05K
110–127 Vac	U49	U50	U51	U52	UVH2RP08K	UVH2RT08K
208–240 Vac	U53	U54	U55	U56	UVH2RP11K	UVH2RT11K
380–480 Vac	U57	U58	U59	U60	UVH2RP15K	UVH2RT15K
<b>Left-Pole Mounting DC Ratings <sup>④</sup></b>						
12 Vdc	T01	T02	T03	T04	UVH2LP20K	UVH2LT20K
24 Vdc	T05	T06	T07	T08	UVH2LP21K	UVH2LT21K
48–60 Vdc	T09	T10	T11	T12	UVH2LP23K	UVH2LT23K
110–127 Vdc	T13	T14	T15	T16	UVH2LP26K	UVH2LT26K
220–250 Vdc	T17	T18	T19	T20	UVH2LP28K	UVH2LT28K
<b>Right-Pole Mounting DC Ratings <sup>③</sup></b>						
12 Vdc	T21	T22	T23	T24	UVH2RP20K	UVH2RT20K
24 Vdc	T25	T26	T27	T28	UVH2RP21K	UVH2RT21K
48–60 Vdc	T29	T30	T31	T32	UVH2RP23K	UVH2RT23K
110–127 Vdc	T33	T34	T35	T36	UVH2RP26K	UVH2RT26K
220–250 Vdc	T37	T38	T39	T40	UVH2RP28K	UVH2RT28K

**Notes**

- <sup>①</sup> For electrical rating data for manual, automatic and electrical reset undervoltage release mechanisms, refer to Eaton.  
<sup>②</sup> Listed with Underwriters Laboratories for field installation under E64983.  
<sup>③</sup> Not for use on right pole of four-pole circuit breakers.  
<sup>④</sup> Standard mounting location—leads exit rear of breaker.

## K-Frame and HMCP (K) Undervoltage Release Mechanism

Voltage Rating (AC Freq. = 50/60 Hz)	Factory Mounted Connection Type and Location				Field Mounted Field Installation Kits <sup>①</sup>	
	18-Inch (457.2 mm) Pigtail Leads			Terminal Block	Pigtail Leads Catalog Number	Terminal Block Catalog Number
	Same Side Suffix Number	Rear <sup>②</sup> Suffix Number	Opposite Side Suffix Number	Same Side Suffix Number		
<b>Left-Pole Mounting AC Ratings <sup>②</sup></b>						
12 Vac	U05	U06	U07	U08	UVH3LP02K	UVH3LT02K
24 Vac	U09	U10	U11	U12	UVH3LP03K	UVH3LT03K
48–60 Vac	U13	U14	U15	U16	UVH3LP05K	UVH3LT05K
110–127 Vac	U17	U18	U19	U20	UVH3LP08K	UVH3LT08K
208–240 Vac	U21	U22	U23	U24	UVH3LP11K	UVH3LT11K
380–480 Vac	U25	U26	U27	U28	UVH3LP15K	UVH3LT15K
<b>Right-Pole Mounting AC Ratings <sup>③④⑤</sup></b>						
12 Vac	U37	U38	U39	U40	UVH3RP02K	UVH3RT02K
24 Vac	U41	U42	U43	U44	UVH3RP03K	UVH3RT03K
48–60 Vac	U45	U46	U47	U48	UVH3RP05K	UVH3RT05K
110–127 Vac	U49	U50	U51	U52	UVH3RP08K	UVH3RT08K
208–240 Vac	U53	U54	U55	U56	UVH3RP11K	UVH3RT11K
380–480 Vac	U57	U58	U59	U60	UVH3RP15K	UVH3RT15K
<b>Left-Pole Mounting DC Ratings <sup>②</sup></b>						
12 Vdc	T01	T02	T03	T04	UVH3LP20K	UVH3LT20K
24 Vdc	T05	T06	T07	T08	UVH3LP21K	UVH3LT21K
48–60 Vdc	T09	T10	T11	T12	UVH3LP23K	UVH3LT23K
110–127 Vdc	T13	T14	T15	T16	UVH3LP26K	UVH3LT26K
220–250 Vdc	T17	T18	T19	T20	UVH3LP28K	UVH3LT28K
<b>Right-Pole Mounting DC Ratings <sup>③④⑤</sup></b>						
12 Vdc	T21	T22	T23	T24	UVH3RP20K	UVH3RT20K
24 Vdc	T25	T26	T27	T28	UVH3RP21K	UVH3RT21K
48–60 Vdc	T29	T30	T31	T32	UVH3RP23K	UVH3RT23K
110–127 Vdc	T33	T34	T35	T36	UVH3RP26K	UVH3RT26K
220–250 Vdc	T37	T38	T39	T40	UVH3RP28K	UVH3RT28K

**Notes**

- ① Listed with Underwriters Laboratories, for field installation under E64983.
- ② Standard mounting location—leads exit rear of breaker.
- ③ For use with KT (thermal-magnetic) trip units only.
- ④ Not for use on right pole of four-pole circuit breaker.
- ⑤ Breakers with K-Frame OPTIM 550 can only accept accessories in left pole.

## L-, HMCP (L) and (M)-Frames and Undervoltage Release Mechanism

Voltage Rating (AC Freq. = 50/60 Hz)	Factory Mounted Connection Type and Location				Field Mounted Field Installation Kits <sup>①</sup>	
	18-Inch (457.2 mm) Pigtail Leads			Terminal Block	Pigtail Leads Catalog Number	Terminal Block Catalog Number
	Same Side Suffix Number	Rear <sup>②</sup> Suffix Number	Opposite Side Suffix Number	Same Side Suffix Number		
<b>Left-Pole Mounting AC Ratings <sup>②</sup></b>						
12 Vac	U05	U06	U07	U08	UVH4LP02K	UVH4LT02K
24 Vac	U09	U10	U11	U12	UVH4LP03K	UVH4LT03K
48–60 Vac	U13	U14	U15	U16	UVH4LP05K	UVH4LT05K
110–127 Vac	U17	U18	U19	U20	UVH4LP08K	UVH4LT08K
208–240 Vac	U21	U22	U23	U24	UVH4LP11K	UVH4LT11K
380–480 Vac	U25	U26	U27	U28	UVH4LP15K	UVH4LT15K
<b>Right-Pole Mounting AC Ratings <sup>③④</sup></b>						
12 Vac	U37	U38	U39	U40	UVH4RP02K	UVH4RT02K
24 Vac	U41	U42	U43	U44	UVH4RP03K	UVH4RT03K
48–60 Vac	U45	U46	U47	U48	UVH4RP05K	UVH4RT05K
110–127 Vac	U49	U50	U51	U52	UVH4RP08K	UVH4RT08K
208–240 Vac	U53	U54	U55	U56	UVH4RP11K	UVH4RT11K
380–480 Vac	U57	U58	U59	U60	UVH4RP15K	UVH4RT15K
<b>Left-Pole Mounting DC Ratings <sup>②</sup></b>						
12 Vdc	T01	T02	T03	T04	UVH4LP20K	UVH4LT20K
24 Vdc	T05	T06	T07	T08	UVH4LP21K	UVH4LT21K
48–60 Vdc	T09	T10	T11	T12	UVH4LP23K	UVH4LT23K
110–127 Vdc	T13	T14	T15	T16	UVH4LP26K	UVH4LT26K
220–250 Vdc	T17	T18	T19	T20	UVH4LP28K	UVH4LT28K
<b>Right-Pole Mounting DC Ratings <sup>③④</sup></b>						
12 Vdc	T21	T22	T23	T24	UVH4RP20K	UVH4RT20K
24 Vdc	T25	T26	T27	T28	UVH4RP21K	UVH4RT21K
48–60 Vdc	T29	T30	T31	T32	UVH4RP23K	UVH4RT23K
110–127 Vdc	T33	T34	T35	T36	UVH4RP26K	UVH4RT26K
220–250 Vdc	T37	T38	T39	T40	UVH4RP28K	UVH4RT28K

**Notes**

- ① Listed with Underwriters Laboratories for field installation under E64983.  
 ② Standard mounting location—leads exit rear of breaker.  
 ③ For use with LT (thermal-magnetic) trip units only.  
 ④ Not for use on right pole of four-pole circuit breaker.

## N-Frame and HMCP (N) Undervoltage Release Mechanism

Voltage Rating (AC Freq. = 50/60 Hz)	Factory Mounted Connection Type and Location 18-Inch (457.2 mm) Pigtail Leads				Field Mounted Field Installation Kits <sup>①</sup>	
	Terminal Block			Same Side Suffix Number	Pigtail Leads Catalog Number	Terminal Block Catalog Number
	Same Side	Rear <sup>②</sup>	Opposite Side			
	Suffix Number	Suffix Number	Suffix Number			
<b>Left-Pole Mounting AC Ratings <sup>②</sup></b>						
12 Vac	U05	U06	U07	U08	UVH5LP02K	UVH5LT02K
24 Vac	U09	U10	U11	U12	UVH5LP03K	UVH5LT03K
48–60 Vac	U13	U14	U15	U16	UVH5LP05K	UVH5LT05K
110–127 Vac	U17	U18	U19	U20	UVH5LP08K	UVH5LT08K
208–240 Vac	U21	U22	U23	U24	UVH5LP11K	UVH5LT11K
380–480 Vac	U25	U26	U27	U28	UVH5LP29K	UVH5LT29K
<b>Left-Pole Mounting DC Ratings <sup>②</sup></b>						
12 Vdc	T01	T02	T03	T04	UVH5LP20K	UVH5LT20K
24 Vdc	T05	T06	T07	T08	UVH5LP21K	UVH5LT21K
48–60 Vdc	T09	T10	T11	T12	UVH5LP23K	UVH5LT23K
110–127 Vdc	T13	T14	T15	T16	UVH5LP26K	UVH5LT26K
220–250 Vdc	T17	T18	T19	T20	UVH5LP28K	UVH5LT28K

## R-Frame Undervoltage Release Mechanism (RH only)

Voltage Rating (AC Frequency = 50/60 Hz)	Factory Mounted Connection Type and Location 18-Inch (457.2 mm) Pigtail Leads	Field Mounted Field Installation Kits <sup>③</sup>
	Suffix Number <sup>④</sup>	Pigtail Leads Catalog Number <sup>④</sup>
	12 Vac	U37
24 Vac	U41	UVH6RP03K
48–60 Vac	U45	UVH6RP05K
110–127 Vac	U49	UVH6RP08K
208–240 Vac	U53	UVH6RP11K
380–500 Vac	U57	UVH6RP29K
12 Vdc	T21	UVH6RP20K
24 Vdc	T25	UVH6RP21K
48–60 Vdc	T29	UVH6RP23K
110–125 Vdc	T33	UVH6RP26K
220–250 Vdc	T37	UVH6RP28K

**Notes**

- ① Listed with Underwriters Laboratories for field installation under E64983.  
 ② Standard mounting location—leads exit rear of breaker.  
 ③ Endurance: 500 electrical operations plus 2500 mechanical operations.  
 ④ Pigtail wire size: 18 AWG (0.82 mm<sup>2</sup>). Leads are orange and brown.

**Accessory Terminal Block (R-Frame)****Accessory Terminal Block (R-Frame)****R-Frame Accessory Terminal Block** <sup>①</sup>

Factory Installed Suffix Number	Field Mounted Catalog Number
---------------------------------------	------------------------------------

Q01	TBRDK
-----	-------

**Number of Control Wires for Each Internally Mounted Accessory**

Type of Accessory	Number of Contacts per Single Accessory	Required Number of Wires
Auxiliary switch	2a/2b 4a/4b	6 12
Alarm (Signal)/ Lockout switch	1m/1b 2m/2b	6 12
Shunt trip	N/A	2
Low energy shunt	N/A	2
Undervoltage release mechanism	N/A	2

**PowerNet and Zone Interlock Kits (OPTIM 550 Only)  
K-, L- and N-Frames****PowerNet and Zone  
Interlock Kits****PowerNet Interlock Kit** <sup>②</sup>

Circuit Breaker	Factory Install Suffix	Catalog Number
K-Frame	PN	ICK550K
L-Frame	PN	ICK550L
N-Frame	PN	ICK550N

**Zone Interlock/Ground Kit** <sup>②③</sup>

Circuit Breaker	Factory Install Suffix	Catalog Number
K-Frame	ZG	ZGK550K
L-Frame	ZG	ZGK550L
N-Frame	ZG	ZGK550N

**PowerNet and Zone Interlock/Ground Kit** <sup>②③</sup>

Circuit Breaker	Factory Install Suffix	Catalog Number
K-Frame	ZGP	ZGPK550K
L-Frame	ZGP	ZGPK550L
N-Frame	ZGP	ZGPK550N

**Notes**

- ① One 24-point accessory terminal block provided with circuit breaker when ordered factory installed or shipped from warehouse as separate item when ordered for field installation. See Digitrip RMS master connection diagram (IL 29C714).
- ② Installation of these kits restrict any other attachments from being installed in the RH pole.
- ③ Includes a ground fault alarm signal that can drive the ground fault alarm unit (catalog number GFAU).

## Technical Data and Specifications

2

### Alarm Switch

#### F-Frame Electrical Rating Data <sup>①②</sup>

Maximum Voltage	Frequency	Maximum Current Amperes	Dielectric Withstand Voltage
<b>Multi-Pole Circuit Breakers</b>			
600	50/60 Hz	6	2500
125	DC	0.50 <sup>③</sup>	2500
250	DC	0.25 <sup>③</sup>	2500
<b>Single-Pole Circuit Breakers</b>			
125/250	50/60 Hz	6 <sup>④</sup>	2000
28	DC	3 <sup>④</sup>	2000
28	DC	5 <sup>④</sup>	2000

#### J-Frame Electrical Rating Data <sup>⑤⑥</sup>

Maximum Voltage	Frequency	Maximum Current Amperes	Dielectric Withstand Voltage
600	50/60 Hz	6	2500
125	DC	0.50 <sup>③</sup>	2500
250	DC	0.25 <sup>③</sup>	2500

#### K-Frame Electrical Rating Data <sup>⑥⑦</sup>

Maximum Voltage	Frequency	Maximum Current Amperes	Dielectric Withstand Voltage
600	50/60 Hz	6	2500
125	DC	0.50 <sup>③</sup>	2500
250	DC	0.25 <sup>③</sup>	2500

#### L- and M-Frames Electrical Rating Data <sup>⑥⑦</sup>

Maximum Voltage	Frequency	Maximum Current Amperes	Dielectric Withstand Voltage
600	50/60 Hz	6	2500
125	DC	0.50 <sup>③</sup>	2500
250	DC	0.25 <sup>③</sup>	2500

#### N-Frame Electrical Rating Data <sup>⑧</sup>

Maximum Voltage	Frequency	Maximum Current Amperes	Dielectric Withstand Voltage
600	50/60 Hz	6	2500
125	DC	0.50 <sup>③</sup>	2500
250	DC	0.25 <sup>③</sup>	2500

#### R-Frame Electrical Rating Data <sup>⑧⑩</sup>

Maximum Voltage	Frequency	Maximum Current Amperes	Dielectric Withstand Voltage
600	50/60 Hz	6	2500
125	DC	0.50 <sup>③</sup>	2500
250	DC	0.25 <sup>③</sup>	2500

#### Notes

- ① Endurance: 6000 electrical operations plus 4000 mechanical operations.
- ② Endurance: 6000 electrical operations plus 2000 mechanical operations.
- ③ Non-inductive load.
- ④ Inductive (L/R = 0.026).
- ⑤ Endurance: 6000 electrical operations plus 2000 mechanical operations.
- ⑥ Pigtail wire size: 18 AWG (0.82 mm<sup>2</sup>).
- ⑦ Endurance: 5000 electrical operations plus 1000 mechanical operations.
- ⑧ Endurance: 3000 electrical operations plus 1000 mechanical operations.
- ⑨ Endurance: 500 electrical operations plus 2500 mechanical operations.
- ⑩ Pigtail wire size: 18 AWG (0.82 mm<sup>2</sup>). Leads are red, black and blue.

**Auxiliary Switch****F-Frame Electrical Rating Data** <sup>①②</sup>

Maximum Voltage	Frequency	Maximum Current Amperes	Dielectric Withstand Voltage
125 <sup>③</sup>	50/60 Hz	1	2500
600	50/60 Hz	6	2500
125	DC	0.50 <sup>④</sup>	2500
250	DC	0.25 <sup>④</sup>	2500

**J-Frame Electrical Rating Data** <sup>①②</sup>

Maximum Voltage	Frequency	Maximum Current Amperes	Dielectric Withstand Voltage
600	50/60 Hz	6	2500
125	DC	0.50 <sup>④</sup>	2500
250	DC	0.25 <sup>④</sup>	2500

**K-Frame Electrical Rating Data** <sup>②⑤</sup>

Maximum Voltage	Frequency	Maximum Current Amperes	Dielectric Withstand Voltage
600	50/60 Hz	6	2500
125	DC	0.50 <sup>④</sup>	2500
250	DC	0.25 <sup>④</sup>	2500

**L- and M-Frames Electrical Rating Data** <sup>②</sup>

Maximum Voltage	Frequency	Maximum Current Amperes	Dielectric Withstand Voltage
600	50/60 Hz	6	2500
125	DC	0.50 <sup>④</sup>	2500
250	DC	0.25 <sup>④</sup>	2500

**N-Frame Electrical Rating Data** <sup>②⑥</sup>

Maximum Voltage	Frequency	Maximum Current Amperes	Dielectric Withstand Voltage
600	50/60 Hz	6	2500
125	DC	0.50 <sup>④</sup>	2500
250	DC	0.25 <sup>④</sup>	2500

**R-Frame Electrical Rating Data** <sup>⑦⑧</sup>

Maximum Voltage	Frequency	Maximum Current Amperes
600	50/60 Hz	6
125	DC	0.50 <sup>④</sup>
250	DC	0.25 <sup>④</sup>

**Notes**

- ① Endurance: 6000 electrical operations plus 4000 mechanical operations.
- ② Pigtail wire size: 18 AWG (0.82 mm<sup>2</sup>).
- ③ For use in electronic circuit of 100 micro amperes and 15 Vdc minimum.
- ④ Non-inductive load.
- ⑤ Endurance: 5000 electrical operations plus 1000 mechanical operations.
- ⑥ Endurance: 3000 electrical operations plus 1000 mechanical operations.
- ⑦ Endurance: 500 electrical operations plus 2500 mechanical operations.
- ⑧ Pigtail wire size: 18 AWG (0.82 mm<sup>2</sup>). Leads are red, black and blue.

**Auxiliary Switch and Alarm Switch Combination**

2

**F-Frame Electrical Rating Data** <sup>①②</sup>

Maximum Voltage	Frequency	Maximum Current Amperes	Dielectric Withstand Voltage
600	50/60 Hz	6	2500
125	DC	0.50 <sup>③</sup>	2200
250	DC	0.25 <sup>③</sup>	2200

**J-Frame Electrical Rating Data** <sup>②④</sup>

Maximum Voltage	Frequency	Maximum Current Amperes	Dielectric Withstand Voltage
600	50/60 Hz	6	2500
125	DC	0.50 <sup>③</sup>	2500
250	DC	0.25 <sup>③</sup>	2500

**K-Frame Electrical Rating Data** <sup>②⑤</sup>

Maximum Voltage	Frequency	Maximum Current Amperes	Dielectric Withstand Voltage
600	50/60 Hz	6	2500
125	DC	0.50 <sup>③</sup>	2500
250	DC	0.25 <sup>③</sup>	2500

**L- and M-Frames Electrical Rating Data** <sup>②⑤</sup>

Maximum Voltage	Frequency	Maximum Current Amperes	Dielectric Withstand Voltage
600	50/60 Hz	6	2500
125	DC	0.50 <sup>③</sup>	2500
250	DC	0.25 <sup>③</sup>	2500

**N-Frame Electrical Rating Data** <sup>②⑥</sup>

Maximum Voltage	Frequency	Maximum Current Amperes	Dielectric Withstand Voltage
600	50/60 Hz	6	2500
125	DC	0.50 <sup>③</sup>	2500
250	DC	0.25 <sup>③</sup>	2500

**Notes**

- ① Endurance: 6000 electrical operations plus 4000 mechanical operations.
- ② Pigtail wire size: 18 AWG (0.82 mm<sup>2</sup>).
- ③ Non-inductive load.
- ④ Endurance: 6000 electrical operations plus 2000 mechanical operations.
- ⑤ Endurance: 5000 electrical operations plus 1000 mechanical operations.
- ⑥ Endurance: 3000 electrical operations plus 1000 mechanical operations.

**Shunt Trip****F-Frame Electrical Rating Data** ①②③

50/60 Hz			DC		
Supply Voltage	Minimum Operating Voltage	VA	Supply Voltage	Minimum Operating Voltage	VA
12	6.3	75	12	8.4	100
24	6.3	300	24	8.4	400
48	33.6	92	48	33.6	100
60	33.6	140	60	33.6	160
110	33.6	480	110	77	55
120	33.6	570	120	77	66
127	33.6	640	125	77	71
208	146	180	—	—	—
220	146	200	—	—	—
240	146	240	—	—	—
380	146	610	127	—	72
415	280	330	220	154	110
440	280	380	250	154	140
480	280	350	—	—	—
525	280	530	—	—	—
550	280	590	—	—	—
600	280	700	—	—	—

**J-Frame Electrical Rating Data** ①②④

50/60 Hz			DC		
Supply Voltage	Minimum Operating Voltage	VA	Supply Voltage	Minimum Operating Voltage	VA
12	9	31	12	8.4	50
24	9	173	24	8.4	247
48	36	686	48	33.6	1094
60	36	1014	60	33.6	1698
110 <sup>⑤</sup>	60.5	66	110	77	112
120 <sup>⑤</sup>	60.5	84	120	77	138
127 <sup>⑤</sup>	60.5	102	125	77	150
208 <sup>⑤</sup>	60.5	354	—	77	—
220 <sup>⑤</sup>	60.5	396	—	—	—
240 <sup>⑤</sup>	60.5	432	—	—	—
380	285	180	110	154	40
400	285	200	120	154	58
415	285	240	125	154	—
440	285	610	127	154	—
480	360	34	—	—	—
525	360	42	—	—	—
550	360	50	—	—	—
600	360	60	—	—	—

**K-Frame Electrical Rating Data** ⑥⑦⑧

50/60 Hz			DC		
Supply Voltage	Minimum Operating Voltage	VA	Supply Voltage	Minimum Operating Voltage	VA
12	9	45	12	8.4	35
24	9	200	24	8.4	170
48	—	830	48	—	710
60	—	1280	60	—	1105
110 <sup>⑥</sup>	60	100	110	77	110
120 <sup>⑥</sup>	60	120	120	77	130
127 <sup>⑥</sup>	60	140	125	77	140
208 <sup>⑥</sup>	60	420	—	—	—
220 <sup>⑥</sup>	60	470	—	—	—
240 <sup>⑥</sup>	60	550	—	—	—
380	285	95	220	154	41
400	285	108	250	154	54
415	285	120	—	154	—
440	285	136	—	154	—
480	360	40	—	—	—
525	360	50	—	—	—
550	360	50	—	—	—
600	360	70	—	—	—

**Notes**

- ① Average unlatching time: 6 milliseconds.
- ② Average circuit breaker contact total opening time: 18 milliseconds.
- ③ Endurance: 6000 electrical operations plus 4000 mechanical operations.
- ④ Endurance: 6000 electrical operations plus 2000 mechanical operations.
- ⑤ Supply voltages suitable for use with Class 1 GFP devices. Marking label included with accessory kits.
- ⑥ Approximate unlatching time: 6 milliseconds.
- ⑦ Approximate total circuit breaker contact opening time: 8 milliseconds.
- ⑧ Endurance: 5000 electrical operations plus 1000 mechanical operations.

# 2.3

## Molded Case Circuit Breakers

### Series C

2

#### L- and M-Frame Electrical Rating Data <sup>①②③</sup>

50/60 Hz			DC		
Supply Voltage	Minimum Operating Voltage	VA	Supply Voltage	Minimum Operating Voltage	VA
12	9	45	12	9	35
24	9	200	24	9	170
48	34	830	48	34	710
60	34	1280	60	34	1105
110 <sup>④</sup>	60	100	110	77	110
120 <sup>④</sup>	60	120	120	77	130
127 <sup>④</sup>	60	140	125	77	140
208 <sup>④</sup>	60	420	—	77	—
220 <sup>④</sup>	60	470	—	—	—
240 <sup>④</sup>	60	550	—	—	—
380	266	95	220	154	41
400	266	108	250	—	54
415	266	120	—	—	—
440	266	136	—	—	—
480	336	40	—	—	—
525	336	50	—	—	—
550	336	50	—	—	—
600	336	70	—	—	—

#### N-Frame Electrical Rating Data <sup>①②⑤</sup>

50/60 Hz			DC		
Supply Voltage	Minimum Operating Voltage	VA	Supply Voltage	Minimum Operating Voltage	VA
24	16.8	200	24	16.8	170
48	33.6	830	48	33.6	710
60	33.6	1280	60	33.6	1150
110 <sup>④</sup>	60	100	110	77	110
120 <sup>④</sup>	60	120	120	77	130
127 <sup>④</sup>	60	140	125	77	140
208 <sup>④</sup>	60	420	—	—	—
220 <sup>④</sup>	60	470	—	—	—
240 <sup>④</sup>	60	550	—	—	—
380	266	95	220	154	41
400	266	108	250	—	54
415	266	120	—	—	—
440	266	136	—	—	—
480	336	40	—	—	—
525	336	50	—	—	—
550	336	50	—	—	—
600	336	70	—	—	—

**Notes**

- ① Approximate unlatching time: 6 milliseconds.
- ② Approximate total circuit breaker contact opening time: 18 milliseconds.
- ③ Endurance: 5000 electrical operations plus 1000 mechanical operations.
- ④ Supply voltages suitable for use with Class 1 GFP devices. Marking label included with accessory kits.
- ⑤ Endurance: 3000 electrical operations plus 1000 mechanical operations.

## R-Frame Electrical Rating Data ①②③④⑤⑥

Suffix Number	Application Ratings		Electrical Operating Ratings					VA	One Minute Dielectric Withstand Voltage (V)
	Voltage (V)	Frequency (Hz)	Supply Voltage (V)	Minimum Operating Voltage (V)	I <sub>p</sub> (A)	I <sub>rms</sub> at 0.250s (A)	I <sub>rms</sub> at 0.033s (A)		
03/03K	24	50/60	24	16.8	36.1	—	25.5	612	1050
	24	DC	24	16.8	36.1	16.5	—	396	1050
05/05K	48–60	50/60	48	34.0	13.1	—	9.2	450	1120
	48–60	50/60	60	34.0	17.2	—	12.2	740	1120
11/11K ③	110–240	50/60	110	60.5	4.2	—	3.0	330	1480
	110–240	50/60	120	60.5	4.5	—	3.2	390	1480
	110–240	50/60	127	60.5	4.6	—	3.3	430	1480
	110–240	50/60	208	60.5	7.9	—	5.6	1170	1480
	110–240	50/60	220	60.5	8.5	—	6.0	1370	1480
	110–240	50/60	240	60.5	8.7	—	6.1	1470	1480
14/14K	380–440	50/60	380	266.0	4.5	—	3.2	1220	1880
	380–440	50/60	415	266.0	5.0	—	3.6	1500	1880
	380–440	50/60	440	266.0	5.3	—	3.7	1640	1880
	220–250	DC	220	154.0	—	2.4	—	530	1500
	220–250	DC	250	154.0	—	2.7	—	680	1500
18/18K	480–600	50/60	480	336.0	0.6	—	0.4	200	2200
	480–600	50/60	525	336.0	0.7	—	0.5	270	2200
	480–600	50/60	550	336.0	0.7	—	0.5	280	2200
	480–600	50/60	600	336.0	0.8	—	0.6	360	2200
23/23K	48–60	DC	48	34.0	—	9.8	—	470	1120
	48–60	DC	60	34.0	—	11.6	—	700	1120
26/26K	110–125	DC	110	77.0	—	3.3	—	370	1250
	110–125	DC	120	77.0	—	3.6	—	440	1250
	110–125	DC	125	77.0	—	3.8	—	480	1250

**Notes**

- ① Approximate unlatching time of 6 milliseconds.
- ② Average circuit breaker contact total opening time approximately 62 milliseconds, at rated voltage.
- ③ Endurance: 500 electrical operations and 2500 mechanical operations.
- ④ Shunt trip can be operated up to a maximum of six times per minute.
- ⑤ Maximum operating voltage—110% of maximum voltage range rating.
- ⑥ Pigtail wire size: 18 AWG (0.82 mm<sup>2</sup>). Leads are yellow and white.

**Undervoltage Release Mechanism**

2

**F-Frame Electrical Rating Data** <sup>①</sup>

50/60 Hz					DC				
Supply Voltage	Dropout Voltage		Pickup Voltage	VA	Supply Voltage	Dropout Voltage		Pickup Voltage	VA
	Minimum	Maximum	Maximum			Minimum	Maximum	Maximum	
12	4.2	6.3	7.6	1.3	12	4.2	8.4	10.2	2.8
12	4.2	6.3	7.6	2.5	12	4.2	8.4	10.2	2.8
24	8.4	16.8	20.4	1.4	24	8.4	16.8	20.4	1.6
48	21.0	33.6	40.8	1.2	48	21.0	33.6	40.8	1.3
60	21.0	33.6	40.8	1.9	60	21.0	33.6	40.8	2.0
110	44.5	77.0	93.5	1.3	110	44.5	77.0	93.5	1.5
120	44.5	77.0	93.5	1.5	120	44.5	77.0	93.5	1.7
127	44.5	77.0	93.5	1.7	125	44.5	77.0	93.5	1.9
208	84.0	145.6	176.8	2.2	220	87.5	154.0	187.0	2.6
220	84.0	145.6	176.8	2.4	250	87.5	154.0	187.0	3.4
240	84.0	145.6	176.8	2.9	—	—	—	—	—
380	168.0	266.0	323.0	2.9	—	—	—	—	—
415	168.0	266.0	323.0	3.5	—	—	—	—	—
440	168.0	266.0	323.0	3.9	—	—	—	—	—
480	168.0	266.0	323.0	4.6	—	—	—	—	—
525	210.0	367.0	446.0	4.3	—	—	—	—	—
550	210.0	367.0	446.0	4.8	—	—	—	—	—
600	210.0	367.0	446.0	5.8	—	—	—	—	—

**J-Frame Electrical Rating Data** <sup>②③</sup>

50/60 Hz					DC				
Supply Voltage	Dropout Voltage		Pickup Voltage	VA	Supply Voltage	Dropout Voltage		Pickup Voltage	VA
	Minimum	Maximum	Maximum			Minimum	Maximum	Maximum	
12	4.2	8.4	10.2	1.9	12	4.2	8.4	10.2	1.6
24	8.4	16.8	20.4	3.9	24	8.4	16.8	20.4	3.1
48	21.0	33.6	40.8	2.5	48	21.0	33.6	40.8	2.0
60	21.0	33.6	40.8	3.8	60	21.0	33.6	40.8	3.1
110	44.5	77.0	93.5	1.8	110	44.5	77.0	93.5	1.6
120	44.5	77.0	93.5	2.1	120	44.5	77.0	93.5	1.9
127	44.5	77.0	93.5	2.4	125	44.5	77.0	93.5	2.2
208	84.0	145.6	176.8	2.7	220	87.5	154.0	187.0	3.1
220	84.0	145.6	176.8	3.1	250	87.5	154.0	187.0	4.0
240	84.0	145.6	176.8	3.8	—	—	—	—	—
380	168.0	266.0	323.0	3.4	—	—	—	—	—
415	168.0	266.0	323.0	4.0	—	—	—	—	—
440	168.0	266.0	323.0	4.6	—	—	—	—	—
480	168.0	266.0	323.0	5.4	—	—	—	—	—

**Notes**

- ① Endurance: 6000 electrical operations plus 4000 mechanical operations.  
 ② Endurance: 6000 electrical operations plus 2000 mechanical operations.  
 ③ For electrical rating data for manual, automatic and electrical reset undervoltage release mechanisms, refer to Eaton.

**K-Frame Electrical Rating Data** ①

50/60 Hz					DC				
Supply Voltage	Dropout Voltage		Pickup Voltage	VA	Supply Voltage	Dropout Voltage		Pickup Voltage	VA
	Minimum	Maximum	Maximum			Minimum	Maximum	Maximum	
12	4.2	8.4	10.2	1.9	12	4.2	8.4	10.2	1.6
24	8.4	16.8	20.4	3.9	24	8.4	16.8	20.4	3.1
48	21.0	33.6	40.8	2.5	48	21.0	33.6	40.8	2.0
60	21.0	33.6	40.8	3.8	60	21.0	33.6	40.8	3.1
110	44.5	77.0	93.5	1.8	110	44.5	77.0	93.5	1.6
120	44.5	77.0	93.5	2.1	120	44.5	77.0	93.5	1.9
127	44.5	77.0	93.5	2.4	125	44.5	77.0	93.5	2.2
208	84.0	145.6	176.8	2.7	220	87.5	154.0	187.0	3.1
220	84.0	145.6	176.8	3.1	250	87.5	154.0	187.0	4.0
240	84.0	145.6	176.8	3.8	—	—	—	—	—
380	168.0	266.0	323.0	3.4	—	—	—	—	—
415	168.0	266.0	323.0	4.0	—	—	—	—	—
440	168.0	266.0	323.0	4.6	—	—	—	—	—
480	168.0	266.0	323.0	5.4	—	—	—	—	—

**L- and M-Frames Electrical Rating Data** ①

50/60 Hz					DC				
Supply Voltage	Dropout Voltage		Pickup Voltage	VA	Supply Voltage	Dropout Voltage		Pickup Voltage	VA
	Minimum	Maximum	Maximum			Minimum	Maximum	Maximum	
12	4.2	8.4	10.2	1.9	12	4.2	8.4	10.2	1.6
24	8.4	16.8	20.4	3.9	24	8.4	16.8	20.4	3.1
48	21.0	33.6	40.8	2.5	48	21.0	33.6	40.8	2.0
60	21.0	33.6	40.8	3.8	60	21.0	33.6	40.8	3.1
110	44.5	77.0	93.5	1.8	110	44.5	77.0	93.5	1.6
120	44.5	77.0	93.5	2.1	120	44.5	77.0	93.5	1.9
127	44.5	77.0	93.5	2.4	125	44.5	77.0	93.5	2.2
208	84.0	145.6	176.8	2.7	220	87.5	154.0	187.0	3.1
220	84.0	145.6	176.8	3.1	250	87.5	154.0	187.0	4.0
240	84.0	145.6	176.8	3.8	—	—	—	—	—
380	168.0	266.0	323.0	3.4	—	—	—	—	—
415	168.0	266.0	323.0	4.0	—	—	—	—	—
440	168.0	266.0	323.0	4.6	—	—	—	—	—
480	168.0	266.0	323.0	5.4	—	—	—	—	—

**Note**

① Endurance: 5000 electrical operations plus 1000 mechanical operations.

N-Frame Electrical Rating Data <sup>①</sup>

50/60 Hz					DC				
Supply Voltage	Dropout Voltage		Pickup Voltage	VA	Supply Voltage	Dropout Voltage		Pickup Voltage	VA
	Minimum	Maximum	Maximum			Minimum	Maximum	Maximum	
12	4.2	8.4	10.2	1.9	12	4.2	8.4	10.2	1.6
24	8.4	16.8	20.4	3.9	24	8.4	16.8	20.4	3.1
48	21.0	33.6	40.8	2.5	48	21.0	33.6	40.8	2.0
60	21.0	33.6	40.8	3.8	60	21.0	33.6	40.8	3.1
110	44.5	77.0	93.5	1.8	110	44.5	77.0	93.5	1.6
120	44.5	77.0	93.5	2.1	120	44.5	77.0	93.5	1.9
127	44.5	77.0	93.5	2.4	125	44.5	77.0	93.5	2.2
208	84.0	145.6	176.8	2.7	220	87.5	154.0	187.0	3.1
220	84.0	145.6	176.8	3.1	220	87.5	154.0	187.0	—
240	84.0	145.6	176.8	3.8	250	—	—	—	4.0
380	175.0	266.0	323.0	3.4	—	—	—	—	—
415	175.0	266.0	323.0	4.0	—	—	—	—	—
480	175.0	266.0	323.0	4.6	—	—	—	—	—
500	175.0	266.0	323.0	5.4	—	—	—	—	—

**Note**

<sup>①</sup> Endurance: 3000 electrical operations plus 1000 mechanical operations.

R-Frame AC Undervoltage Release Mechanism (Handle Reset) Ratings <sup>①②</sup>

Catalog Suffix	Application Ratings Voltage (V)	Electrical Operating Ratings			Approximate Operating Time (ms)				Maximum Circuit Breaker Contact Opening	Dielectric Withstand Voltage (V) <sup>⑤</sup>
		Supply Voltage (V)	Dropout Voltage (V)		Pickup Voltage (V) Max.	VA	Minimum UVR Response <sup>③</sup>	Initiation Circuit Breaker Contact Separation <sup>④</sup>		
02/02K	12	12	4.2	8.4	10.2	2.3	5	46	77	1024
03/03K	24	24	8.4	16.8	20.4	3.1	5	46	77	1048
05/05K	48–60	48	21.0	33.5	40.8	3.4	5	46	77	1120
		60	21.0	33.5	40.8	6.0	5	46	77	1120
08/08K	110–127	110	44.5	77.0	93.5	3.3	5	46	77	1254
		120	44.5	77.0	93.5	3.6	5	46	77	1254
		127	44.5	77.0	93.5	3.8	5	46	77	1254
11/11K	208–240	208	84.0	145.6	176.8	4.2	5	46	77	1480
		220	84.0	145.6	176.8	6.6	5	46	77	1480
		240	84.0	145.6	176.8	7.2	5	46	77	1480
29/29K	380–500	380	168.0	266.0	323.0	3.8	5	46	77	2000
		415	168.0	266.0	323.0	8.3	5	46	77	2000
		440	168.0	266.0	323.0	8.8	5	46	77	2000
		480	168.0	266.0	323.0	9.6	5	46	77	2000
		500	168.0	266.0	323.0	10.0	5	46	77	2000

R-Frame DC Undervoltage Release Mechanism (Handle Reset) Ratings <sup>①②</sup>

Catalog Suffix	Application Ratings Voltage (V)	Electrical Operating Ratings			Approximate Operating Time (ms)				Maximum Circuit Breaker Contact Opening	Dielectric Withstand Voltage (V) <sup>⑤</sup>
		Supply Voltage (V)	Dropout Voltage (V)		Pickup Voltage (V) Max.	VA	Minimum UVR Response <sup>③</sup>	Initiation Circuit Breaker Contact Separation <sup>④</sup>		
20/20K	12	12	4.2	8.4	10.2	3.4	5	46	77	1024
21/21K	24	24	8.4	16.8	20.4	4.3	5	46	77	1048
23/23K	48–60	48	21.0	33.5	40.8	4.8	5	46	77	1120
		60	21.0	33.5	40.8	7.2	5	46	77	1120
26/26K	110–127	110	43.8	77.0	93.5	3.3	5	46	77	1250
		120	43.8	77.0	93.5	3.6	5	46	77	1250
		125	43.8	77.0	93.5	3.8	5	46	77	1250
28/28K	220–250	220	87.5	154.0	187.0	6.6	5	46	77	1500
		250	87.5	154.0	187.0	7.5	5	46	77	1500

**Notes**

- ① Endurance: 500 electrical operations plus 2500 mechanical operations.  
 ② Pigtail wire size: 18 AWG (0.82 mm<sup>2</sup>). Leads are orange and brown.  
 ③ UVR will override a momentary voltage dip up to the response time shown.  
 ④ Unlatching occurs 1 millisecond before circuit breaker contacts begin to separate.  
 ⑤ For 1 minute.

### Series C External Accessories

2



## Contents

<i>Description</i>	<i>Page</i>
Product Overview . . . . .	V4-T2-116
Standards and Certifications . . . . .	V4-T2-117
Quick Reference . . . . .	V4-T2-118
G-Frame (15–100 Amperes) . . . . .	V4-T2-121
F-Frame (10–225 Amperes) . . . . .	V4-T2-135
J-Frame (70–250 Amperes) . . . . .	V4-T2-153
K-Frame (70–400 Amperes) . . . . .	V4-T2-161
L-Frame (125–600 Amperes) . . . . .	V4-T2-185
M-Frame (300–800 Amperes) . . . . .	V4-T2-211
N-Frame (400–1200 Amperes) . . . . .	V4-T2-222
R-Frame (800–2500 Amperes) . . . . .	V4-T2-237
Motor Circuit Protectors (MCP) . . . . .	V4-T2-256
Motor Protection Circuit Breakers (MPCB) . . . . .	V4-T2-267
Type ELC Current Limiter Attachment (Size 0–4) . . . . .	V4-T2-269
Current Limiting Circuit Breaker Module . . . . .	V4-T2-270
Internal Accessories . . . . .	V4-T2-273
External Accessories	
Product Selection . . . . .	V4-T2-308
Accessories . . . . .	V4-T2-326
Technical Data and Specifications . . . . .	V4-T2-327
Dimensions . . . . .	V4-T2-328

## External Accessories

### Product Overview

#### End Cap Kit

The end cap kit slides onto the line or load conductor of the circuit breaker and acts as a threaded adapter for the conductor to accept a ring terminal or other bolt-on connector. The end cap kit is available with English and metric thread sizes. (Field installation only.) Listed per UL File E7819.

#### Keeper Nut

The keeper nut slides onto the line or load conductor of the circuit breaker and acts as a threaded adapter for the conductor to accept a ring terminal or other bolt-on connector. The keeper nut is available with English and metric thread sizes. Screws and washers are supplied by customer. (Field installation only.) Listed per UL File E7819.

#### L-, M-, N-Frames

Not required. Terminals are threaded.

#### J-Frame Plug Nut

The plug nut is used in applications where screw-connected ring-type terminals are preferred to connect cables to circuit breaker conductors. The plug nut is press-fit into the opening in the circuit breaker terminal conductor. Screws and washers are supplied by customer.

#### Terminal Adapter

#### Control Wire Terminal Kit

The control wire terminal kit provides a means to tap off control power from a main disconnect, using the provided male end of a quick disconnect.

For use with steel or stainless steel terminals only.

**Note:** Terminal Kits contain one terminal for each pole and one terminal cover.

#### Multiwire Connectors

Eaton's field-installed multiwire connectors for the load side (OFF) end terminals are used to distribute the load from the circuit breaker to multiple devices without the use of separate distribution terminal blocks.

Multiwire lug kits include mounting hardware, insulators and tin-plated aluminum connectors to replace three mechanical load lugs. UL listed as used on the load side (OFF) end.

#### Terminal Shields

Terminal shields provide protection against accidental contact with live line side terminations. Terminal shields are fabricated from high dielectric insulating material and fasten over the front terminal access openings. Small openings in the shields provide limited access to the terminals for tightening connectors. (Field installation only.)

#### Rear Fed Terminals.

Rear fed terminals allow the cable to connect to the breaker from the back instead of the top. Terminal shields or interphase barriers are included with each rear fed terminal kit (depending on frame size). When catalog number starts with a 3, it indicates a kit with three terminals in each kit. Catalog number beginning with a TA indicates one terminal.

**Terminal End Covers**

The terminal end covers are designed for use in motor control center applications where, because of confined spaces, line side conductors are normally custom fitted. The molded end covers are made of high dielectric glass-polyester and slide over the line ends of the circuit breaker. Close fitting conductor openings are molded into the end covers. The end cover and circuit breaker case fit together to form terminal compartments that isolate discharged ionizing gases during circuit breaker tripping. Terminal end covers are available with two conductor opening diameters, 0.25-inch (6.4 mm) and 0.41-inch (10.4 mm), and are listed per UL File E7819. (Field installation only.)

**Interphase Barriers**

The interphase barriers provide additional electrical clearance between circuit breaker poles for special termination applications. The barriers are high dielectric insulating plates that are installed in the molded slots between the terminals. (Field installation only.) Two per package.

**Base Mounting Plate**

Suitable for mounting six single-pole circuit breakers.

**DIN Rail Adapter**

For use with standard 35 mm DIN rail such as, 35 x 7.5 or 35 x 15 mm per DIN EN50022.

Adapter mounting screws included are for use with two- and three-pole circuit breakers. Adapters for single-pole circuit breakers clip into the base molding.

**Key Operated Attachment****Lock Dog (Non-Padlockable)****Non-Padlockable Handle Block**

The non-padlockable handle block secures the circuit breaker handle in either the ON or OFF position. (Trip-free operation allows the circuit breaker to trip when the

handle block holds the circuit breaker handle in the ON position.) The device is positioned over the circuit breaker handle and secured by a setscrew to deter accidental operation of the circuit breaker handle. Listed per UL File E7819. (Field installation only.)

**Padlockable Handle****Padlockable Handle Lock**

The device is positioned in the cover opening to prevent handle movement. Will accommodate one 5/16-inch (8 mm) padlock.

**Snap-on Padlockable Handle Lock Hasp**

The snap-on padlockable handle lock allows the handle to be locked in the OFF or ON position. (Trip-free operation allows the circuit breaker to trip when the handle lock holds the circuit breaker handle in the ON position.) This device was designed for use on the single-pole circuit breaker, but may be used on one-, two-, three- and four-pole styles. The handle lock snaps onto the escutcheon area of the handle with an optional retaining screw for added secureness. The handle lock will accommodate one padlock with a 1/4-inch (6.4 mm) shackle. Listed per UL File E7819. (Field installation only.)

**Padlockable Handle Lock Hasp**

The padlockable handle lock hasp allows the handle to be locked in the ON or OFF position. (Trip-free operation allows the circuit breaker to trip when the handle lock holds the circuit breaker handle in the ON position.) The hasp mounts on the circuit breaker cover within the trimline. The cover is predrilled on both sides of the operating handle so that the hasp can be mounted on either side of the handle. The hasp will accommodate up to three padlocks with 1/4-inch (6.4 mm) shackles, one per circuit breaker. Listed per UL File E7819. (Field installation only.)

**Cylinder Lock**

The cylinder lock internally blocks the trip bar in the tripped position to prevent the circuit breaker from being switched to ON. The cylinder lock is factory installed in the left pole only of the circuit breaker cover. Other internally mounted accessories cannot be installed in the same pole as the cylinder lock. (Factory installation only.)

**Key Interlock Kit (Lock Not Included)**

The key interlock is used to externally lock the circuit breaker handle in the OFF position. When the key interlock is locked, an extended deadbolt blocks movement of the circuit breaker handle. Uniquely coded keys are removable only with the deadbolt extended. Each coded key controls a group of circuit breakers for a given specific customer installation.

The key interlock assembly is Underwriters Laboratories listed for field installation under UL File E7819 and consists of a mounting kit and a purchaser supplied deadbolt lock. The mounting kit comprises a mounting plate, which is secured to the circuit breaker cover in either the left- or right-pole position, key interlock mounting screws, and a wire seal. Specific mounting kits are required for individual key interlock types.

**Sliding Bar Interlock**

The sliding bar interlock provides mechanical interlocking between two adjacent three-pole circuit breakers. It is installed on the enclosure cover between the circuit breakers. When the sliding bar interlock handle is moved from one side to the other, a bar extends to alternately block movement of the circuit breaker handles and prevents both circuit breakers from being switched to ON at the same time. Sliding bar interlocks are not UL listed. (Field installation only.)

**Walking Beam Interlock**

The walking beam Interlock provides mechanical interlocking between two adjacent circuit breakers of the same pole configuration. The walking beam interlock mounts on a bracket behind and between the circuit breakers. A plunger on each end of the beam is inserted through an access hole in the back plate and base of each circuit breaker. The walking beam interlock prevents both circuit breakers from being switched ON at the same time. If a walking beam interlock is installed, the wiring troughs in the back of the circuit breaker case are blocked by the plungers and cannot be used for cross wiring. Factory modified circuit breakers are required for this application. UL File E38116.

**Electrical Operator**

The electrical (solenoid) operator is a single solenoid mechanism that enables local and remote circuit breaker ON, OFF, and reset switching. The electrical operator is mounted on the circuit breaker cover within the trimline of the circuit breaker. The electrical operator uses a unique bi-stable latch that allows the device to operate using one solenoid. The accessory provides high-speed switching with a maximum operating time of 5 cycles (80 mS), making it suitable for generator synchronizing applications.

Means are provided for remote electrical operation and for local manual operation. A special slide includes provisions for padlocking the circuit breaker handle in the OFF position. The slide will accept three padlock shackles with a maximum diameter of 1/4-inch (6.4 mm) each. An interlock electrically disconnects the solenoid when the electrical operator cover is removed. The rating data tables provide electrical rating data for the electrical (solenoid) operator.

The electrical (motor) operator allows the circuit's breaker to be opened, closed or reset remotely. It also has a lock-off capability and provisions for manual operation.

The electrical (motor) operator contains a reversible motor connected to a ball screw. The ball screw drives the circuit breaker handle. Limit switches and relays are used to control the motor.

#### **Plug-In Adapters**

Plug-in adapters simplify installation and front removal of circuit breakers. Individual line and load plug-in adapters are available for rear connection applications on two-, three-, and four-pole circuit breakers. Common mounting plates for line- and load-end adapters are available.

One plug-in adapter kit is required for line-end and one for load-end.

Plug-in adapters are UL approved unless otherwise noted.

#### **Rear Connecting Studs**

Rear connecting studs are available in several sizes to accommodate specific fixed-mounted circuit breaker applications.

Each rear connecting stud assembly consists of one stud and one tube. To maintain proper clearances between poles, select alternate long and short stud assemblies for circuit breakers with more than one pole. One assembly is required for line-end and one for load-end of each pole. Tubes must be ordered separately. Connecting studs are available only with English thread sizes.

**Note:** Not UL listed.

#### **Panelboard Connecting Straps**

Panelboard connecting straps are used to connect the circuit breaker terminals to the panelboard bus. The panelboard connecting straps are available with various ratings for outside and center poles. (Field installation only.)

Panelboard connecting straps are available to meet the needs of most standard panelboard applications. Style numbers for mounting brackets for CDP panelboard installations are also included.

**Note:** Not UL listed. Refer to panelboard manufacturer for compatibility.

#### **Type LFD Current Limiter**

The LFD current limiter is an accessory that bolts to the load end of a standard FDB or FD thermal-magnetic circuit breaker, providing 200,000 A interrupting capacity at up to 600 Vac. LFD current limiters for thermal-magnetic and electronic circuit breakers are listed with Underwriters Laboratories under File E47239.

#### **Ground Fault Alarm Unit**

The ground fault alarm unit is a remotely mounted device with a combination indicating light/test button that will light when the breaker trips or alarms on ground fault. The ground fault alarm unit requires a separate 120 Vac power source to power the light and the internal relay, which has 1NO and 1NC contacts for remote indication. The ground fault alarm unit can be panel mounted for ordering with an optional face mounting bracket. For use on Digitrip 310 only, K- through N-Frame.

#### **IQ Energy Sentinel**

The IQ Energy Sentinel is a highly accurate, microprocessor-based, breaker-mounted device designed to monitor power and energy readings. It represents an alternative to watt meters, watt-hour meters, and watt demand meters. Key advantages include savings in space, lower installation costs, and remote monitoring capability.

The IQ Energy Sentinel mounts on the load side of a Series C F-Frame (150 ampere) circuit breaker. It can be applied on three-phase, four-wire systems, or single-phase, three-wire systems with voltage connected through Phases A and C.

For more information, see Descriptive Bulletin 8178.

#### **Potential Transformer Module**

The potential transformer module is required for the Digitrip OPTIM 1050 to provide a voltage input to allow the trip unit to monitor power and energy as well as power factor. The potential transformer module is a 6 VA transformer with a primary voltage input of up to 600 volt line to line. Three 0.1 ampere fuses are provided on the primary of the transformer and can be used for isolation purposes during dielectric testing. The device is normally panel mounted and can feed up to 16 OPTIM trip units.

#### **Solid-State (Electronic) Portable Test Kit**

The solid-state (electronic) portable test kit provides verification of performance of all ratings of Digitrip 310 electronic trip units installed in circuit breakers while in service under varying load and/or phase imbalance. The test kit operates on 120-volt, 50/60 Hz power; it includes complete instructions and test times for testing long time, short time/instantaneous operation and optional ground fault operation of the circuit breaker.

**Breaker Interface Module (BIM)**

The Breaker Interface Module (BIM) is a panel mounted user interface device that is mounted on the front of an electrical assembly or at a remote location. The BIM is used to access, configure, test and display information for OPTIM trip units and other devices. The BIM consists of four display windows, eight function buttons, 18 LEDs, and a graphical time/current curve to provide breaker status, operational information, protection status and energy monitoring. A 24 Vdc power supply is required to provide power to the BIM. This is supplied by the switchboard builder to Eaton's specifications. The BIM is a member of Eaton's PowerNet family of communicating devices that connects OPTIM trip units, Digitrip RMS 810/910 trip units and energy sentinels as a subnetwork system. The BIM can also be connected to a main network via a PONI module to PowerNet software.

**Digitrip OPTIMizer**

The Digitrip OPTIMizer is a hand-held programmer that is used to access, configure, test and display information from OPTIM trip units. The OPTIMizer plugs into the front of an OPTIM trip unit via an eight-pin telephone jack and is powered by a nine-volt battery or the auxiliary power module. One highlighted feature is the "Copy" and "Download" commands.

Setting up multiple OPTIM trips can be finished in minutes and with no errors. An Auxiliary Power Module connection provides a trip test when control power is not present at the breaker. The OPTIMizer is supplied as a standard package to include the programmer, the eight-pin connection cord, battery and carrying case. The auxiliary power module is optional.

**Auxiliary Power Module**

The auxiliary power module is a power supply requiring 120 Vac input at 50 or 60 Hz that provides a 32 Vdc output. The auxiliary power module provides control power for testing an OPTIM trip unit when other means of control power is not available or for continuous OPTIMizer operation versus temporary with a battery. The auxiliary power module connects into the top of the Digitrip OPTIMizer via a keyed receptacle. The main application for the auxiliary power module would be for the testing of a standalone non-communicating OPTIM breaker that ordinarily would not have control power.

**Cause of Trip Display/Remote Mount Cause of Trip Display**

The Cause of Trip Display can be field-installed on any Digitrip RMS 310+ trip unit. The device provides breaker information through an LCD screen, such as cause of trip, phase current, ground current and low loads. The display is ideal for troubleshooting common trips such as ground fault, long delay, and instantaneous/short delay. The DIGIVIEW version will provide a local display at the breaker without additional wiring by connecting directly onto the trip unit. The DIGIVIEWR06 version has a 6 foot cable that allows users to mount the display on the outside of an enclosure door and connect to the trip unit that is contained inside the enclosure.

**Cause of Trip LED Module**

The Cause of Trip LED Module can be field-installed on any Digitrip RMS 310+ trip unit. The device provides a cause of trip indication via LED. The Cause of Trip LED Module connects directly onto the trip unit. When the breaker trips, the module indicates the cause of trip (long delay, short delay, instantaneous and ground) via LED indication. The module is reset after the breaker is reset.

**Note:** The OPTIMizer can work off of 32 Vdc control power, although 24 Vdc is the standard on OPTIM breakers.

#### Product Selection

2

#### Termination Hardware—End Cap Kit

##### End Cap Kit

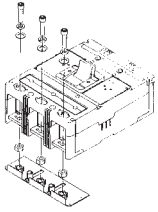

##### End Cap Kit

Thread Type	Thread Size	Catalog Number
<b>Two-Pole F-Frame (225A)</b>		
Imperial	10–32	KPEK12
Metric	M–5	KPEKM12
<b>Three-Pole F-Frame (225A)</b>		
Imperial	10–32	KPEK1
Metric	M–5	KPEKM1
<b>Four-Pole F-Frame (225A)</b>		
Imperial	10–32	KPEK14
Metric	M–5	KPEKM14
<b>Three-Pole J-Frame</b>		
Imperial	0.312–18	KPEK2
Metric	M–8	KPEKM2
<b>Four-Pole J-Frame</b>		
Imperial	0.312–18	KPEK24
Metric	M–8	KPEKM24
<b>Three-Pole K-Frame</b>		
Imperial	0.312–18	KPEK3
Metric	M–8	KPEKM3
<b>Four-Pole K-Frame</b>		
Imperial	0.312–18	KPEK34
Metric	M–8	KPEKM34
<b>Three-Pole L-Frame</b>		
Imperial	0.312–18	KPEK4
Metric	M–8	KPEKM4
<b>Four-Pole L-Frame</b>		
Imperial	0.312–18	KPEK44
Metric	M–8	KPEKM44

#### Termination Hardware—Keeper Nut

##### F-Frame Keeper Nut

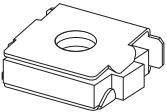

##### F-Frame Keeper Nut

Thread Type	Thread Size	Catalog Number Package of 12 (Priced Individually)
Imperial	10–32	KPR1A
Metric	M–5	KPR1AM

##### K-Frame Keeper Nut

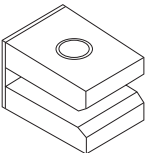

##### K-Frame Keeper Nut

Thread Type	Thread Size	Line/Load End	Catalog Number Package of 3
Imperial	0.375–16	Line	KPR3A
		Load	KPR3B
Metric	M–8	Line	KPR3AM
		Load	KPR3BM

**Note**

L-, M-, N-Frames not required. Terminals are threaded.

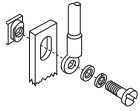
**Termination Hardware****J-Frame Plug Nut****J-Frame Plug Nut**

Thread Type	Thread Size	Catalog Number Package of 6
Imperial	0.250–20	PLN2
Metric	M–6	PLN2M

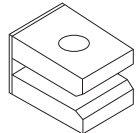
**K-Frame Terminal Adapter****K-Frame Terminal Adapter** <sup>①</sup>

Line/Load End	Catalog Number
Line and load	TAD3

**F-Frame Ordering Information**

Terminals must be ordered separately. Priced individually.

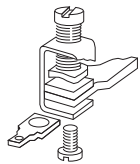
**F-Frame Kit****F-Frame Control Wire Terminal Kit** <sup>②</sup>

Description	Maximum Amperes	Catalog Number
Package of 12 control wire terminal tangs.	150	FCWTK
	225	FCWTK225

**J- and K-Frame Ordering Information**

Terminals must be ordered separately. Priced individually.

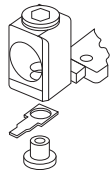
**J- and K-Frame Kit****J- and K-Frame Control Wire Terminal Kit**

Description	Catalog Number
Package of 12 control wire terminal tangs.	KCWTK

**L-Frame Control Wire Terminal Kit**

AWG Wire Range/Number Conductors	Metric Wire Range mm <sup>2</sup>	Catalog Number
Al/Cu 3/0–350 kcmil (2)	95–150	TA602LDCW <sup>③</sup>
Cu 250–350 kcmil (2)	120–250	T602LDCW <sup>③</sup>
Al/Cu 400–500 kcmil (2)	185–240	2TA603LDKCW <sup>④⑤</sup>
Al/Cu 400–500 kcmil (2)	185–240	3TA603LDKCW <sup>④⑥</sup>
Al/Cu 400–500 kcmil (2)	185–240	4TA603LDKCW <sup>④⑦</sup>

**Notes**

- ① K-Frame terminal adapter for use in replacing LB/DA breakers.
- ② Not for use with T250KB terminals.
- ③ Individually packed.
- ④ Terminal kits contain one terminal for each pole and one terminal cover.
- ⑤ Two-pole kit.
- ⑥ Three-pole kit.
- ⑦ Four-pole kit.

## Termination Hardware

2

## G-Frame Control Wire Terminal

Description	Catalog Number	Catalog Number
Control wire terminal (kit of 12)	5652B38G01	GCWTK

## Multiwire Connectors

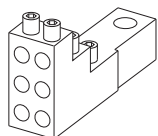

## Multiwire Connectors Ordering Information (Package of 3)

Maximum Amperes	Wires per Terminal	Wire Size Range AWG Cu	Kit Catalog Number <sup>①</sup>
<b>G-Frame <sup>②</sup></b>			
100	3	14–2	3TA100G3K
	6	14–6	3TA100G6K
<b>F-Frame</b>			
225	3	14–2	3TA150F3K
	6	14–6	3TA150F6K
<b>J-Frame</b>			
250	3	14–2	3TA250J3K
	6	14–6	3TA250J6K
<b>K-Frame</b>			
400	3	14–2/0	3TA400K3K
	6	14–3	3TA400K6K

## Rear Fed Terminals

Frame	Maximum Amperes	Wire Size Range AWG Cu	Catalog Number <sup>①</sup>
FD	150	14–4/0	TA150FDRF
	150	14–4/0	3TA150FDRF
	225	6–300 kcmil	TA225FDRF
	225	6–300 kcmil	3TA225FDRF
KD	400	250–500 kcmil	TA350KRF
	400	250–500 kcmil	3TA350KRF
MDL	800	3/0 MAX (3)	TA800MDLRF
	800	3/0 MAX (3)	3TA800MDLRF

## Base Mounting Hardware

## Ordering Information

Hardware for surface mounting of circuit breakers is supplied only on request. Hardware consists of mounting screws and lockwashers. Order hardware for circuit breaker pole configurations as required.

## Mounting Hardware

Screw Length in Inches (mm)	Catalog Number
<b>G-Frame</b>	
0.138–32 x 2.63 (3.5 x 66.7 mm) Std.	624B375G23
0.138–32 x 3.00 (3.5 x 76.2 mm)	8703C80G05

## Notes

- ① When catalog number starts with a 3, it indicates a kit with three terminals in each kit. Catalog number beginning with a TA indicates one terminal.
- ② GD breakers require special tapping for multiwire lugs, as described in the IL or use with standard aluminum collars.

## Imperial Thread Mounting Hardware

Number of Poles	Description	Type of Mounting	Catalog Number
<b>F-Frame</b>			
1	0.164-32 x 3.188-inch pan-head steel screws, lockwashers and clamps	Individual	<b>624B375G01</b>
		Group ①	<b>624B375G02</b>
2	0.164-32 x 1.5-inch pan-head steel screws and lockwashers	Individual	<b>4218B80G01</b>
3, 4	0.164-32 x 1.5-inch pan-head steel screws and lockwashers	Individual	<b>BMH1</b>
<b>J-Frame</b>			
2, 3, 4	0.250-20 x 2.75 inch pan-head steel screws and lockwashers	Individual	<b>BMH2</b>
<b>K-Frame</b>			
2, 3, 4	0.250-20 x 1.5 inch pan-head steel screws and lockwashers	Individual	<b>BMH3</b>
<b>L-Frame</b>			
2, 3, 4	0.250-20 x 1.5 inch filister-head steel screws and lockwashers and flat washers	Individual	<b>BMH4</b>
<b>M-Frame</b>			
2, 3	0.3125-18 x 1.25 inch filister-head steel screws and lockwashers and flat washers	Individual	<b>BMH5</b>
<b>N-Frame</b>			
2, 3, 4	0.3125-18 x 1.25 inch pan-head steel screws and lockwashers	Individual	<b>BMH5</b>
<b>R-Frame</b>			
Supplied by customer			

## Metric Thread Mounting Hardware

Number of Poles	Description	Type of Mounting	Catalog Number
<b>F-Frame</b>			
1	M4-0.7 x 80 mm pan-head steel screws, lockwashers, and clamps	Individual	<b>4218B80G09</b>
		Group ①	<b>4218B80G10</b>
2	M4-0.7 x 38 mm pan-head steel screws and lockwashers	Individual	<b>4218B80G11</b>
3, 4	M4-0.7 x 38 mm pan-head steel screws and lockwashers	Individual	<b>BMH1M</b>
<b>J-Frame</b>			
2, 3, 4	M6-0.7 x 70 mm pan-head steel screws and lockwashers	Individual	<b>BMH2M</b>
<b>K-Frame</b>			
2, 3, 4	M6-0.7 x 38 mm pan-head steel screws and lockwashers	Individual	<b>BMH3M</b>
<b>L-Frame</b>			
2, 3	—	Individual	<b>BMH4M</b>
<b>M-Frame</b>			
2, 3	—	Individual	<b>BMH5M</b>
<b>N-Frame</b>			
2, 3	—	Individual	<b>BMH5M</b>
<b>R-Frame</b>			
Supplied by customer			

**Note**

① One set of hardware for two circuit breakers.

#### Terminal Shields

2

#### G-Frame Terminal Shield

Number Units in Package	Catalog Number
10	GTSK3

#### F-Frame



#### F-Frame Terminal Shield

Number of Poles	Location	Standard (Package of 10) (Priced Individually)	Special—For Use When Electrical Operator is Mounted on Circuit Breaker
		Catalog Number	Catalog Number
1	Line	625B229G06	—
2	Line	625B229G07	—
3	Line	625B229G08	4210B95G01
4	Line	625B229G09	4210B95G02

#### J-Frame



#### J-Frame Terminal Shield

Number of Poles	Location	Catalog Number (Package of 10)
2, 3	Line End	1266C07G01
4	Line End	6631C01G01
2, 3	Load End	6641C16G01
4	Load End	6641C16G02

**K-Frame**



**K-Frame Terminal Shield**

Number of Poles	Location	Catalog Number (Package of 10)
2, 3	Line	TS33LN
4	Line	TS34LN
3	Load	TS33LD

**L-Frame Terminal Shield**

Catalog Number (Package of 1)
314C420G05

**M-Frame Terminal Shield**

Catalog Number (Package of 1)
208B966G01

**N-Frame Terminal Shield**

Catalog Number (Package of 1)
NTS3K

**Terminal End Covers**

**Ordering Information**

The terminal end cover is available for three-pole circuit breakers only. Two conductor opening sizes are available. Specify quantity (one per circuit breaker) when ordering.

**F-Frame**



**F-Frame Terminal End Covers**

Conductor Opening Diameter in Inches (mm)	Catalog Number
0.25 (6.35 mm)	TEC1
0.41 (10.41 mm)	TEC2

**Interphase Barriers**

**Ordering Information**

Two per package.

**Interphase Barrier**



**Interphase Barriers**

Frame	Catalog Number
F	IPB1
J, K	IPB3
L	IPB4
M	IPB4
N	IPB5

**Base Mounting Plate**

**Base Mounting Plate**



**Base Mounting Plate G-Frame GD/GHC**

Number of Units in Package	Catalog Number
1	207B513G01

**DIN Rail Adapter**

**DIN Rail Adapter**



**DIN Rail Adapter G-Frame GD/GHC**

Number of Poles	Number of Units in Package	Catalog Number
1, 2	10	1225C79G01
3	10	1225C79G02 ①

**All Metal DIN Rail Adapter G-Frame GD/GHC**

Number of Poles	Number of Units in Package	Catalog Number
3	1	EGGDIN

**Key Operated Attachment**

**Key Operated Attachment**

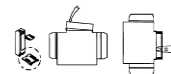

**Key Operated Attachment G-Frame GD/GHC**

Number of Units in Package	Catalog Number
10	GKOA

**Note**

① For use on three-pole breakers only.

# 2.3

## Molded Case Circuit Breakers

### Series C

2

#### Lock Dog (Non-Padlockable)

##### Lock Dog (Non-Padlockable)



##### Lock Dog (Non-Padlockable) G-Frame GD/GHC/GHB/GMCP

Number of Units in Package	Catalog Number
1	1294C01H01

#### Handle Ties

##### Handle Tie—Series C, F-Frame

Number of Poles	Number of Units in Package	Catalog Number
2	10	HTBFD2P
3	10	HTBFD3P

##### Handle Tie—Series C, G-Frame

Number of Poles	Number of Units in Package	Catalog Number
2	10	HTBGD2P
3	10	HTBGD3P

#### Non-Padlockable Handle Block

##### Non-Padlockable Handle Block



##### Non-Padlockable Handle Block

Frame	Catalog Number
F	LKD1
J, K	LKD3
L, M, N	LKD4

#### Padlockable Handle

##### Padlockable Handle



##### Padlockable G-Frame GD/GHC/GHB

Number of Units in Package	Catalog Number <sup>①</sup>
10	1223C77G03
10	1223C77G05 <sup>②</sup>
10	1223C77G06 <sup>②</sup>

#### Padlockable Handle Lock

##### Padlockable Handle Lock



##### Padlockable Handle Lock

Frame	Catalog Number
G	GPHBOFF
J, K	PHB3

#### Snap-On Padlockable Handle Lock Hasp

##### Snap-On Padlockable Handle Lock Hasp



##### Snap-On Padlockable Handle Lock Hasp

Frame	Catalog Number
F	PHL1

#### Notes

- ① Accepts 0.285 Lock Shank.
- ② Padlockable in the OFF position only.

**Padlockable Handle Lock Hasp****Padlockable Handle Lock Hasp****Padlockable Handle Lock Hasp**

Description	Catalog Number
<b>F-Frame</b>	
Single-pole breakers	PHL1
Two-, three- and four-pole breakers	PLK1
For left side mounting	PLK1LOFF
For right side mounting	PLK1ROFF
<b>J, K-Frames</b>	
Two-, three- and four-pole breakers	PLK3
For left side mounting	PLK3LOFF <sup>①</sup>
For right side mounting	PLK3ROFF <sup>①</sup>
<b>L-Frame (Side Mounted)</b>	
Lock ON or OFF	HLK4
Lock OFF only (left-hand mount)	HLK4LOFF <sup>①</sup>
<b>L-Frame (Top Mounted)</b>	
Lock ON or OFF	HLK4S
Lock OFF only	HLK4SOFF <sup>①</sup>
<b>M-Frame</b>	
Lock ON or OFF	HLK4
Lock OFF only (left-hand mount)	HLK4LOFF <sup>①</sup>
<b>M-Frame (Vertical Mounting)</b>	
Lock ON/OFF	HLK4S
Lock OFF only	HLK4SOFF
<b>N-Frame</b>	
Side mounted	PLK5
Top mounted (ON/OFF)	PLK5S
Top mounted (OFF only)	PLK5SOFF <sup>①</sup>
<b>R-Frame</b>	
Lock ON/OFF	HLK6
Lock OFF only	HLK6OFF <sup>①</sup>

**Cylinder Lock****Cylinder Lock****Cylinder Lock**

Frame	Catalog Number
F, J, K	Order by description

**Note**

- <sup>①</sup> For padlockable handle lock hasp to padlock handle in OFF position only, order either catalog number.

**Key Interlock Kit****Ordering Information**

Key interlock kits contain the necessary interface and hardware to install a trapped key interlock from one of the listed manufacturers. Key interlocks are not installed or supplied as part of the breaker, and must be obtained separately from the lock manufacturer or through the manufacturer of the equipment on which the breaker will be installed. Select the mounting kit catalog number to match the type of lock used.

**Key Interlock Kit****Key Interlock Kit (Trapped Key Interlock)**

Lock Manufacturer	Lock Type	Bolt Projection in Withdrawn Position in Inches (mm)	Kit Catalog Number
<b>F-Frame</b>			
Superior	B-4003-1	0.38 (9.5)	<b>KYK1</b>
Kirk®	F	0.38 (9.5)	<b>KYK1</b>
Castell ①	K or QK	0.38 (9.5)	<b>CTK1</b>
<b>J, K-Frames</b>			
Superior	B-4003-1	0.38 (9.5)	<b>KYK3</b>
Kirk	F	0.38 (9.5)	<b>KYK3</b>
Castell ①	K or QK	0.38 (9.5)	<b>CTK3</b>
<b>L-, M-, N-Frames</b>			
Superior	B-4003-1	0.38 (9.5)	<b>KYK4</b>
Kirk	F	0.38 (9.5)	<b>KYK4</b>
Castell ①	K or QK	0.38 (9.5)	<b>CTK4</b>
<b>R-Frame</b>			
Superior	B-4003-1	1.0 (25.4)	<b>KYK6</b>
Kirk	F	1.0 (25.4)	<b>KYK6</b>
Castell ①	K or QK	1.0 (25.4)	<b>CTK6</b>
<b>JG-Frame</b>			
Superior	B-4003-1	0.38 (9.5)	<b>KYKJG</b>
Kirk	F	0.38 (9.5)	<b>KYKJG</b>
Castell ①	K or QK	0.38 (9.5)	<b>CTKJG</b>
<b>LG-Frame</b>			
Superior	B-4003-1	0.38 (9.5)	<b>KYKLG</b>
Kirk	F	0.38 (9.5)	<b>KYKLG</b>
Castell ①	K or QK	0.38 (9.5)	<b>CTKLG</b>

**Note**

① When ordering Castell Interlock, it is necessary for customer to specify that the mounting bolt holes must be 10 mm in diameter

**Sliding Bar Interlock****Ordering Information**

The sliding bar interlock is available for mounting between two adjacent three-pole circuit breakers with circuit breakers centerline

spacing as indicated in table and enclosure front panel thickness of 1/8 or 3/16 inch (3.2 or 4.8 mm). (For field installation only.)

**Sliding Bar Interlock****Sliding Bar Interlock**

Frame	Centerline Spacing in Inches (mm)	Catalog Number
F	4.19 (106.4)	<b>SBK1</b>
J	4.38 (111.3)	<b>SBK2</b>
K	5.75 (146.0)	<b>SBK3</b>
L, M	8.50 (215.9)	<b>SBK4</b>
N	8.50 (215.9)	<b>SBK5</b>

**Walking Beam Interlock****Ordering Information**

The walking beam interlock is available for mounting between two adjacent circuit breakers spaced 1/4-inch (6.4 mm) apart and having the same pole configuration. The two circuit breakers must be factory modified to accept the walking beam interlock assembly (suitable for use with either two-, three- or four-pole circuit breakers).

With properly modified circuit breakers, the walking beam interlock is suitable for field installation. Order circuit breakers specifying modification for walking beam (20% price adder) and select walking beam interlock from table below. Circuit breakers and walking beam interlock are boxed and shipped separately.

**Walking Beam Interlock****Walking Beam Interlock**

Frame	Catalog Number
F	<b>WBL1</b>
K	<b>WBL3</b>
L, M	<b>WBL4A</b>
N	<b>WBL5</b>
R ①	<b>WBL6</b>

**Note**

① Three-pole only.

**Electrical Operator**

2

**F-Frame Electrical (Solenoid) Operator**

Voltage	Frequency	Terminal Block	18-Inch (457.2 mm) Pigtail Lead
		Catalog Number	Catalog Number
120	AC	EOP1T07	EOP1P07
240	AC	EOP1T11	EOP1P11

**F-Frame Electrical (Motor) Operator** <sup>①</sup>

Voltage	Frequency	18-Inch (457.2 mm) Pigtail Lead
		Catalog Number
120	50/60 Hz AC	MOPFD120C
24	DC	MOPFD24D
125	DC	MOPFD120C
208–240	50/60 Hz	MOPFD240C
220–250	DC	MOPFD240C

**J-Frame Electrical (Solenoid) Operator**

Operating Voltage	Frequency	Terminal Block
		Catalog Number
120	50/60 Hz AC	EOP2T07
240	50/60 Hz AC	EOP2T11

**K-Frame Electrical (Solenoid) Operator**

Operating Voltage	Frequency	Terminal Block
		Catalog Number
120	50/60 Hz AC	EOP3MT07
240	50/60 Hz AC	EOP3MT11

**K-Frame Electrical (Solenoid) Operator Base Mounting Kit**

Frame	Catalog Number
K	BBMK3

**L- and M-Frame Electrical (Motor) Operator (310 and OPTIM)**

Operating Voltage	Frequency	Terminal Block
		Catalog Number
120	50/60 Hz	EOP4MT07
208	50/60 Hz	EOP4MT11
240	50/60 Hz	EOP4MT11A
480	50/60 Hz	EOP4MT15
125	DC	EOP4MT26
24	DC	EOP4MT21

**Note**

<sup>①</sup> Motor operators MOP1P07, MOP1P03DC, MOP1P05DC and MOP1P07DC are replaced by MOPFD motor operators listed in table.

**N-Frame Electrical (Motor) Operator**

Operating Voltage	Frequency	Pigtail Leads
		Catalog Number
120	50/60 Hz	<b>EOP5T07</b>
208	50/60 Hz	<b>EOP5T09</b>
240	50/60 Hz	<b>EOP5T11</b>
480	50/60 Hz	<b>EOP5T15</b>
24	DC	<b>EOP5T21</b>
48	DC	<b>EOP5T22</b>
125	DC	<b>EOP5T26</b>

**R-Frame Electrical (Motor) Operator**

Operating Voltage	Frequency	Factory-Installed Terminal Block
		Catalog Number
120	50/60 Hz	<b>EOP6T08K</b>
240	50/60 Hz	<b>EOP6T11K</b>
48	DC	<b>EOP6T21K</b>

**Plug-In Adapters****F-Frame Ordering Information (Flat Bar Type)**

Continuous Current Rating (Amperes)	Two-Pole Catalog Number	Three-Pole Catalog Number	Four-Pole Catalog Number
100–225	<b>1480D13G01</b>	<b>1480D13G02</b>	<b>1480D13G07</b> <sup>①</sup>
Mounting plate	<b>176C511H01</b>	<b>507C047H01</b>	—

**J-Frame Ordering Information (Flat Bar Type)**

Continuous Current Rating (Amperes)	Terminal End	Two-Pole Catalog Number	Three-Pole Catalog Number	Four-Pole Catalog Number
250	Line	<b>1260C86G05</b>	<b>1260C86G06</b>	<b>1231C67G01</b>
	Load	<b>1260C86G07</b>	<b>1260C86G08</b>	<b>1231C67G02</b>
	One line and one load	<b>506C144G27</b>	<b>506C144G28</b>	—
Mounting plate	—	<sup>②</sup>	<b>PMP23</b>	—

**K-Frame Ordering Information (Flat Bar Type)—600 Vac Maximum**

Continuous Current Rating (Amperes)	Two-Pole Catalog Number	Three-Pole Catalog Number	Four-Pole Catalog Number
400	<b>PAD32</b>	<b>PAD33</b>	—
Mounting plate	<sup>②</sup>	<b>PMP33</b>	—

**Notes**

<sup>①</sup> 100 ampere maximum.

<sup>②</sup> Use three-pole mounting plate for two-pole circuit breaker.

**L-Frame (Threaded Stud Type)**

Continuous Current Rating (Amperes)	Two-Pole Catalog Number	Three-Pole Catalog Number	Four-Pole Catalog Number
600 (threaded stud type)	506C059G03	506C059G04	PAD44
600 (flat bar type)	1288C19G01	1288C19G02	6636C55H01
Mounting plate	504C824H01	504C824H01	—

**M-Frame (Flat Bar Type)—600 Vac Maximum**

Continuous Current Rating (Amperes)	Two-Pole Catalog Number	Three-Pole Catalog Number
800	2614D53G05	2614D53G06
Mounting plate	1290C73H01	1290C73H01

**N-Frame (Flat Bar Type)**

Continuous Current Rating (Amperes)	Two-Pole Catalog Number	Three-Pole Catalog Number
1200	2614D53G03	2614D53G04
Mounting plate	1290C73H01	1290C73H01

**Plug-In Adapters**

Frame	Number of Poles	Standard Certification	Catalog Number
FD	3	IEC	PAD3F
FD	4	IEC	PAD4F
JD	3	IEC	PAD3JD
KD	3	IEC	PAD3K
LD	3	IEC	PAD3LD
LD	4	IEC	PAD4LD

**Rear Connecting Studs****F-Frame** <sup>①</sup>

Stud Ampere Rating	Stud Catalog Number	Tube Catalog Number
<b>For 15 to 100 Ampere Circuit Breakers</b>		
100 A short	451D874G01	32B9446H20
100 A short	451D874G01	32B9446H21
100 A short	451D874G01	32B9446H22
100 A short	451D874G01	32B9446H23
100 A long	451D874G02	32B9446H24
100 A long	451D874G02	32B9446H25
100 A long	451D874G02	32B9446H26
100 A long	451D874G02	32B9446H27
<b>For 110 to 225 Ampere Circuit Breakers</b>		
225A short	374D883G01	374D883H06
225A short	374D883G01	374D883H07
225A short	374D883G01	374D883H08
225A short	374D883G01	374D883H09
225A long	374D883G02	374D883H10
225A long	374D883G02	374D883H11
225A long	374D883G02	374D883H12
225A long	374D883G02	374D883H13

**J-Frame** <sup>①</sup>

Stud Ampere Rating	Stud Catalog Number	Tube Catalog Number
250A short	5010D23G01	456D983H05
250A short	5010D23G01	456D983H06
250A short	5010D23G01	456D983H07
250A long	5010D23G02	5010D23H05
250A long	5010D23G02	5010D23H06
250A long	5010D23G02	5010D23H07

**K-Frame** <sup>①</sup>

Stud Ampere Rating	Stud Catalog Number	Standard Tube Catalog Number
400 A short	6642C14G02	313C909H17
400 A short	6642C14G04	313C909H18
400 A short	6642C14G06	313C909H19
400 A long	6642C14G03	313C909H20
400 A long	6642C14G05	313C909H21
400 A long	6642C14G07	313C909H22

**L-Frame Ordering Information**

Stud Catalog Number
314C960G07
314C960G08
314C960G09

**M-Frame Ordering Information** <sup>①</sup>

Stud Ampere Rating	Stud Catalog Number
225	314C960G01
400	314C960G04
400	314C960G05
400	314C960G06
600	314C960G07
600	314C960G08
600	314C960G09
800	314C960G10
800	314C960G11
800	314C960G12

**N-Frame Ordering Information** <sup>①</sup>

Stud Ampere Rating	Stud Catalog Number
800	623B222G01
800	623B222G02
800	623B222G03
1200	373B375G04
1200	373B375G03

**Note**

<sup>①</sup> Not UL listed.

**Panelboard Connecting Straps**

2

**F-Frame Panelboard Connecting Straps**

Bus Spacing in Inches (mm)	Continuous Current Rating (Amperes)	Pole Connector Type	
		Center Catalog Number	Outside Catalog Number
2.75 (69.9)	50	673B142G02	673B142G09
2.75 (69.9)	100	673B142G02	673B142G10
2.75 (69.9)	150	673B142G04	673B142G03
3.50 (88.9)	50	1253C72G01	1253C72G03
3.50 (88.9)	100	1253C73G03	1253C73G06
3.50 (88.9)	150	1253C73G01	1253C73G05

**F-Frame Mounting Bracket**

Number of Poles	Catalog Number
2	624B600H02
3	624B600H01

**J-Frame Panelboard Connecting Straps**

Bus Spacing in Inches (mm)	Continuous Current Rating (Amperes)	Pole Connector Type	
		Center Catalog Number	Outside Catalog Number
3.50 (88.9)	250	2600D26G01	2600D26G02

**K-Frame Panelboard Connecting Straps**

Bus Spacing in Inches (mm)	Continuous Current Rating (Amperes)	Pole Connector Type	
		Center Catalog Number	Outside Catalog Number
3.50 (88.9)	400	4212B78G02	4212B77G01

**K-Frame Mounting Bracket**

Number of Poles	Catalog Number
2, 3	208B264H01

**L-Frame Panelboard Connecting Straps**

Continuous Current Rating (Amperes)	Pole Connector Type	
	Center Catalog Number	Outside Catalog Number
600	624B609G01	506C052G01

**L-Frame Mounting Bracket**

Number of Poles	Catalog Number
2, 3	208B297H01

**M-Frame Panelboard Connecting Straps**

Bus Spacing in Inches (mm)	Continuous Current Rating (Amperes)	Pole Connector Type	
		Connector Type	Catalog Number
3.50 (88.9)	800	Short	314C996G01
		Medium	314C996G02
		Long	314C996G03

**M-Frame Mounting Bracket**

Catalog Number
315C270H01

**N-Frame Panelboard Connecting Straps**

Bus Spacing in Inches (mm)	Continuous Current Rating (Amperes)	Pole Connector Type	
		Connector Type	Catalog Number
3.50 (88.9)	1200	Short	505C606G04
		Medium	505C606G05
		Long	505C606G06

**N-Frame Mounting Bracket (Four Required)**

Catalog Number
315C270H01

#### Type LFD Current Limiter

The LFD current limiter is an accessory that bolts to the load end of a standard FDB or FD thermal-magnetic and electronic circuit breaker, providing 200,000 A

interrupting capacity at up to 600 Vac. LFD current limiters for thermal-magnetic circuit breakers are listed with Underwriters Laboratories under File E47239.

#### Type LFD Current Limiter



#### Type LFD Current Limiter

Circuit Breaker Rating Amperes	Catalog Number
15–70	LFD3070R
80–160	LFD3150R

#### Ground Fault Alarm Unit

The ground fault alarm unit is a remotely mounted device with a combination indicating light/test button that will light when the breaker trips or alarms on ground fault. The ground fault alarm unit requires a separate 120 Vac power source to power the

light and the internal relay, which has 1NO and 1NC contacts for remote indication. The ground fault alarm unit can be panel mounted for ordering with an optional face mounting bracket. For use on Digitrip 310 only, K- through N-Frame.

#### Ground Fault Alarm Unit



#### GF Alarm Unit

Description	Catalog Number
Ground fault alarm unit	GFAU
Face mounting bracket	1264C67G01

#### IQ Energy Sentinel

The IQ Energy Sentinel is a highly accurate, microprocessor-based, breaker-mounted device designed to monitor power and energy readings. It represents an alternative to watt meters, watt-hour meters, and watt demand meters. Key advantages include savings in space, lower installation costs, and remote monitoring capability.

The IQ Energy Sentinel mounts on the load side of a Series C F-Frame (150 ampere) circuit breaker. It can be applied on three-phase, four-wire systems, or single-phase, three-wire systems with voltage connected through Phases A and C.

For more information, see Descriptive Bulletin 8178.

#### Potential Transformer Module

The potential transformer module is required for the Digitrip OPTIM 1050 to provide a voltage input to allow the trip unit to monitor power and energy as well as power factor. The potential transformer module is a 6 VA transformer with a primary voltage input of up to 600 volt

line to line. Three 0.1 ampere fuses are provided on the primary of the transformer and can be used for isolation purposes during dielectric testing. The device is normally panel mounted and can feed up to 16 OPTIM trip units.

#### Potential Transformer Module



#### Potential Transformer Module

Description	Catalog Number
Potential transformer module	DOPTMLN

#### Solid-State (Electronic) Portable Test Kit

The solid-state (electronic) portable test kit provides verification of performance of all ratings of Digitrip 310 electronic trip units installed in circuit breakers while in service under varying load and/or phase imbalance. The test kit operates on 120-volt,

50/60 Hz power; it includes complete instructions and test times for testing long time, short time/ instantaneous operation and optional ground fault operation of the circuit breaker.

#### Portable Test Kit

Description	Catalog Number
Solid-state (electronic) portable test kit	STK2

**Breaker Interface Module (BIM)**

The Breaker Interface Module (BIM) is a panel mounted user interface device that is mounted on the front of an electrical assembly or at a remote location. The BIM is used to access, configure, test and display information for OPTIM trip units and other devices. The BIM consists of four display windows, eight function buttons, 18 LEDs, and a graphical time/current curve to provide breaker status, operational information, protection status and energy monitoring. A 24

Vdc power supply is required to provide power to the BIM. This is supplied by the switchboard builder to Eaton's specifications. The BIM is a member of Eaton's PowerNet family of communicating devices that connects OPTIM trip units, Digitrip RMS 810/910 trip units and energy sentinels as a subnetwork system. The BIM can also be connected to a main network via a PONI module to PowerNet software.

**Breaker Interface Module (BIM)****Breaker Interface Module (BIM)****Catalog Number****BIMII****Digitrip OPTIMizer**

The Digitrip OPTIMizer is a hand-held programmer that is used to access, configure, test and display information from OPTIM trip units. The OPTIMizer plugs into the front of an OPTIM trip unit via an eight-pin telephone jack and is powered by a nine-volt battery or the auxiliary power module. One highlighted feature is the "Copy" and "Download" commands.

Setting up multiple OPTIM trips can be finished in minutes and with no errors. An Auxiliary Power Module connection provides a trip test when control power is not present at the breaker. The OPTIMizer is supplied as a standard package to include

the programmer, the eight-pin connection cord, battery and carrying case. The auxiliary power module is optional.

**Note: 24 Vdc Power Supply**

A 24 Vdc power supply is required for all Digitrip OPTIM trip units that are required to communicate either on the main Eaton PowerNet network or as a subnetwork to a BIM. The breaker's load is 45 mA of current. Typically one power supply is required per switchboard and can provide control power to a BIM and the OPTIM trip units. The 24 Vdc power supply should be an "isolated high quality" power supply with a "CE" label, and is normally provided by the switchboard manufacturer to Eaton's recommendations.

**Digitrip OPTIMizer****Digitrip OPTIMizer****Catalog Number****OPTIMizer—standard package****Auxiliary Power Module**

The auxiliary power module is a power supply requiring 120 Vac input at 50 or 60 Hz that provides a 32 Vdc output. The auxiliary power module provides control power for testing an OPTIM trip unit when other means of control power is not available or for continuous OPTIMizer operation versus temporary with a battery. The auxiliary

power module connects into the top of the Digitrip OPTIMizer via a keyed receptacle. The main application for the auxiliary power module would be for the testing of a standalone non-communicating OPTIM breaker that ordinarily would not have control power.

**Auxiliary Power Module****Auxiliary Power Module****Catalog Number****PRTBAPMDV****Cause of Trip Display/Remote Mount Cause of Trip Display**

The Cause of Trip Display can be field-installed on any Digitrip RMS 310+ trip unit. The device provides breaker information through an LCD screen, such as cause of trip, phrase current, ground current and low loads. The display is ideal for troubleshooting common trips such as ground fault, long delay, and instantaneous/short delay.

The DIGIVIEW version will provide a local display at the breaker without additional wiring by connecting directly onto the trip unit. The DIGIVIEWR06 version has a 6 foot cable that allows users to mount the display on the outside of an enclosure door and connect to the trip unit that is contained inside the enclosure.

**Cause of Trip Display/Remote Mount Cause of Trip Display****Catalog Number****DIGIVIEW****DIGIVIEWR06****Cause of Trip LED Module**

The Cause of Trip LED Module can be field-installed on any Digitrip RMS 310+ trip unit. The device provides a cause of trip indication via LED. The Cause of Trip LED Module connects directly onto the trip unit. When the

breaker trips, the module indicates the cause of trip (long delay, short delay, instantaneous and ground) via LED indication. The module is reset after the breaker is reset.

**Cause of Trip LED Module****Catalog Number****TRIP-LED**

## Accessories

## 2

**Flex Shaft Accessories (F- through R-Frame)****NEMA 12 Safety Door Hardware for Flex Shaft and C371** <sup>①</sup>

Handle Length in Inches (mm)	Catalog Number <sup>②</sup>
4 (101.6)	C361KJ4
6 (152.4)	C361KJ6
Roller Latch <sup>③</sup>	C361KR

**Series C Rotary Accessories**

As an option, an auxiliary switch is offered so that the control panel builder may electrically indicate the status of the breaker.

This accessory would be mounted on the mechanism and comes with 24-inch (609.6 mm) pigtail leads.

**Series C Auxiliary Switch**

Catalog Number
5108A61G01

**Wire Seal**

The wire seal can be used to secure the cover on the trip unit to prevent adjustments after settings are confirmed.

**Wire Seal**

Description	Catalog Number
Wire seal	5108A03H01

**Notes**

- ① Customer: Consult with box manufacturer for correct door hardware and any adapters required for assembly.
- ② The 1/4-inch x 1/2-inch (6.35 x 12.7 mm) standard mill rectangular locking bar is not supplied with these kits.
- ③ Third roller latch for use with 4- or 6-inch (101.6 or 152.4 mm) handle when 3 point latching is required.

## Technical Data and Specifications

### Electrical Operator

#### F-Frame Electrical (Solenoid) Operator Rating Data <sup>①②</sup>

Voltage <sup>③</sup>	Frequency	Inrush Current Amperes	Maximum Operating Time	Fuse Amperes <sup>④</sup>
120	50/60 Hz AC	10	5 cycles (80 ms)	3
240	50/60 Hz AC	5	5 cycles (80 ms)	2

#### F-Frame Electrical (Motor) Operator Rating Data <sup>②③⑥⑦</sup>

Voltage <sup>③</sup>	Frequency	Inrush Current Amperes
120	AC	2
24	DC	5
48	DC	3
125	DC	2

#### J-Frame Electrical (Solenoid) Operator Rating Data <sup>①⑥⑧⑨</sup>

Voltage <sup>③</sup>	Inrush Current Amperes	Fuse Amperes
120	30	6
240	16	4

#### K-Frame Electrical (Solenoid) Operator Rating Data <sup>①⑥⑧⑨</sup>

Operating Voltage <sup>③</sup>	Inrush Current Amperes	Fuse Amperes
120	30	6
240	16	4

#### L- and M-Frame Electrical (Motor) Operator Rating Data

<sup>①⑥⑧⑩</sup>

Operating Voltage <sup>③</sup>	Inrush Current Amperes
120 AC	31
208 AC	13
240 AC	12
125 DC	21
24 DC	50

#### N-Frame Electrical (Motor) Operator Rating Data <sup>①⑥⑩⑫</sup>

Operating Voltage <sup>③</sup>	Frequency	Inrush Current Amperes	Fuse Amperes
120	50/60 Hz	31	6
208	50/60 Hz	21	—
240	50/60 Hz	19	4
480	50/60 Hz	—	—
24	DC	50	—
48	DC	80	—
125	DC	21	—

#### R-Frame Electrical (Motor) Operator Rating Data <sup>③④⑫⑬</sup>

Operating Voltage <sup>⑦</sup>	Frequency	Motor Inrush Current Amperes
120	50/60 Hz	40
240	50/60 Hz	27
48	DC	53
24	DC	58

#### Notes

- ① UL listed under UL File E64983.
  - ② The electrical operator design is endurance tested for 8000 electrical operations.
  - ③ Tolerance: +10%, -15% of nominal voltage.
  - ④ Use current-limiting type fuse where required.
  - ⑤ UL listed under UL File E64124.
  - ⑥ Frequency: 50/60 Hz.
  - ⑦ Maximum operating time: 3 seconds max. Operator is an intermittent duty device. The safe duty cycle (OFF to ON to OFF) should not exceed one per minute.
  - ⑧ The electrical operator design has been endurance tested for 6000 electrical operations.
  - ⑨ Maximum operating time: 5 cycles (80 ms).
  - ⑩ Maximum operating time: 12 cycles.
  - ⑪ The electrical operator design has been endurance tested for 2,500 electrical operations.
  - ⑫ Maximum operating time: 12 cycles max. Operator is an intermittent duty device. The safe duty cycle (OFF to ON to OFF) should not exceed one per minute.
  - ⑬ Operator is an intermittent duty service. The safe duty cycle (OFF to ON to OFF) should not exceed one per minute.
  - ⑭ Electric Operating time at rated voltage; (a) To turn breaker ON—1/2 second max. (b) To turn breaker OFF—1/2 second max.
  - ⑮ Motor operating temperature; Class "A" temperature limits apply.
  - ⑯ A minimum 1 kVA power source is recommended for motor operation.
  - ⑰ Applied voltage should be no less than 85% or no more than 110% of rated voltage.
- For OPTIM trip, OPEOPCK kit required.

# 2.3

## Molded Case Circuit Breakers

### Series C

#### Dimensions

Approximate Dimensions in Inches (mm)

2

#### Rear Connecting Studs

##### F-Frame <sup>①</sup>

Stud Ampere Rating	Stud Catalog Number	Panel Thickness		Tube Length		Tube Catalog Number	Dimensions		
		A		B	C		D	E	F
<b>For 15 to 100 Ampere Circuit Breakers</b>									
100 A short	<b>451D874G01</b>	1.00 (25.4)		1.06 (26.9)	—	<b>32B9446H20</b>	—	3.63 (92.1)	0.31 (7.9)–18
100 A short	<b>451D874G01</b>	0.69–0.94 (17.5 to 23.8)		1.38 (34.9)	—	<b>32B9446H21</b>	—	3.63 (92.1)	0.31 (7.9)–18
100 A short	<b>451D874G01</b>	0.38–0.63 (9.5 to 15.9)		1.69 (42.9)	—	<b>32B9446H22</b>	—	3.63 (92.1)	0.31 (7.9)–18
100 A short	<b>451D874G01</b>	0.25–0.31 (6.4 to 7.9)		2.00 (50.8)	—	<b>32B9446H23</b>	—	3.63 (92.1)	0.31 (7.9)–18
100 A long	<b>451D874G02</b>	1.00 (25.4)		—	3.44 (87.3)	<b>32B9446H24</b>	6.13 (155.6)	—	0.31 (7.9)–18
100 A long	<b>451D874G02</b>	0.69–0.94 (17.5 to 23.8)		—	3.75 (95.2)	<b>32B9446H25</b>	6.13 (155.6)	—	0.31 (7.9)–18
100 A long	<b>451D874G02</b>	0.38–0.63 (9.5 to 15.9)		—	4.06 (103.1)	<b>32B9446H26</b>	6.13 (155.6)	—	0.31 (7.9)–18
100 A long	<b>451D874G02</b>	0.25–0.31 (6.4 to 7.9)		—	4.38 (111.3)	<b>32B9446H27</b>	6.13 (155.6)	—	0.31 (7.9)–18
<b>For 110 to 225 Ampere Circuit Breakers</b>									
225A short	<b>374D883G01</b>	1.00 (25.4)		1.06 (26.9)	—	<b>374D883H06</b>	—	4.25 (108.0)	0.44 (11.1)–14
225A short	<b>374D883G01</b>	0.69–0.94 (17.5 to 23.8)		1.38 (34.9)	—	<b>374D883H07</b>	—	4.25 (108.0)	0.44 (11.1)–14
225A short	<b>374D883G01</b>	0.38–0.63 (9.5 to 15.9)		1.69 (42.9)	—	<b>374D883H08</b>	—	4.25 (108.0)	0.44 (11.1)–14
225A short	<b>374D883G01</b>	0.25–0.31 (6.4 to 7.9)		2.00 (50.8)	—	<b>374D883H09</b>	—	4.25 (108.0)	0.44 (11.1)–14
225A long	<b>374D883G02</b>	1.00 (25.4)		—	3.44 (87.3)	<b>374D883H10</b>	7.50 (190.5)	—	0.44 (11.1)–14
225A long	<b>374D883G02</b>	0.69–0.94 (17.5 to 23.8)		—	3.75 (95.2)	<b>374D883H11</b>	7.50 (190.5)	—	0.44 (11.1)–14
225A long	<b>374D883G02</b>	0.38–0.63 (9.5 to 15.9)		—	4.06 (103.1)	<b>374D883H12</b>	7.50 (190.5)	—	0.44 (11.1)–14
225A long	<b>374D883G02</b>	0.25–0.31 (6.4 to 7.9)		—	4.38 (111.3)	<b>374D883H13</b>	7.50 (190.5)	—	0.44 (11.1)–14

##### F-Frame

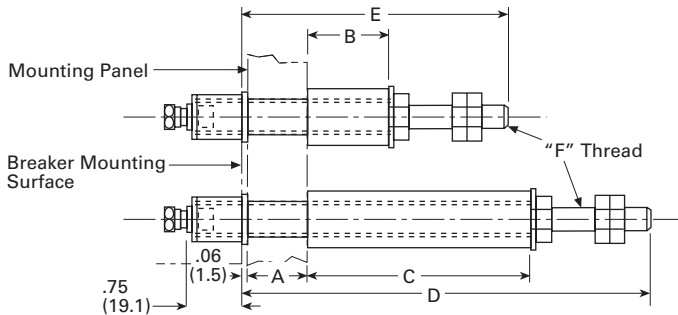

##### Note

<sup>①</sup> Not UL listed.

Approximate Dimensions in Inches (mm)

**J-Frame**

Stud Ampere Rating	Stud Catalog Number	Panel Thickness		Tube Length		Tube Catalog Number
		A		B	C	
250A short	5010D23G01	0.75–1.00 (19.1–25.4)		0.84 (21.4)	—	456D983H05
250A short	5010D23G01	0.50–0.75 (12.7–19.1)		1.09 (27.7)	—	456D983H06
250A short	5010D23G01	0.25–0.50 (6.4–12.7)		1.03 (26.2)	—	456D983H07
250A long	5010D23G02	0.75–1.00 (19.1–25.4)		—	3.88 (98.6)	5010D23H05
250A long	5010D23G02	0.50–0.75 (12.7–19.1)		—	4.13 (104.9)	5010D23H06
250A long	5010D23G02	0.25–0.50 (6.4–12.7)		—	4.38 (111.3)	5010D23H07

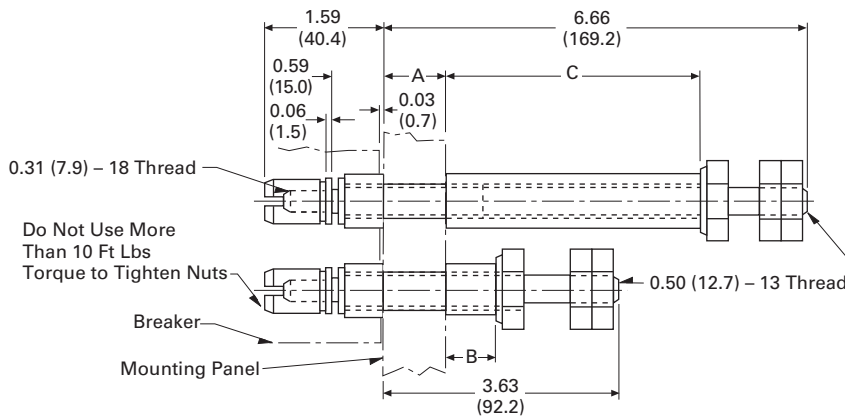

**K-Frame** ①

Stud Ampere Rating	Stud Catalog Number	Panel Thickness		Tube Length		Standard Tube Catalog Number	Dimensions		
		A		B	C		D	E	F
400 A short	6642C14G02	0.75–1 (19.1–25.4)		0.84 (21.3)	—	313C909H17	—	3.66 (93.0)	0.75–16 (19.1–406.4)
400 A short	6642C14G04	0.50–0.75 (12.7–18.4)		1.09 (27.69)	—	313C909H18	—	—	—
400 A short	6642C14G06	0.25–0.5 (6.35–12.7)		1.03 (26.16)	—	313C909H19	—	—	—
400 A long	6642C14G03	0.75–1 (19.1–25.4)		—	3.78 (96.0)	313C909H20	—	—	—
400 A long	6642C14G05	0.50–0.75 (12.7–18.4)		—	4.03 (102.4)	313C909H21	6.58 (167.1)	—	—
400 A long	6642C14G07	0.25–0.5 (6.35–12.7)		—	4.28 (108.7)	313C909H22	—	—	—

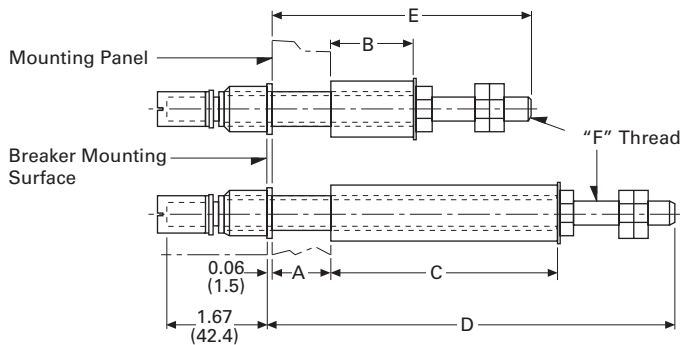

**Note**

① Not UL listed.

# 2.3

## Molded Case Circuit Breakers

### Series C

Approximate Dimensions in Inches (mm)

2

#### L-Frame

Stud Length (A)	Stud Catalog Number
5.47 (138.9)	314C960G07
7.97 (202.4)	314C960G08
10.47 (265.9)	314C960G09

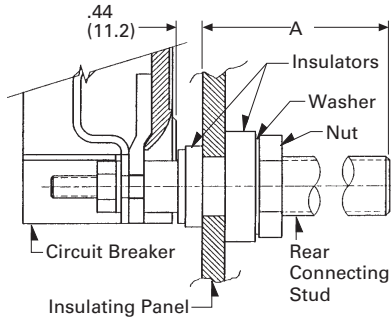

#### M-Frame

Stud Ampere Rating	Diameter and Thread	Extension Back of Breaker	Stud Catalog Number
225	0.50 (12.7)–13	3.66 (93.0)	314C960G01
400	0.75 (19.1)–16	5.91 (150.1)	314C960G04
400	0.75 (19.1)–16	8.41 (213.6)	314C960G05
400	0.75 (19.1)–16	10.91 (277.0)	314C960G06
600	1.00 (25.4)–12	5.91 (150.1)	314C960G07
600	1.00 (25.4)–12	8.41 (213.6)	314C960G08
600	1.00 (25.4)–12	10.91 (277.0)	314C960G09
800	1.13 (28.7)–12	5.91 (150.1)	314C960G10
800	1.13 (28.7)–12	8.41 (213.6)	314C960G11
800	1.13 (28.7)–12	10.91 (277.0)	314C960G12

#### N-Frame

Stud Ampere Rating	Diameter and Thread	Extension Back of Breaker	Stud Catalog Number
800	1.13 (28.7)–12	5.5 (139.7)	623B222G01
800	1.13 (28.7)–12	8.0 (203.2)	623B222G02
800	1.13 (28.7)–12	10.5 (266.7)	623B222G03
1200	1.25 (31.8)–12	5.5 (139.7)	373B375G04
1200	1.25 (31.8)–12	10.5 (266.7)	373B375G03

GP, FP, KP, LP and MP Frames



Definite Purpose Molded Case Circuit Breaker Family

## Contents

### Description

	<i>Page</i>
Product Selection Guide . . . . .	<b>V4-T2-332</b>
Electrical Characteristics . . . . .	<b>V4-T2-332</b>
Features . . . . .	<b>V4-T2-334</b>
Base Mounting Hardware . . . . .	<b>V4-T2-334</b>
Line and Load Termination . . . . .	<b>V4-T2-334</b>
Optional Line and Load Terminals . . . . .	<b>V4-T2-334</b>
Catalog Number Selection . . . . .	<b>V4-T2-335</b>
Product Selection . . . . .	<b>V4-T2-336</b>
Accessories . . . . .	<b>V4-T2-334</b>
Dimensions . . . . .	<b>V4-T2-337</b>

Learn  
OnlineDrawings  
Online

## Definite Purpose Molded Case Circuit Breakers

*Optimized solution for HVAC/R and Pumping Applications.*

### Product Overview

#### **GP, FP, KP, LP and MP Frames 15–800 Amperes NEMA 480 Vac**

Eaton's Definite Purpose molded case circuit breakers are available in three-pole configurations, and are designed to meet the specific requirements of HVAC/R and pumping applications.

As with other members of Eaton's family of molded case circuit breakers, Definite Purpose breakers provide high quality, reliability, unmatched performance and outstanding value.

Eaton's Definite Purpose breakers are rated from 15–800 A and are available in five frame sizes. Each frame size has the same compact outside dimensions as Series C breakers.

Additionally, Definite Purpose breakers have been rigorously tested to the UL 489 standard. They are assembled in an ISO certified facility.

#### **Trip Units and Terminals**

Definite Purpose breakers contain factory-sealed thermal-magnetic trip units.

The GP-Frame breaker (15–100 A) includes line and load terminals and breaker mounting hardware.

FP (15–225A), KP (200–400 A), LP (450–600 A) and MP (700–800 A) Frames ship standard without mounting hardware. For line and load terminals, add "L" to the end of the catalog number or "W" for no terminals.

#### **External Accessories**

Definite Purpose breakers use the same external accessories as Series C breakers: handle mechanisms, motor operators, lock-off devices, busbar extensions and multiple terminal arrangements.

# 2.4

## Molded Case Circuit Breakers

Definite Purpose

### Product Selection Guide

2

### Electrical Characteristics



Breaker Type	GPS	FPS	FPH	KPS	KPH
Amperage range	15–100 A	15–225A	15–225A	200–400 A	200–400 A
Performance level	<b>S</b>	<b>S</b>	<b>H</b>	<b>S</b>	<b>H</b>
Breaker capacity (kA rms)	240 Vac	65	65	100	65
NEMA, UL, CSA	480 Vac	22	35	65	65
	600 Vac	—	18	25	35
Number of poles	3	3	3	3	3
Maximum voltage (Vac)	480	600	600	600	600
Thermal-magnetic	■	■	■	■	■

Electrical Characteristics, continued



Breaker Type	LPS		LPH	MPS	MPH
Amperage range	450–600 A		450–600 A	700–800 A	700–800 A
Performance level	<b>S</b>		<b>H</b>	<b>S</b>	<b>H</b>
Breaker capacity (kA rms)	240 Vac	65	100	65	100
NEMA, UL, CSA	480 Vac	35	65	50	65
	600 Vac	25	35	25	35
Number of poles	3		3	3	3
Maximum voltage (Vac)	600		600	600	600
Thermal-magnetic	■		■	■	■

### Features

2

#### Base Mounting Hardware

English base mounting hardware is included with GP frame only. For all other frames, order base mounting hardware separately as per the table to the right.

#### Base Mounting Hardware

Frame	Catalog Number	
	English	Metric
GP	Included	—
FP	<b>BMH1</b>	<b>BMH1M</b>
KP	<b>BMH3</b>	<b>BMH3M</b>
LP	<b>BMH4</b>	<b>BMH4M</b>
MP	<b>BMH5</b>	<b>BMH5M</b>

**Note:** Base mounting hardware, is included with GP-Frame breakers. A separate catalog number is not required.

#### Line and Load Terminals

Both line and load terminals are included with GP-Frame Definite Purpose breakers. For all other frames, add “L” for line and load terminals to be included or “W” for no terminals.

#### Line and Load Termination

Breaker	Termination Type	Awg Wire Range	Metric Wire Range (mm)	Wire Type	Bolt Size English	Bolt Size Metric	Torque Lb-In	Torque Nm	Catalog Number
GP	Wire	#14–1/0	2.5–50	Cu only	—	—	45	5.1	Included

#### Optional Line and Load Terminals

Breaker	Maximum Amperes	Awg Wire Range	Wire Type	Catalog Number	Catalog Number with Control Wire Termination
FP	100	#14–#10	Cu/Al	<b>3T100FB</b> ①	—
	100	#8	Cu/Al	<b>3T100FB</b> ①	—
	100	#6–#4	Cu/Al	<b>3T100FB</b> ①	—
	100	#3–4/0	Cu/Al	<b>3T100FB</b> ①	—
	200	#3–4/0	Cu only	<b>3T150FB</b> ①	—
	225	#4–4/0	Cu/Al	<b>3TA225FB</b> ①	—
	225	#6–300	Cu/Al	<b>3TA225FDK3</b> ①	—
	225	#6–300	Cu/Al	<b>3TA225FDK</b> ①②	—
KP	400	250–500 (1)	Cu/Al	<b>TA350K</b>	—
	400	3/0–250 (2)	Cu/Al	<b>3TA400K</b> ①	<b>3TA400KCW</b>
LP	500	250–350 (2)	Cu/Al	<b>TA602LD</b>	<b>TA602LDCW</b>
	600	400–500 (2)	Cu/Al	<b>3TA603LDK</b> ①	<b>3TA603LDCW</b>
MP	800	3/0–400 (3)	Cu/Al	<b>TA800MA2</b>	<b>TA800MA2CWT</b>
	800	500–750 (2)	Cu/Al	<b>TA801MA</b>	<b>TA801MACWT</b>

### Accessories

#### End Cap Accessory Kit

End caps for line and load conductor termination are optional with each breaker. End caps secure the conductor with a ring-type connector. The kit includes one end cap, three cap screws, three nuts and three lock washers.

#### Series C Accessories

For internal accessories, see **Page V4-T2-273**.

For external accessories, see **Page V4-T2-304**.

#### Notes

- ① Package of three terminals.
- ② Replacement use only.

#### End Cap Accessory Kit

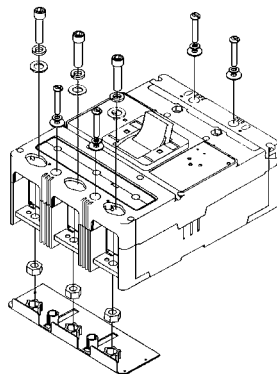

**Catalog Number Selection**

This information is presented only as an aid to understanding catalog numbers. It is not to be used to build catalog numbers for circuit breakers or trip units.

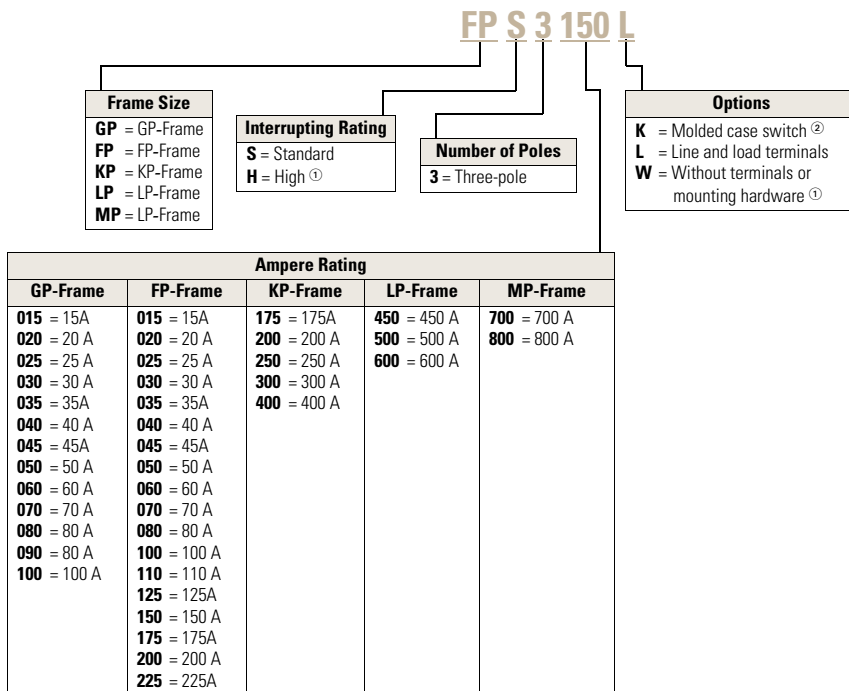

**Notes**

- ① Not available on GP-Frame.
- ② When choosing a molded case switch, select the highest amperage rating for the frame and the standard interrupting rating.

# 2.4

## Molded Case Circuit Breakers

### Definite Purpose

#### Product Selection

2

#### Catalog Numbers

When ordering Definite Purpose breakers, use the appropriate catalog numbers given below.

#### GP 100



#### GP-Frame/15–100 A

##### Frame/ Ampere Rating

GP/15–100 A circuit breakers

##### Three-Pole Catalog Number

GPS3015  
GPS3020  
GPS3025  
GPS3030  
GPS3035  
GPS3040  
GPS3045  
GPS3050  
GPS3060  
GPS3070  
GPS3080  
GPS3090  
GPS3100

GP/100 A molded case switch

GPS3100K

**Note:** All GP frames come standard with line and load terminals and base mounting hardware. Not available without terminals.

#### FP 225



#### FP-Frame/15–225 A

##### Frame/ Ampere Rating

FP/15–225A circuit breakers

##### Three-Pole Catalog Number

FPS3015  
FPS3020  
FPS3025  
FPS3030  
FPS3035  
FPS3040  
FPS3045  
FPS3050  
FPS3060  
FPS3070  
FPS3080  
FPS3090  
FPS3100  
FPS3110  
FPS3125  
FPS3150  
FPS3175  
FPS3200  
FPS3225  
FPH3015  
FPH3020  
FPH3025  
FPH3030  
FPH3035  
FPH3040  
FPH3045  
FPH3050  
FPH3060  
FPH3070  
FPH3080  
FPH3090  
FPH3100  
FPH3110  
FPH3125  
FPH3150  
FPH3175  
FPH3200  
FPH3225

FP/225A molded case switch

FPS3225K

**Note:** At the end of catalog number, add “L” for terminals or “W” for no terminals.

## KP 250

## KP-Frame/200–400 A

**Frame/  
Ampere Rating**

KP/175–400 A circuit breakers

**Three-Pole  
Catalog  
Number**

KPS3175

KPS3200

KPS3250

KPS3300

KPS3400

KPH3175

KPH3200

KPH3250

KPH3300

KPH3400

KP/400 A molded case switch

KPS3400K

**Dimensions**

Approximate Dimensions in Inches (mm)

All dimensions are provided for guidance and should not be used for construction purposes unless approved.

Contact Eaton for detailed outline drawings.

**GP, FP, KP, LP and MP Definite Purpose Frames**

	Breaker Type				
	GP	FP	KP	LP	MP
Width	3.00 (76.2)	4.13 (104.9)	5.49 (139.4)	8.25 (209.6)	8.25 (209.6)
Height	4.88 (124.0)	6.00 (152.4)	10.12 (257.0)	10.75 (273.1)	16.00 (406.4)
Depth	2.63 (66.7)	3.38 (85.9)	4.31 (109.6)	3.81 (96.8)	4.06 (103.1)

## LP 400

## LP-Frame/450–600 A

**Frame/  
Ampere Rating**

LP/450–600 A circuit breakers

**Three-Pole  
Catalog  
Number**

LPS3450

LPS3500

LPS3600

LPH3450

LPH3500

LPH3600

LP/600 A molded case switch

LPS3600K

## MP 800

## MP-Frame/700–800 A

**Frame/  
Ampere Rating**

MP/700–800 A circuit breakers

**Three-Pole  
Catalog  
Number**

MPS3700

MPS3800

MPH3700

MPH3800

MP/800 A molded case switch

MPS3800K

**Note:** For KP, LP, MP frames above, add "L" for terminals or "W" for no terminals to end of catalog number.

#### PM3 Modules

2



Power Monitoring and Metering with Modbus RTU

#### Contents

##### Description

	<i>Page</i>
PM3 Monitoring and Metering Module	
Product Selection . . . . .	<b>V4-T2-339</b>
Technical Data and Specifications . . . . .	<b>V4-T2-339</b>
Dimensions and Weights . . . . .	<b>V4-T2-340</b>



Learn  
Online



Drawings  
Online

### PM3 Monitoring and Metering Module

#### Product Description

The PM3 is the perfect solution for main, branch circuit and standalone monitoring/metering applications. With information at your fingertips, you can meter, monitor and communicate phase current and voltage with calculated power and energy.

The PM3 is versatile, as it connects to the load side of a molded-case circuit breaker (MCCB) and communicates easily to a local network or the Internet through Eaton Power Xpert® Gateways (PXGs). Cost of ownership is reduced through ease of installation. The PM3 is your ideal MCCB metering solution.

#### Application Description

- Communications via Modbus® and Eaton's INCOM™ protocol; compatible with Eaton's PXG for Web page and Ethernet capabilities
- Works in 240 Vac PM3, 480 Vac and 600 Vac applications
  - 480 Vac PM3 has internal power supply to power electronics
  - 600 Vac PM3 requires 24 Vdc auxiliary power
- Seamlessly integrates with thermal-magnetic or electronic trip units

#### Features and Benefits

- Communicates electrical system data and circuit breaker status
- Calculates power and energy to an accuracy of 1.0% of reading
- Configurable with thermal-magnetic or electronic trip units
- Suitable for reverse-feed applications
- Easy to install

#### PM3 Benefits When Combined with 310+ Electronic Trip Unit

- Alarming: high load and ground fault
- Zone selective interlocking
- Arcflash Reduction Maintenance System™
- Cause-of-trip localized information through Digiview and TRIP-LED
- Modbus/INCOM communications
- HMI connectivity through PXG
- Current and voltage metering to 0.5% of reading
- Power and energy monitoring to 1.0% of reading
- Reduces cost of ownership

#### Standards and Certifications

- Meets ANSI C12.1 revenue grade standard with a current and voltage accuracy of 0.5% of reading
- UL 489, Annex J
- IEC 61000-4-2—ESD
- IEC 61000-4-4—EFT
- IEC 61000-4-5—SURGE
- IEC 61000-4-6—EMC
- ANSI C12.1 (1% accuracy)
- UL/cUL/CE



## Product Selection

### PM3 Modules

Frame	Catalog Number	
	480 V	600 V
<b>Modbus</b>		
FD	—	<b>PM3FM</b>
JG	—	<b>PM3JM</b>
KD and LG	—	<b>PM3LM</b>
<b>INCOM</b>		
FD	<b>PM3FI480</b>	<b>PM3FI600</b>
JG	<b>PM3JI480</b>	<b>PM3JI600</b>
KD and LG	<b>PM3LI480</b>	<b>PM3LI600</b>

### End Cap Kits (Sold Separately)

Frame	Description	Catalog Number
FD	Metric end cap kit for F-Frame	<b>KPEKM1</b>
	English end cap kit for F-Frame	<b>KPEK1</b>
JG	Metric end cap kit for JG-Frame	<b>FJ3RTWK</b>
	English end cap kit for JG-Frame	<b>FJ3RTDK</b>
KD	Metric end cap kit for K-Frame	<b>KPEKM3</b>
	English end cap kit for K-Frame	<b>KPEK3</b>
LG	Metric end cap kit for LG-Frame	<b>L3RTWK</b>

## Technical Data and Specifications

### Metered parameters

- $I_A$ ,  $I_B$ ,  $I_C$
- $V_{AB}$ ,  $V_{BC}$ ,  $V_{CA}$ ,  $V_{an}$ ,  $V_{bn}$ ,  $V_{cn}$
- Apparent Energy, Forward Real Energy, Reverse Real Energy, Net Real Energy, Lagging Reactive Energy, Leading Reactive Energy, Net Reactive Energy
- Apparent Power A, B, C; Apparent Power Total; Reactive Power A, B, C; Reactive Power Total; Real Power A, B, C; Real Power Total
- Frequency, Apparent Power Factor, Apparent PFA, Apparent PFB, Apparent PFC

### PM3 Power Monitoring and Communications Module Technical Specifications for Modbus RTU

Description	Specification
<b>Current Inputs</b>	
Pickup current	0.3A rms
Maximum reported current	FD/JG 250 A rms KD/LD 630 A rms
Accuracy	0.5% of reading
<b>Voltage Inputs</b>	
Range	Line-to-neutral 30–366 Vac Line-to-line 52–635 Vac
Supported systems	Three-element wye, three-element wye + neutral Two-element delta, four-wire delta systems
Input impedance	996 kilohm/phase
Burden per phase	0.36 VA/phase max. at 600 V; 0.014 VA at 120V
Phase voltage connections	Internal via screw terminal to busbar For wye system, a neutral is required to be connected to the PM3 on the right Phoenix connector.
Neutral connection	If neutral is not available, the meter will calculate a virtual neutral based on the phase-to-phase rms voltage. The system voltage must be balanced for this to be accurate.
<b>Frequency</b>	
Frequency	50/60 Hz
Accuracy	± 0.1 Hz
Resolution	0.1 Hz
<b>Power and Energy</b>	
Accuracy	1% of reading (ANSI C12.1)
<b>Isolation</b>	
All inputs and outputs are galvanically isolated to 2500 V.	
<b>Environmental Ratings</b>	
Operating temperature	–20 °C to +50 °C
Storage temperature	–20 °C to +50 °C
Operating humidity	5 to 95% RH noncondensing
<b>Sensing Method</b>	
Voltage, current	True rms
Sampling rate	13.02K samples per second
<b>Update Rate</b>	
Watts, VAR and VA	1.03 sec at 60 Hz
All other parameters	1.07 sec at 60 Hz
<b>Power Supply (External)</b>	
DC voltage	18–30 Vdc
Maximum current	30.0 mA at 24 Vdc
Burden	0.72W
<b>Standard Communication Format</b>	
Connection type	Three-wire RS-485 (A, B, Common)
Com port baud rate	9600 or 19,200 bauds Default: 19,200 bauds
Modbus address range	01–247
Data format	Selectable (8, N, 1   8, N, 2   8, Even, 1   8, Odd, 1) Default: 8, N, 2
Protocols	Modbus RTU
Internal termination resistor selectable ON or OFF	Via DIP switch Default: Enabled

# 2.5

## Molded Case Circuit Breakers

### Metering and Communications

#### Dimensions and Weights

Approximate Dimensions in Inches (mm)

2

#### FD Three-Pole with PM3 Modbus

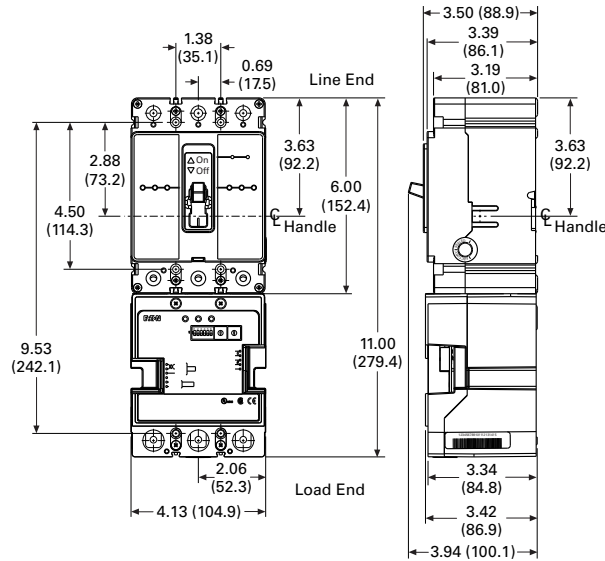

#### JG Three-Pole with PM3 Modbus

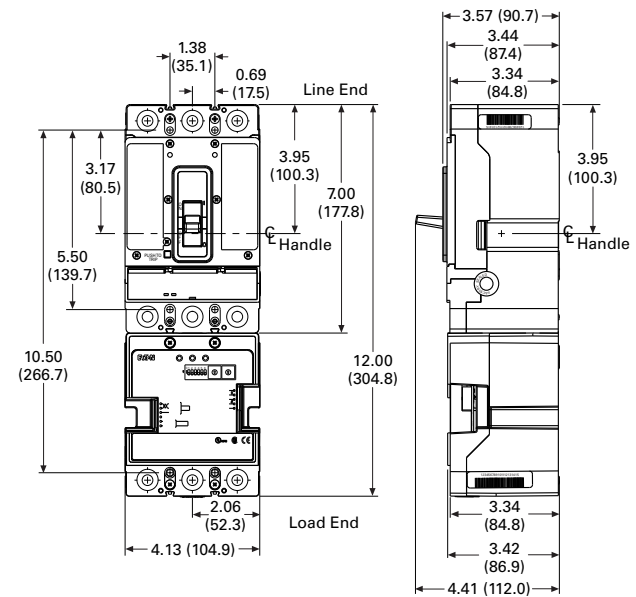

#### KD Three-Pole with PM3 Modbus

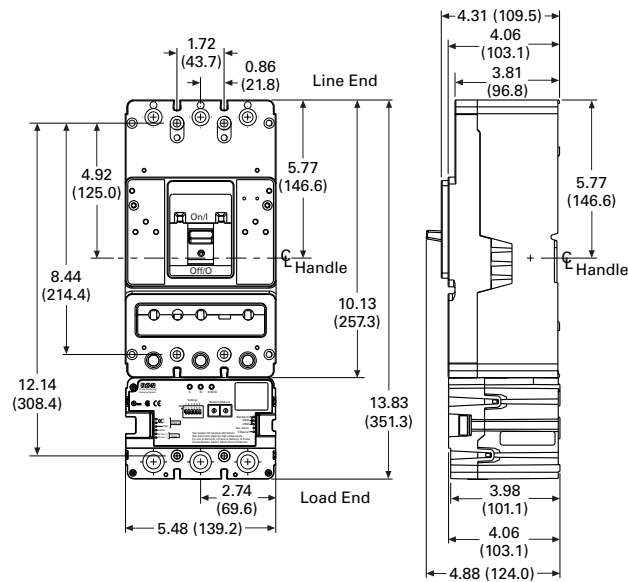

#### LG Three-Pole with PM3 Modbus

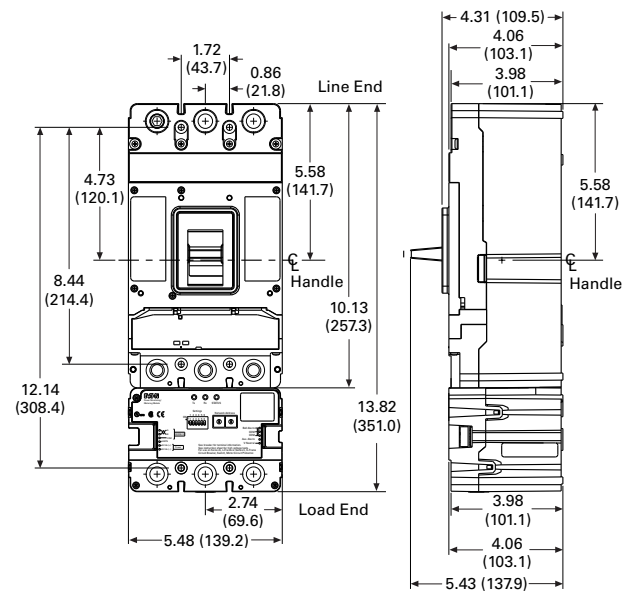

#### PM3 Dimensions and Shipping Weights

Description	Frame	Dimensions and Weights
Weight in lbs (kg)	FD	1.26 (0.57)
	JG	1.60 (0.73)
	KD/LG	2.25 (1.02)
Basic unit in inches (mm)	FD	4.13 W x 5.00 L x 3.39 H (104.9 x 127.0 x 86.1)
	JG	4.13 W x 5.00 L x 3.39 H (104.9 x 127.0 x 86.1)
	KD/LG	5.48 W x 3.70 L x 4.06 H (139.2 x 94.0 x 103.2)
Shipping container dimensions in inches (mm)	FD/JG	8.00 x 5.13 x 5.50 (203.2 x 130.3 x 139.7)
	KD/LG	6.25 x 8.25 x 7.00 (158.7 x 209.5 x 177.8)

## Engine Generator Circuit Breakers



## Contents

<i>Description</i>	<i>Page</i>
Engine Generator Circuit Breakers	
Catalog Number Selection . . . . .	V4-T2-342
Product Selection . . . . .	V4-T2-343
Accessories Selection Guide and Ordering Information . . . . .	V4-T2-345
Options and Accessories . . . . .	V4-T2-345
Technical Data and Specifications . . . . .	V4-T2-346
Dimensions and Weights . . . . .	V4-T2-346
Direct Current Circuit Breakers . . . . .	V4-T2-347
PVGard Solar Circuit Breakers—600 Vdc Per-Pole and 1000 Vdc Poles-in-Series . . . . .	V4-T2-361
E <sup>2</sup> Mining Service Circuit Breakers . . . . .	V4-T2-374
E2VAC Mining Vacuum Circuit Breaker . . . . .	V4-T2-400
Classic Mining Breakers . . . . .	V4-T2-403
Add-On Ground Fault Protection—Type GFR . . . . .	V4-T2-417

Learn  
OnlineDrawings  
Online

## Engine Generator Circuit Breakers

## Product Description

Eaton's engine generator molded case circuit breakers are designed specifically for application on diesel engine powered standby generators where high interrupting circuit breakers are not required. The JG through NG breakers are equipped with a special trip unit, that includes standard thermal (overload) protection and special low magnetic pickup range (FG includes a fixed thermal-magnetic pickup). The standard thermal trip unit provides overload protection for conductors per the National Electrical Code®. The low magnetic pickup range is approximately two to five times the continuous rating and provides closer low-level short-circuit protection when applied on generators that have very low short-circuit capacity. This combination allows the user to customize the breaker to the generator output.

## Application Description

Engine generator circuit breakers are suitable for reverse feed application.

## Standards and Certifications

Engine generator molded case circuit breakers are designed to conform with the following standards:

- Underwriters Laboratories Standard UL 489, Molded Case Circuit Breakers and Circuit Breaker Enclosures File E7819
- Canadian Standards Association Standard C22.2 No. 5, Service Entrance and Branch Circuit Breakers
- International Electrotechnical Commission Recommendations IEC 947-2, Circuit Breakers



Listed

Conformance with these standards satisfies most local and international codes, assuming user acceptability and simplified application.

# 2.6

## Molded Case Circuit Breakers

### Specialty Breakers

2

#### Catalog Number Selection

This information is presented only as an aid to understanding catalog numbers. It is not to be used to build catalog numbers for circuit breakers.

- FG breakers include both line and load side terminals

- JG, KG, LG and NG breakers with **W** catalog number suffix do not include any terminals
- JG, KG, LG and NG breakers without **W** catalog number suffix include both line and load terminals
- Contact Eaton for additional ratings and internal/external accessories
- Reverse feed

#### Circuit Breakers FG, JG, KG, LG and NG

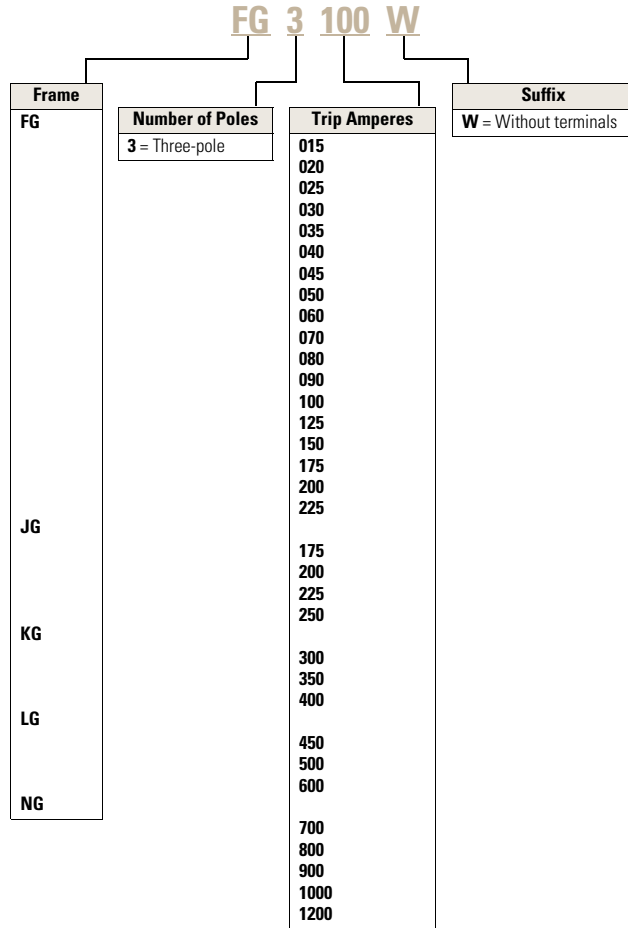

**Product Selection**

The following table lists FG through NG engine generator breakers with the maximum generator kVA and kW rating. Engine generator breakers are applied at 115% of the

generator full load current rating (FLA). The maximum kW rating is based on three-phase generators at 80% power factor.

**Thermal-Magnetic**

Magnetic Pickup Range	Maximum Generator Rating 60 Hz				600 Vac		Engine Generator Breaker <sup>③</sup>
	240 Vac kVA <sup>①</sup>	kW <sup>②</sup>	480 Vac kVA <sup>①</sup>	kW <sup>②</sup>	kVA <sup>①</sup>	kW <sup>②</sup>	Catalog Number
Fixed	5	4	11	9	14	11	FG3015 <sup>④</sup>
Fixed	7	6	14	12	18	14	FG3020 <sup>④</sup>
Fixed	9	7	18	14	23	18	FG3025 <sup>④</sup>
Fixed	11	9	22	17	27	22	FG3030 <sup>④</sup>
Fixed	13	10	25	20	32	25	FG3035 <sup>④</sup>
Fixed	14	12	29	23	36	29	FG3040 <sup>④</sup>
Fixed	16	13	32	26	41	32	FG3045 <sup>④</sup>
Fixed	18	14	36	29	45	36	FG3050 <sup>④</sup>
Fixed	22	17	43	35	54	43	FG3060 <sup>④</sup>
Fixed	25	20	51	40	63	51	FG3070 <sup>④</sup>
Fixed	29	23	58	46	72	58	FG3080 <sup>④</sup>
Fixed	32	26	65	52	81	65	FG3090 <sup>④</sup>
Fixed	36	29	72	58	90	72	FG3100 <sup>④</sup>
Fixed	40	32	79	64	99	79	FG3110 <sup>④</sup>
Fixed	45	36	90	72	113	90	FG3125 <sup>④</sup>
Fixed	54	43	108	87	135	108	FG3150 <sup>④</sup>
Fixed	63	51	126	101	158	126	FG3175 <sup>④</sup>
Fixed	72	58	144	116	181	144	FG3200 <sup>④</sup>
Fixed	81	65	162	130	203	162	FG3225 <sup>④</sup>
350–700	63	51	126	101	158	126	JG3175W <sup>⑤</sup>
350–700	63	51	126	101	158	126	JG3175 <sup>④</sup>
350–700	72	58	144	116	181	144	JG3200W <sup>⑤</sup>
350–700	72	58	144	116	181	144	JG3200 <sup>④</sup>
350–700	81	65	162	130	203	162	JG3225W <sup>⑤</sup>
350–700	81	65	162	130	203	162	JG3225 <sup>④</sup>
350–700	90	72	181	144	226	181	JG3250W <sup>⑤</sup>
350–700	90	72	181	144	226	181	JG3250 <sup>④</sup>
500–1000	108	87	217	173	271	217	KG3300W <sup>⑤</sup>
500–1000	108	87	217	173	271	217	KG3300 <sup>④</sup>
500–1000	126	101	253	202	316	253	KG3350W <sup>⑤</sup>
500–1000	126	101	253	202	316	253	KG3350 <sup>④</sup>
1000–2000	144	116	289	231	361	289	KG3400 <sup>④</sup>

**Notes**

- ① Breaker continuous current is based on 115% of the generator full load ampere rating.
- ② Based on three-phase generators at 80% power factor.
- ③ FG, JG, KG include thermal-magnetic trip units, LG and NG include electronic trip units.
- ④ Breaker includes line and load terminals.
- ⑤ Without terminals.

The following catalog numbers have center tap studs for dual voltage applications: JG3070CT, JG3100CT, JG3125CT, KG3175CT, LG3300CTW.

# 2.6

## Molded Case Circuit Breakers

### Specialty Breakers

#### Electronic

2

Magnetic Pickup Range	Maximum Generator Rating 60 Hz		480 Vac		600 Vac		Engine Generator Breaker <sup>③</sup>
	240 Vac kVA <sup>①</sup>	kW <sup>②</sup>	kVA <sup>①</sup>	kW <sup>②</sup>	kVA <sup>①</sup>	kW <sup>②</sup>	Catalog Number
500–2500	162	130	325	260	406	325	<b>LG3450</b> <sup>④</sup>
500–2500	181	144	361	289	451	361	<b>LG3500</b> <sup>④</sup>
500–2500	217	173	433	347	542	433	<b>LG3600</b> <sup>④</sup>
500–2500	253	202	505	404	632	505	<b>NG3700</b> <sup>④</sup>
500–2500	289	231	578	462	722	578	<b>NG3800</b> <sup>④</sup>
1250–5000	325	260	650	520	812	650	<b>NG3900</b> <sup>④</sup>
1250–5000	361	289	722	578	903	722	<b>NG31000</b> <sup>④</sup>
1250–5000	433	347	867	693	1083	867	<b>NG31200</b> <sup>④</sup>

#### Notes

- ① Breaker continuous current is based on 115% of the generator full load ampere rating.
- ② Based on three-phase generators at 80% power factor.
- ③ FG, JG, KG include thermal-magnetic trip units, LG and NG include electronic trip units.
- ④ Breaker includes line and load terminals.

The following catalog numbers have center tap studs for dual voltage applications: JG3070CT, JG3100CT, JG3125CT, KG3175CT, LG3300CTW.

## Accessories Selection Guide and Ordering Information

### Enclosures

#### Type 1 General Purpose

- Surface or flush mounting
- 15–1200 ampere range
- 600 Vac, 500 Vdc

Type 1 enclosed breakers are designed for use in commercial buildings, apartment buildings and other areas where a general purpose enclosure is applicable. The breaker is front operable and is capable of being padlocked in either the ON or OFF position. Ratings through 1200 amperes are listed with Underwriters Laboratories as approved for service entrance application. Both surface and flush mounted enclosures are available.

#### Type 3R Rainproof Surface Mounting

- Interchangeable hubs (through 400 amperes)
- 15–1200 ampere range
- 600 Vac, 500 Vdc

This general purpose outdoor service center employs a circuit breaker inside a weatherproof sheet steel breaker enclosure to serve

as a main disconnect and protective device for feeder circuits. Ratings through 1200 amperes are listed by Underwriters Laboratories as suitable for service entrance application.

#### Type 12 Dustproof Surface Mounting

- No knockouts or other openings
- 15–1200 ampere range
- 600 Vac, 500 Vdc

The Type 12 enclosure is designed in line with specifications for special industry applications where unusually severe conditions involving oil, coolant, dust and other foreign materials exist in the operating atmosphere. The handle padlocks in the OFF position and the cover is interlocked with the handle mechanism to prevent opening the cover with the circuit breaker in the ON position. Ratings through 1200 amperes are listed by Underwriters Laboratories as suitable for service entrance application.

### Enclosure Selection Data

Breaker Frame Amperes	Enclosure Type Class	Catalog Number
FG 15–225	Type 1	SFDN225
	Type 3R	RFDN225
	Type 12	JFDN225
JG 175–250	Type 1	SJDN250
	Type 3R	RJDN250
	Type 12	JJDN250
KG 300–400	Type 1	SKDN400
	Type 3R	RKDN400
	Type 12	JKDN400
LG 450–600	Type 1	SLDN600
	Type 3R	RLDN600
	Type 12	JLDN600
NG 700–1200	Type 1	SNDN1200
	Type 3R	RNDN1200
	Type 12	JNDN1200

## Options and Accessories

### Standard Terminals

Breaker Frame	Max. Amp Rating	AWG Wire Range	Metric Wire Range mm <sup>2</sup>	Catalog Number
FG	100	14–1/0	2.5–50	3T100FB ①
FG	150	4–4/0	25–95	3TA225FD ①
JG	250	4–350 kcmil	25–185	TA250KB
KG	350	250–500 kcmil	120–240	TA350K
KG	400	3/0–250 kcmil (2)	95–120	3TA400K ①
LG	600	250–500 kcmil (2)	120–240	3TA603LDK
NG	700	1–500 kcmil (2)	50–300	TA700NB1
NG	1000	3/0–400 kcmil (3)	95–185	TA1000NB1
NG	1200	4/0–500 kcmil (4)	120–300	TA1200NB1

### Neutral Kits, Insulated and Groundable

Max. Enclosure Rating (Amperes)	Main Lug Number Size Cu/Al	Ground Lug Size Cu/Al	Catalog Number
100	(1) 14–1/0	(1) 14–1/0	INK100
250	(1) 6–350 kcmil	(1) 4–300 kcmil	INK250
400	(1) 4–750 kcmil or (2) 1/0–250 kcmil	(1) 4–300 kcmil	INK400
600	(2) 250–500 kcmil	(1) 4–300 kcmil	INK600
1200	(3) 1/0 to 750 kcmil or (4) 1/0 to 750 kcmil	(1) 6–250 kcmil	INK1200

### Internal Accessories

#### Auxiliary Switch ②

Breaker Frame	Factory Mounted	1A-1B		2A-2B	
		Field Kit Catalog Number	Factory Mounted	Field Kit Catalog Number	Factory Mounted
FG ③	A06	A1X1PK	A13	A2X1RPK	A13
JG	A06	A1X2PK	A13	A2X2PK	A13
KG	A06	A1X3PK	A13	A2X3PK	A13
LG	A06	A1X4PK	A13	A2X4PK	A13
NG	A06	A1X5PK	A13	A2X5PK	A13

#### Shunt Trip ②

Breaker Frame	Rating	Factory Mounted	Field Kit Catalog Number
FG ③	12–24 Vdc	S02	SNT1LP03K
JG	12–24 Vdc	S42	SNT2P04K
KG	12–24 Vdc	S42	SNT3P04K
LG	12–24 Vdc	S02	SNT4LP03K
NG	12–24 Vdc	S02	SNT5LP03K

#### Notes

- ① Package of three terminals.
- ② Other accessories are available. Same as standard frame breakers.
- ③ Field installation on the FG Frame is not UL listed.

# 2.6

## Molded Case Circuit Breakers

### Specialty Breakers

#### Technical Data and Specifications

2

#### UL 489 Interrupting Capacity Ratings

Volts AC (50/60 Hz)	Interrupting Capacity (Symmetrical Amperes)
240	18,000
480	14,000
600	10,000

#### IEC 947-2 Interrupting Capacity Ratings

Volts AC (50/60 Hz)	Interrupting Capacity (Symmetrical Amperes)
220, 240	18,000/9,000
380, 415	14,000/7,000
660, 690	18,000/9,000 14,000/7,000 10,000/5,000

#### Dimensions and Weights

Approximate Dimensions in Inches (mm)

#### Enclosure Selection Data

Breaker Frame Amperes	Enclosure Type Class	A	B	C	D	E	Approx. Weight Lbs (kg)	Conduit Sizes, Inches	Catalog Number
FG 15–225	Type 1	23.25 (590.6)	8.41 (213.6)	6.28 (159.5)	18.75 (476.3)	1.20 (30.5)	15 (7)	0.25, 0.50, 0.75, 1, 1.25, 1.50, 2, 2.50	SFDN225
	Type 3R	25.66 (651.8)	8.84 (224.7)	9.31 (236.5)	24.28 (616.7)	1.70 (43.2)	19 (9)	0.25, 0.50, 0.75, 1, 1.25, 1.50, 2, 2.50	RFDN225
	Type 12	25.66 (651.8)	8.84 (224.7)	9.31 (236.5)	24.28 (616.7)	1.70 (43.2)	18 (8)	—	JFDN225
JG 175–250	Type 1	34.70 (881.4)	10.92 (277.4)	7.20 (182.9)	30.00 (762.0)	1.88 (47.8)	31 (14)	0.25, 0.50, 2, 2.50, 3	SJDN250
	Type 3R	37.50 (952.5)	11.56 (293.6)	10.22 (259.6)	35.77 (908.6)	1.94 (49.3)	40 (18)	0.25, 0.50, 2, 2.50, 3	RJDN250
	Type 12	37.53 (953.3)	11.56 (293.6)	10.22 (259.6)	35.77 (908.6)	1.94 (49.3)	37 (17)	—	JJDN250
KG 300–400	Type 1	38.81 (985.8)	11.06 (280.9)	10.94 (277.9)	34.00 (863.6)	2.28 (57.9)	53 (24)	0.25, 0.50, 0.75, 1.50, 2, 2.50, 3, 3.50	SKDN400
	Type 3R	41.69 (1058.9)	11.75 (298.5)	14.06 (357.1)	39.90 (1013.5)	1.97 (50.0)	60 (27)	0.25, 0.50, 0.75, 2.50, 3, 3.50	RKDN400
	Type 12	41.69 (1058.9)	11.75 (298.5)	14.06 (357.1)	39.90 (1013.5)	1.97 (50.0)	53 (24)	—	JKDN400
LG 450–600	Type 1	45.88 (1165.4)	14.31 (363.5)	12.38 (314.5)	46.56 (1182.6)	1.91 (48.5)	81 (37)	0.25, 0.50, 0.75, 3, 3.50, 4	SLDN600
	Type 3R	48.31 (1227.1)	14.91 (378.7)	15.50 (393.7)	46.56 (1182.6)	1.92 (48.8)	84 (38)	0.25, 0.50, 0.75, 3, 3.50, 4	RLDN600
	Type 12	48.31 (1227.1)	14.91 (378.7)	15.50 (393.7)	46.56 (1182.6)	1.92 (48.8)	81 (37)	—	JLDN600
NG 700–1200	Type 1	61.22 (1555.0)	21.44 (544.6)	15.41 (391.4)	61.84 (1570.7)	1.97 (50.0)	178 (81)	—	SNDN1200
	Type 3R	63.59 (1615.2)	22.00 (558.8)	17.63 (447.8)	61.84 (1570.7)	1.97 (50.0)	175 (79)	—	RNDN1200
	Type 12	63.59 (1615.2)	22.00 (558.8)	17.63 (447.8)	61.84 (1570.7)	1.97 (50.0)	170 (77)	—	JNDN1200

#### Type 1 Surface Mounted

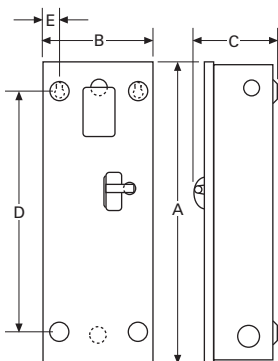

#### Type 3R Rainproof

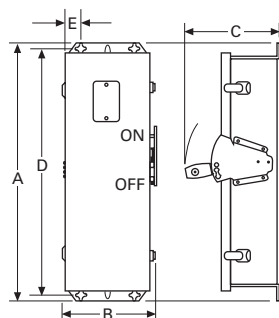

#### Type 12, 12K Dustproof

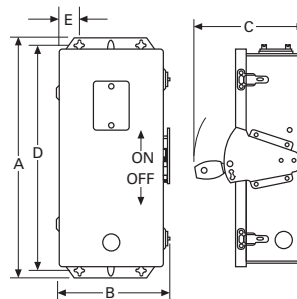

**Direct Current Circuit Breakers****Direct Current Circuit Breakers****Product Description**

DC (direct current) systems and applications are becoming commonplace as alternative energy sources have expanded and the number of DC devices and data centers using DC power has swelled.

Eaton offers molded case circuit breakers and switches to meet circuit protection and switching requirements for a host of different DC end user requirements. Applications include UPS battery supply circuits, solar systems and electric vehicle charging, as well as commercial and industrial distribution.

Current ratings are available from 15 to 3000 A, with a full scale of voltage and interrupting ratings to address needs ranging from standard to the highest performance. Optional internal accessories provide remote tripping and indication of breaker status.

The DC breaker family is UL 489 listed and exceeds the requirements in UL 489 Supplement SC for UPS applications. Eaton breakers may be applied in both ungrounded and select grounded applications, with poles connected in series to operate at the maximum voltages shown on **Page V4-T2-348**. To use DC circuit breakers on 600 V grounded systems, three poles in series must be connected on the ungrounded leg.

**Contents****Description**

	<b>Page</b>
Engine Generator Circuit Breakers . . . . .	<b>V4-T2-341</b>
Direct Current Circuit Breakers	
Catalog Number Selection . . . . .	<b>V4-T2-349</b>
Product Selection . . . . .	<b>V4-T2-350</b>
Accessories . . . . .	<b>V4-T2-357</b>
Wiring Diagrams . . . . .	<b>V4-T2-359</b>
Dimensions . . . . .	<b>V4-T2-360</b>
PVGard Solar Circuit Breakers—600 Vdc Per-Pole and 1000 Vdc Poles-in-Series . . . . .	<b>V4-T2-361</b>
E <sup>2</sup> Mining Service Circuit Breakers . . . . .	<b>V4-T2-374</b>
E2VAC Mining Vacuum Circuit Breaker . . . . .	<b>V4-T2-400</b>
Classic Mining Breakers . . . . .	<b>V4-T2-403</b>
Add-On Ground Fault Protection—Type GFR . . . . .	<b>V4-T2-417</b>

All DC breakers use the same internal and external accessories as their corresponding Series C and Series G AC frame equivalents, except for the NBDC breaker, which uses the same internal and external accessories as the standard NB frame.

The HFDDC through HMDLDC and EG to RG DC breakers use the same internal and external accessories as their corresponding Series C and Series G AC Frame equivalents. NBDC uses the same internal and external accessories as standard NB breakers.

Many of the Eaton AC molded case circuit breakers carry 250 Vdc ratings for ungrounded systems. Refer to **Pages V4-T2-9** and **V4-T2-118** for these interrupting tables.

# 2.6

## Molded Case Circuit Breakers

### Specialty Breakers

#### Quick Reference Direct Current Circuit Breakers

#### UL 489 Interrupting Capacity Ratings

2

Circuit Breaker Type	Maximum Amperes	Interrupting Capacity (kA) Volts DC <sup>①</sup>								
		125	Poles in Series	250 <sup>②</sup>	Poles in Series	500	600	Poles in Series	750 <sup>②</sup>	Poles in Series
EGEDC	100	10	1	35	2	35	—	3	—	—
EGSDC	100	35	1	42	2	50	—	3	—	—
EGHDC	100	42	1	50	2	65	—	3	—	—
HFDDC	225	42	1	50	2	—	42	3	42	4
JGEDC	250	35	1	35	2	—	35	3	—	—
JGSDC	250	42	1	42	2	—	50	3	—	—
JGHDC	250	50	1	50	2	—	65	3	—	—
HJDDC	250	42	1	50	2	—	42	3	—	—
HKDDC	400	42	1	50	2	—	42	3	—	—
LGEDC	600	22	1	22	2	—	35	3	—	—
LGSDC	600	22	1	22	2	—	50	3	—	—
LGHDC	600	50	1	50	2	—	65	3	—	—
HLDDC	600	42	1	50	2	—	35	3	—	—
HLDDC <sup>③</sup>	1200	42	1	50	2	—	—	—	—	—
HMDLDC	800	42	1	50	2	—	35	3	—	—
NBDC	1200	42	1	50	2	—	50	3	—	—
RGHDC	3000	42	1	50	2	—	65	3	—	—

#### IEC 60947-2 Interrupting Capacity Ratings

Circuit Breaker Type	Maximum Amperes	125 Volts DC		Poles in Series	250 Volts DC		Poles in Series	600 Volts DC		Poles in Series
		I <sub>cu</sub>	I <sub>cs</sub>		I <sub>cu</sub>	I <sub>cs</sub>		I <sub>cu</sub>	I <sub>cs</sub>	
EGEDC	100	10	10	1	10	10	2	—	—	—
EGSDC	100	35	35	1	35	35	2	—	—	—
EGHDC	100	42	42	1	42	42	2	—	—	—
JGEDC	250	22	22	1	22	22	2	—	—	—
JGSDC	250	22	22	1	22	22	2	—	—	—
JGHDC	250	42	42	1	42	42	2	—	—	—
HJDDC	250	—	—	—	—	—	—	20	10	3
LGEDC	600	22	22	1	22	22	2	—	—	—
LGSDC	600	22	22	1	22	22	2	—	—	—
LGHDC	600	42	42	1	42	42	2	—	—	—
HLDDC	600	—	—	—	—	—	—	20	10	3
HMDLDC	800	—	—	—	—	—	—	20	10	3

#### Notes

- ① DC ratings apply to substantially non-inductive circuits. Time constants per UL 489.
- ② EGEDC through HMDLDC have been tested up to 300 Vdc to allow for battery charging voltages. 750 Vdc is common in transportation applications. HFDDC, four-pole 750 Vdc is available up to 150 A maximum. 300 Vdc and 750 Vdc are not UL 489 listed voltage ratings.
- ③ Four-pole frame with two-poles connected in parallel.

See **Page V4-T2-359** for series connection diagrams. Use NEC rated cable to connect/short poles in series as shown.

### Catalog Number Selection

This information is presented only as an aid to understanding catalog numbers. It is not to be used to build catalog numbers for circuit breakers or trip units.

### DC Circuit Breaker

**HFDDC 3 150 W**

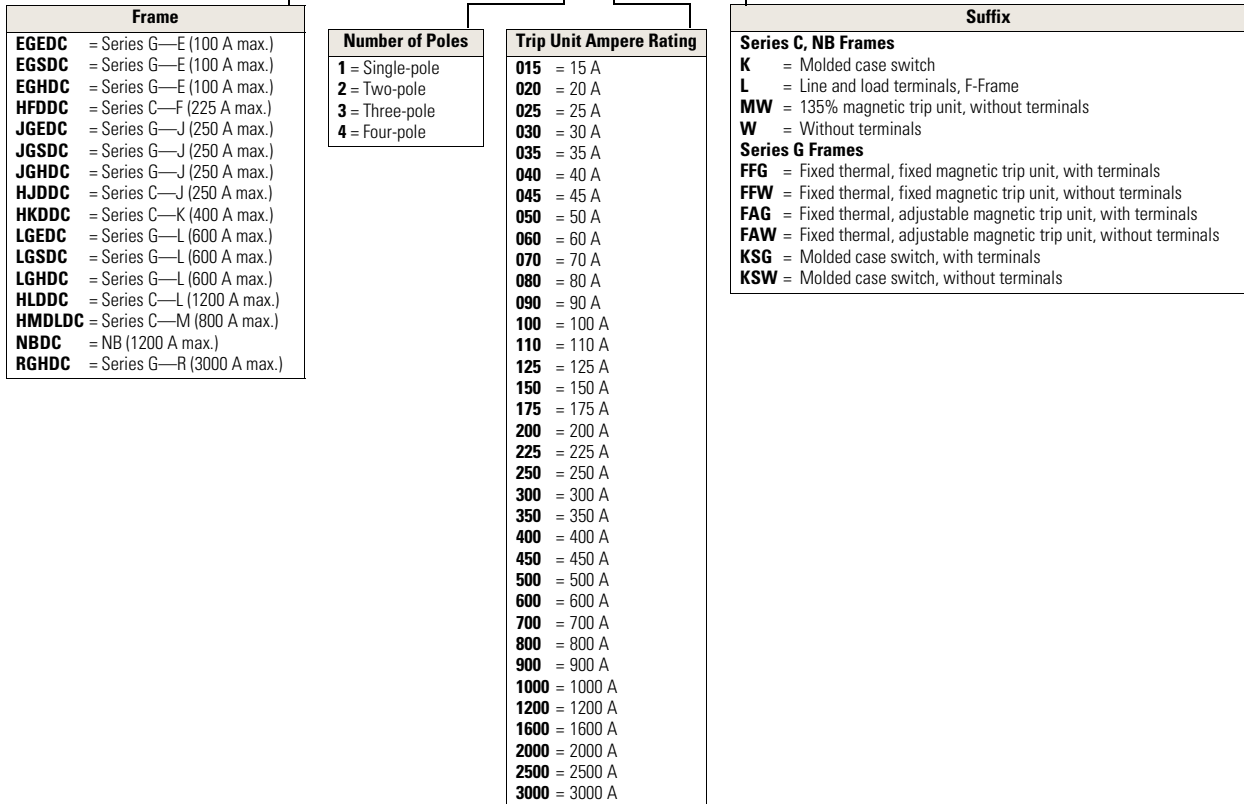

# 2.6

## Molded Case Circuit Breakers

### Specialty Breakers

#### Product Selection

2

#### Type EGEDC DC Circuit Breakers— Three-Pole High Interrupting Capacity 35 kAIC at 500 Vdc

Maximum Continuous Ampere Rating at 40 °C	Complete Circuit Breaker with Terminals Catalog Number	Complete Circuit Breaker without Terminals Catalog Number
25	EGEDC3025FFG	EGEDC3025FFW
30	EGEDC3030FFG	EGEDC3030FFW
35	EGEDC3035FFG	EGEDC3035FFW
40	EGEDC3040FFG	EGEDC3040FFW
45	EGEDC3045FFG	EGEDC3045FFW
50	EGEDC3050FFG	EGEDC3050FFW
60	EGEDC3060FFG	EGEDC3060FFW
70	EGEDC3070FFG	EGEDC3070FFW
80	EGEDC3080FFG	EGEDC3080FFW
90	EGEDC3090FFG	EGEDC3090FFW
100	EGEDC3100FFG	EGEDC3100FFW

#### Type EGSDC DC Circuit Breakers— Three-Pole High Interrupting Capacity 50 kAIC at 500 Vdc

Maximum Continuous Ampere Rating at 40 °C	Complete Circuit Breaker with Terminals Catalog Number	Complete Circuit Breaker without Terminals Catalog Number
25	EGSDC3025FFG	EGSDC3025FFW
30	EGSDC3030FFG	EGSDC3030FFW
35	EGSDC3035FFG	EGSDC3035FFW
40	EGSDC3040FFG	EGSDC3040FFW
45	EGSDC3045FFG	EGSDC3045FFW
50	EGSDC3050FFG	EGSDC3050FFW
60	EGSDC3060FFG	EGSDC3060FFW
70	EGSDC3070FFG	EGSDC3070FFW
80	EGSDC3080FFG	EGSDC3080FFW
90	EGSDC3090FFG	EGSDC3090FFW
100	EGSDC3100FFG	EGSDC3100FFW

#### Type EGHDC DC Circuit Breakers— Three-Pole High Interrupting Capacity 65 kAIC at 500 Vdc

Maximum Continuous Ampere Rating at 40 °C	Complete Circuit Breaker with Terminals Catalog Number	Complete Circuit Breaker without Terminals Catalog Number
25	EGHDC3025FFG	EGHDC3025FFW
30	EGHDC3030FFG	EGHDC3030FFW
35	EGHDC3035FFG	EGHDC3035FFW
40	EGHDC3040FFG	EGHDC3040FFW
45	EGHDC3045FFG	EGHDC3045FFW
50	EGHDC3050FFG	EGHDC3050FFW
60	EGHDC3060FFG	EGHDC3060FFW
70	EGHDC3070FFG	EGHDC3070FFW
80	EGHDC3080FFG	EGHDC3080FFW
90	EGHDC3090FFG	EGHDC3090FFW
100	EGHDC3100FFG	EGHDC3100FFW

## HFDDC

**Type HFDDC DC Circuit Breakers—  
Three-Pole High Interrupting Capacity 42 kAIC at 600 Vdc**

Maximum Continuous Ampere Rating at 40 °C	Complete Circuit Breaker with Line and Load Terminals <sup>①</sup>			
	Single-Pole Catalog Number	Two-Pole Catalog Number	Three-Pole Catalog Number	Four-Pole Catalog Number
15	HFDDC1015L	HFDDC2015L	HFDDC3015L	HFDDC4015L
20	HFDDC1020L	HFDDC2020L	HFDDC3020L	HFDDC4020L
25	HFDDC1025L	HFDDC2025L	HFDDC3025L	HFDDC4025L
30	HFDDC1030L	HFDDC2030L	HFDDC3030L	HFDDC4030L
35	HFDDC1035L	HFDDC2035L	HFDDC3035L	HFDDC4035L
40	HFDDC1040L	HFDDC2040L	HFDDC3040L	HFDDC4040L
45	HFDDC1045L	HFDDC2045L	HFDDC3045L	HFDDC4045L
50	HFDDC1050L	HFDDC2050L	HFDDC3050L	HFDDC4050L
60	HFDDC1060L	HFDDC2060L	HFDDC3060L	HFDDC4060L
70	HFDDC1070L	HFDDC2070L	HFDDC3070L	HFDDC4070L
80	HFDDC1080L	HFDDC2080L	HFDDC3080L	HFDDC4080L
90	HFDDC1090L	HFDDC2090L	HFDDC3090L	HFDDC4090L
100	HFDDC1100L	HFDDC2100L	HFDDC3100L	HFDDC4100L
110	HFDDC1110L	HFDDC2110L	HFDDC3110L	HFDDC4110L
125	HFDDC1125L	HFDDC2125L	HFDDC3125L	HFDDC4125L
150	HFDDC1150L	HFDDC2150L	HFDDC3150L	HFDDC4150L
175	—	HFDDC2175L	HFDDC3175L	—
200	—	HFDDC2200L	HFDDC3200L	—
225	—	HFDDC2225L	HFDDC3225L	—

**Type JGEDC DC Circuit Breakers—  
Three-Pole High Interrupting Capacity 35 kAIC at 600 Vdc**

Maximum Continuous Ampere Rating at 40 °C	Complete Breaker Catalog Number	Circuit Breaker Frame Only <sup>②</sup> Catalog Number	Thermal-Magnetic Trip Unit Catalog Number	Standard Terminals Catalog Number
70	JGEDC3070FAG	JGEDC3250NN	JT3070FA	T250FJ
90	JGEDC3090FAG	JGEDC3250NN	JT3090FA	T250FJ
100	JGEDC3100FAG	JGEDC3250NN	JT3100FA	T250FJ
125	JGEDC3125FAG	JGEDC3250NN	JT3125FA	T250FJ
150	JGEDC3150FAG	JGEDC3250NN	JT3150FA	T250FJ
175	JGEDC3175FAG	JGEDC3250NN	JT3175FA	T250FJ
200	JGEDC3200FAG	JGEDC3250NN	JT3200FA	T250FJ
225	JGEDC3225FAG	JGEDC3250NN	JT3225FA	T250FJ
250	JGEDC3250FAG	JGEDC3250NN	JT3250FA	T250FJ

**Notes**

① For breaker without terminals, replace "L" with "W" at end of catalog number.

② For complete breaker, order individual frame, trip unit and terminals for field installation.

#### Type JGSDC DC Circuit Breakers— Three-Pole High Interrupting Capacity 50 kAIC at 600 Vdc

Maximum Continuous Ampere Rating at 40 °C	Complete Breaker Catalog Number	Circuit Breaker Frame Only <sup>①</sup> Catalog Number	Thermal-Magnetic Trip Unit Catalog Number	Standard Terminals Catalog Number
70	JGSDC3070FAG	JGSDC3250NN	JT3070FA	T250FJ
90	JGSDC3090FAG	JGSDC3250NN	JT3090FA	T250FJ
100	JGSDC3100FAG	JGSDC3250NN	JT3100FA	T250FJ
125	JGSDC3125FAG	JGSDC3250NN	JT3125FA	T250FJ
150	JGSDC3150FAG	JGSDC3250NN	JT3150FA	T250FJ
175	JGSDC3175FAG	JGSDC3250NN	JT3175FA	T250FJ
200	JGSDC3200FAG	JGSDC3250NN	JT3200FA	T250FJ
225	JGSDC3225FAG	JGSDC3250NN	JT3225FA	T250FJ
250	JGSDC3250FAG	JGSDC3250NN	JT3250FA	T250FJ

JGHDC3250NN



#### Type JGHDC DC Circuit Breakers— Three-Pole High Interrupting Capacity 65 kAIC at 600 Vdc

Maximum Continuous Ampere Rating at 40 °C	Complete Breaker Catalog Number	Circuit Breaker Frame Only <sup>①</sup> Catalog Number	Thermal-Magnetic Trip Unit Catalog Number	Standard Terminals Catalog Number
70	JGHDC3070FAG	JGHDC3250NN	JT3070FA	T250FJ
90	JGHDC3090FAG	JGHDC3250NN	JT3090FA	T250FJ
100	JGHDC3100FAG	JGHDC3250NN	JT3100FA	T250FJ
125	JGHDC3125FAG	JGHDC3250NN	JT3125FA	T250FJ
150	JGHDC3150FAG	JGHDC3250NN	JT3150FA	T250FJ
175	JGHDC3175FAG	JGHDC3250NN	JT3175FA	T250FJ
200	JGHDC3200FAG	JGHDC3250NN	JT3200FA	T250FJ
225	JGHDC3225FAG	JGHDC3250NN	JT3225FA	T250FJ
250	JGHDC3250FAG	JGHDC3250NN	JT3250FA	T250FJ

HJDDC3250



#### Type HJDDC DC Circuit Breakers— Three-Pole High Interrupting Capacity 42 kAIC at 600 Vdc

Maximum Continuous Ampere Rating at 40 °C	Circuit Breaker Frame Only <sup>①</sup> Catalog Number	Thermal-Magnetic Trip Unit Catalog Number	Standard Terminals Catalog Number
70	HJDDC3250F	JT3070T	TA250KB
90	HJDDC3250F	JT3090T	TA250KB
100	HJDDC3250F	JT3100T	TA250KB
125	HJDDC3250F	JT3125T	TA250KB
150	HJDDC3250F	JT3150T	TA250KB
175	HJDDC3250F	JT3175T	TA250KB
200	HJDDC3250F	JT3200T	TA250KB
225	HJDDC3250F	JT3225T	TA250KB
250	HJDDC3250F	JT3250T	TA250KB

**Note**

<sup>①</sup> For complete breaker, order individual frame, trip unit and terminals for field installation.

## HKDDC3400

**Type HKDDC DC Circuit Breakers—  
Three-Pole High Interrupting Capacity 42 kAIC at 600 Vdc**

Maximum Continuous Ampere Rating at 40 °C	Circuit Breaker Frame Only <sup>①</sup> Catalog Number	Thermal-Magnetic Trip Unit Catalog Number	Standard Terminals Catalog Number
100	HKDDC3400F	KT3100T	TA300K
125	HKDDC3400F	KT3125T	TA300K
150	HKDDC3400F	KT3150T	TA300K
175	HKDDC3400F	KT3175T	TA300K
200	HKDDC3400F	KT3200T	TA300K
225	HKDDC3400F	KT3225T	TA300K
250	HKDDC3400F	KT3250T	TA350K
300	HKDDC3400F	KT3300T	TA350K
350	HKDDC3400F	KT3350T	TA350K
400	HKDDC3400F	KT3400T	3TA400K <sup>②</sup>

## LGEDC3630NN

**Type LGEDC DC Circuit Breakers—  
Three-Pole High Interrupting Capacity 35 kAIC at 600 Vdc**

Maximum Continuous Ampere Rating at 40 °C	Complete Breaker Catalog Number	Circuit Breaker Frame Only <sup>①</sup> Catalog Number	Thermal-Magnetic Trip Unit Catalog Number	Standard Terminals Catalog Number
250	LGEDC3250FAG	LGEDC3630NN	LT3250FA	TA350LK
300	LGEDC3300FAG	LGEDC3630NN	LT3300FA	TA350LK
350	LGEDC3350FAG	LGEDC3630NN	LT3350FA	TA350LK
400	LGEDC3400FAG	LGEDC3630NN	LT3400FA	TA350LK
500	LGEDC3500FAG	LGEDC3630NN	LT4500FA	3TA632LK <sup>②</sup>
600	LGEDC3600FAG	LGEDC3630NN	LT3600FA	3TA632LK <sup>②</sup>

**Type LGSDC DC Circuit Breakers—  
Three-Pole High Interrupting Capacity 50 kAIC at 600 Vdc**

Maximum Continuous Ampere Rating at 40 °C	Complete Breaker Catalog Number	Circuit Breaker Frame Only <sup>①</sup> Catalog Number	Thermal-Magnetic Trip Unit Catalog Number	Standard Terminals Catalog Number
250	LGSDC3250FAG	LGSDC3630NN	LT3250FA	TA350LK
300	LGSDC3300FAG	LGSDC3630NN	LT3300FA	TA350LK
350	LGSDC3350FAG	LGSDC3630NN	LT3350FA	TA350LK
400	LGSDC3400FAG	LGSDC3630NN	LT3400FA	TA350LK
500	LGSDC3500FAG	LGSDC3630NN	LT4500FA	3TA632LK <sup>②</sup>
600	LGSDC3600FAG	LGSDC3630NN	LT3600FA	3TA632LK <sup>②</sup>

**Notes**

- ① For complete breaker, order individual frame, trip unit and terminals for field installation.  
 ② Three-pole kit.

### Type LGHDC DC Circuit Breakers— Three-Pole High Interrupting Capacity 65 kAIC at 600 Vdc

Maximum Continuous Ampere Rating at 40 °C	Complete Breaker Catalog Number	Circuit Breaker Frame Only <sup>①</sup> Catalog Number	Thermal-Magnetic Trip Unit Catalog Number	Standard Terminals Catalog Number
250	LGHDC3250FAG	LGHDC3630NN	LT3250FA	TA350LK
300	LGHDC3300FAG	LGHDC3630NN	LT3300FA	TA350LK
350	LGHDC3350FAG	LGHDC3630NN	LT3350FA	TA350LK
400	LGHDC3400FAG	LGHDC3630NN	LT3400FA	TA350LK
500	LGHDC3500FAG	LGHDC3630NN	LT4500FA	3TA632LK <sup>②</sup>
600	LGHDC3600FAG	LGHDC3630NN	LT3600FA	3TA632LK <sup>②</sup>

### HLDDC



### Type HLDDC DC Circuit Breakers— Three-Pole High Interrupting Capacity 35 kAIC at 600 Vdc

Maximum Continuous Ampere Rating at 40 °C	Circuit Breaker Frame Only <sup>①</sup> Catalog Number	Thermal-Magnetic Trip Unit Catalog Number	Standard Terminals Catalog Number
300	HLDDC3600F	LT3300T	TA602LD
350	HLDDC3600F	LT3350T	TA602LD
400	HLDDC3600F	LT3400T	TA602LD
450	HLDDC3600F	LT3450T	TA602LD
500	HLDDC3600F	LT3500T	TA602LD
600	HLDDC3600F	LT3600T	3TA603LDK <sup>②</sup>

### Type HLDDC DC Circuit Breakers— Two-Pole High Interrupting Capacity 50 kAIC at 250 Vdc <sup>③④</sup>

Maximum Continuous Ampere Rating at 40 °C	Complete Breaker Catalog Number
600	HLDDC20600
700	HLDDC20700
800	HLDDC20800
900	HLDDC20900
1000	HLDDC21000
1200	HLDDC21200

#### Notes

- <sup>①</sup> For complete breaker, order individual frame, trip unit and terminals for field installation.
- <sup>②</sup> Three-pole kit.
- <sup>③</sup> Includes breaker frame, trip unit and terminals.
- <sup>④</sup> Four-pole breaker with two poles wired in parallel.

## HMDLDC3800F

**Type HMDLDC DC Circuit Breakers—  
Three-Pole High Interrupting Capacity 35 kAIC at 600 Vdc**

Maximum Continuous Ampere Rating at 40 °C	Circuit Breaker Frame Only <sup>①</sup> Catalog Number	Thermal-Magnetic Trip Unit Catalog Number	Standard Terminals Catalog Number
300	HMDLDC3800F	MT3300T	TA700MA1
350	HMDLDC3800F	MT3350T	TA700MA1
400	HMDLDC3800F	MT3400T	TA700MA1
450	HMDLDC3800F	MT3450T	TA700MA1
500	HMDLDC3800F	MT3500T	TA700MA1
600	HMDLDC3800F	MT3600T	TA700MA1
700	HMDLDC3800F	MT3700T	TA700MA1
800	HMDLDC3800F	MT3800T	TA800MA2

**Type NBDC DC Circuit Breakers—  
Three-Pole High Interrupting Capacity 50 kAIC at 600 Vdc**

Maximum Continuous Ampere Rating at 40 °C	Complete Circuit Breaker Factory Assembled without Terminals <sup>②</sup> Catalog Number	Includes Magnetic Trip Unit Calibrated at 135%	Standard Terminals Catalog Number
700	NBDC3700MW	Included	TA1000NB1
800	NBDC3800MW	Included	TA1000NB1
900	NBDC3900MW	Included	TA1000NB1
1000	NBDC31000MW	Included	TA1000NB1
1200	NBDC31200MW	Included	TA1200NB1

## RGHDC3300FFWM

**Type RGHDC DC Circuit Breakers—  
Three-Pole High Interrupting Capacity 65 kAIC at 600 Vdc**

Maximum Continuous Ampere Rating at 40 °C	Complete Circuit Breaker Factory Assembled <sup>②</sup>		Includes Magnetic Trip Unit Calibrated at 135%	Standard Rear Connectors Catalog Number
	Imperial Mounting Hardware Catalog Number	Metric Mounting Hardware Catalog Number		
1600	RGHDC3160FFWE	RGHDC3160FFWM	Included	B2016RDM
2000	RGHDC3200FFWE	RGHDC3200FFWM	Included	B2016RDM
2500	RGHDC3250FFWE	RGHDC3250FFWM	Included	B2500RDM
3000	RGHDC3300FFWE	RGHDC3300FFWM	Included	B3000RDM

**Notes**

<sup>①</sup> Includes frame and trip unit. Order terminals or connectors separately.

<sup>②</sup> Six rear connectors included as standard complete circuit breaker.

## DC Breaker Terminal Wire Ranges

Breaker Frame	Maximum Breaker Ampacity	Terminal Body Material	Wire Type	AWG Wire Range/ Number of Conductors	Metric Wire Range mm <sup>2</sup>	Number of Terminals Included	Standard Terminal Catalog Number
EGEDC, EGSDC, EGHDC	100	Aluminum	Cu/Al	14–1/0	2.5–50	3	3TA125EF
HFDDC	20	Steel	Cu/Al	14–10 (1)	2.5–4 (1)	3	3T20FB
	100	Steel	Cu/Al	14–1/0 (1)	2.5–50 (1)	3	3T100FB
	225	Aluminum	Cu/Al	4–4/0 (1)	25–95 (1)	3	3TA225FD
	250	Stainless steel	Cu	4–350 (1)	25–185 (1)	1	T250FJ
HJDDC	250	Aluminum	Cu/Al	4–350 kcmil (1)	25–185 (1)	1	TA250KB
HKDDC	225	Aluminum	Cu/Al	3–350 kcmil (1)	35–185 (1)	1	TA300K
	350	Aluminum	Cu/Al	250–500 kcmil (1)	120–240 (1)	1	TA350K
	400	Aluminum	Cu/Al	3/0–250 kcmil (2)	95–120 (1)	3	3TA400K
LGEDC, LGSDC, LGHDC	400	Aluminum	Cu/Al	2–500 (1)	35–240 (1)	1	TA350LK
	630	Aluminum	Cu/Al	2–500 kcmil (2)	35–240 (2)	1	TA632L
	630	Aluminum	Cu/Al	2–500 kcmil (2)	35–240 (2)	3	3TA632LK
HLDDC	500	Aluminum	Cu/Al	3/0–350 kcmil (2)	95–150 (2)	1	TA602LD
	600	Aluminum	Cu/Al	400–500 kcmil (2)	185–240 (2)	3	3TA603LDK
HMDLDC	600	Aluminum	Cu/Al	1–500 kcmil (2)	—	1	TA700MA1
	800	Aluminum	Cu/Al	3/0–400 kcmil (3)	—	1	TA800MA2
NBDC	700	Aluminum	Cu/Al	3/0–400 kcmil (3)	95–185 (3)	1	TA1000NB1
	800	Aluminum	Cu/Al	3/0–400 kcmil (3)	95–185 (3)	1	TA1000NB1
	900	Aluminum	Cu/Al	3/0–400 kcmil (3)	95–185 (3)	1	TA1000NB1
	1000	Aluminum	Cu/Al	3/0–400 kcmil (3)	95–185 (3)	1	TA1000NB1
	1200	Aluminum	Cu/Al	4/0–500 kcmil (4)	120–240 (4)	1	TA1200NB1

**Note:** RGHDC breakers include six rear connectors as standard.

## Molded Case Switches

Eaton's DC molded case switches are used in applications requiring a compact, high-capacity disconnect. They are UL 489 listed and have automatic high instantaneous current protection. These devices do not provide overload protection.

## Molded Case Switches

Maximum Continuous Ampere Rating at 40 °C	Interrupting Capacity (Volts DC)	Poles in Series	With Line and Load Terminals	Without Line and Load Terminals
			Catalog Number	Catalog Number
<b>600 Vdc Maximum</b>				
100	42	3	HFDDC3100KL	HFDDC3100KW
150	42	3	HFDDC3150KL	HFDDC3150KW
225	42	3	HFDDC3225KL	HFDDC3225KW
250	65	3	JGKDC3250KSG	JGKDC3250KSW
250	42	3	HJDDC3250K	HJDDC3250KW
	35	3	HKDDC3400K	HKDDC3400KW
400	65	3	LGKDC3400KSG	LGKDC3400KSW
	65	3	LGKDC3630KSG	LGKDC3630KSW
600	35	3	HLDDC3600K	HLDDC3600WK
	35	3	HMDLDC3800K	HMDLDC3800WK
<b>500 Vdc Maximum</b>				
100	65	3	EGK3100KSG	EGK3100KSW
<b>250 Vdc Maximum</b>				
100	50	2	HFDDC2100KL	HFDDC2100KW
150	50	2	HFDDC2150KL	HFDDC2150KW
225	50	2	HFDDC2225KL	HFDDC2225KW
1200	50	①	HLDDC21200K ①	HLDDC21200WK ①

## Note

① Four-pole frame with two-pole connected in parallel.

## Accessories

## Internal Accessories

Description	Factory Installation (HFDDC)	Field Installation Kits								
		HFDDC ①	EGEDC, EGSDC, EGHDC	JGEDC, JGSDC, JGHDC	LGEDC, LGSDC, LGHDC	HJDDC	HKDDC	HLDDC	HMDLDC	NBDC
<b>Right-Pole Mounting</b>										
Auxiliary switch										
1A-1B	A06	A1X1PK	AUX1A1BPK	AUX1A1BPK	A1X2PK	A1X3PK	A1X4PK	A1X4PK	4980D16G05	—
2A-2B	A13	A2X1RPK	AUX2A2BPK	AUX2A2BPK	A2X2PK	A2X3PK	A2X4PK	A2X4PK	4980D16G06	A2X6RPK
Alarm switch										
1 make/1 break	B06	A1L1RPK	ALM1M1BEPK	ALM1M1BJPK	A1L2RPK	A1L3RPK	A1L4RPK	A1L4RPK	—	A1L6RPK
Auxiliary and alarm combo										
1A-1B, 1 make/1 break	C05	AAL1RPK	AUXALRMEPK	AUXALRMJPK	AAL2RPK	AAL3RPK	AA114RPK	AA114RPK	—	—
<b>Left-Pole Mounting</b>										
Shunt trip										
12 Vdc	S02	SNT1LP03K	SNT012CPK	SNT012CPK	SNT2P04K	SNT3P04K	SNT4LP03K	SNT4LP03K	2606D58G14	—
24 Vdc	S02	SNT1LP03K	SNT024CPK	SNT024CPK	SNT2P04K	SNT3P04K	SNT4LP03K	SNT4LP03K	2606D58G13	SNT6P03K ②
48 Vdc	S06	SNT1LP08K	SNT4860CPK	SNT4860CPK	SNT2P06K	SNT3P06K	SNT4LP23K	SNT4LP23K	2606D58G12	SNT6P23K ②
60 Vdc	S06	SNT1LP08K	SNT4860CPK	SNT4860CPK	SNT2P06K	SNT3P06K	SNT4LP23K	SNT4LP23K	2606D58G11	SNT6P23K ②
125 Vdc	S10	SNT1LP12K	SNT120CPK	SNT120CPK	SNT2P11K	SNT3P11K	SNT4LP26K	SNT4LP26K	2606D58G10	SNT6P23K ②
250 Vdc	S14	SNT1LP18K	—	—	SNT2P14K	SNT3P14K	SNT4LP14K	SNT4LP14K	2606D58G09	SNT6P14K
120 Vac	S06	SNT1LP12K	SNT120CPK	SNT120CPK	SNT2P11K	SNT3P11K	SNT4LP11K	SNT4LP11K	2060D58G05	SNT6P11K ②
Undervoltage release										
12 Vdc	U30	UVH1LP20K	UVR012DPK	UVR012DPK	UVH2LP20K	UVH3LP20K	UVH4LP20K	UVH4LP20K	372D032G06	UVH6RP20K ②
24 Vdc	U34	UVH1LP21K	UVR024DPK	UVR024DPK	UVH2LP21K	UVH3LP21K	UVH4LP21K	UVH4LP21K	372D032G07	UVH6RP21K ②
48 Vdc	U38	UVH1LP22K	UVR048DPK	UVR048DPK	UVH2LP22K	UVH3LP22K	UVH4LP22K	UVH4LP22K	372D032G08	UVH6RP23K ②
125 Vdc	U42	UVH1LP26K	UVR125DPK	UVR125DPK	UVH2LP26K	UVH3LP26K	UVH4LP26K	UVH4LP26K	372D032G09	UVH6RP26K ②
250 Vdc	U46	UVH1LP28K	UVR250DPK	UVR250DPK	UVH2LP28K	UVH3LP28K	UVH4LP28K	UVH4LP28K	372D032G10	UVH6RP28K ②
120 Vac	U14	UVH1LP08K	UVR120APK	UVR120APK	UVH2LP08K	UVH3LP08K	UVH4LP08K	UVH4LP08K	373D632G05	UVH6RP08K ②

**Notes**

① F-Frame circuit breakers are factory sealed. Underwriters Laboratories requires that internal accessories be installed at the factory. Internal accessories are UL listed for factory installation under E7819. Where local codes and standards permit and UL listing is not required, internal accessories can be field installed. Accessory installation should be done before the circuit breaker is mounted and connected.

② Right-pole mounted.

One accessory can be mounted per pole, per breaker. Factory installation of accessories is available. Contact Eaton for assistance with part number configuration.

**Jumpers**

Jumpers must be ordered separately. Priced individually.

2

**HFDDC Frame**

Description	Maximum Amperes	Catalog Number
Single copper jumper	60	DC1F060 <sup>①</sup>
	100	DC1F100 <sup>①</sup>
	125	DC1F125 <sup>①</sup>
	225	DC1F225 <sup>①</sup>
Package of 2 aluminum jumpers	100	DC2FD100A
Package of 3 aluminum jumpers	100	DC3FD100A

**JGEDC, JGSDC, JGHDC Frames**

Description	Maximum Amperes	Catalog Number
Single aluminum jumper	250	DC1JG250A <sup>①</sup>
Package of 2 aluminum jumpers	250	DC2JG250A <sup>①</sup>
Package of 20 aluminum jumpers	250	DC20JG250A <sup>①</sup>

**HKDDC Frame**

Description	Maximum Amperes	Catalog Number
Single copper jumper	400	DC1K400 <sup>①</sup>
Package of 2 aluminum jumpers	400	DC2KD400A <sup>①</sup>
Package of 3 aluminum jumpers	400	DC3KD400A <sup>①</sup>

**LGEDC, LGSDC, LGHDC Frames**

Description	Maximum Amperes	Catalog Number
Package of 2 aluminum jumpers	400	DC2LG400A
Package of 3 aluminum jumpers	400	DC3LG400A
Package of 30 aluminum jumpers	400	DC30LG400A

**Note**

<sup>①</sup> Not UL Listed; Non UL listed jumpers used in a UL application may need to be qualified by the OEM in their assembly. This may take place with UL or another certified testing agency.

**Wiring Diagrams**

**Series Connection Diagrams for DC Application ①②**

**250 Vdc Maximum—Two Poles in Series**

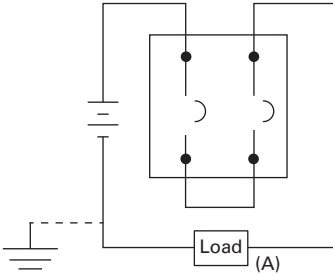

Suitable for use on ungrounded systems, or grounded systems that have one end of load (A) connected to grounded terminal, opposite poles in series connection.

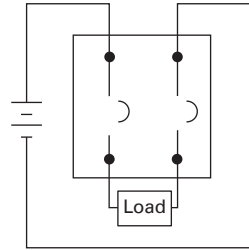

Suitable for use on ungrounded systems only.

**500 Vdc or 600 Vdc Maximum—Three Poles in Series**

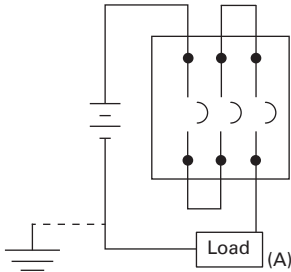

Suitable for use on ungrounded systems, or grounded systems that have one end of load (A) connected to grounded terminal, opposite poles in series connection.

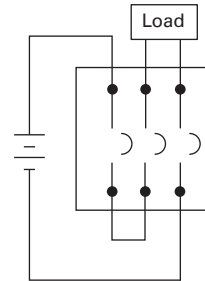

Suitable for use on ungrounded systems only.

**750 Vdc Maximum—Four Poles in Series**

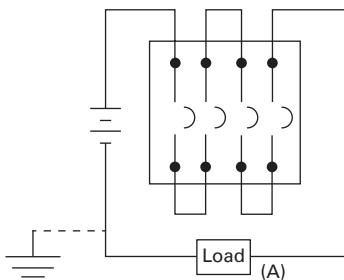

Suitable for use on ungrounded systems, or grounded systems that have one end of load (A) connected to grounded terminal, opposite poles in series connection.

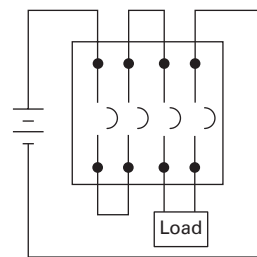

Suitable for use on ungrounded systems only.

**Notes**

- ① Poles in series connection is customer supplied. Use rated cable per NEC.
- ② For grounded systems, all poles in series must be connected on non-grounded terminal, with load connected to grounded terminal.

**Dimensions**

Approximate Dimensions in Inches (mm)

**2****DC Breaker Dimensions**

Frame	Number of Poles	Width	Height	Depth
EGEDC, EGSDC, EGHDC	3	3.00 (76.2)	5.50 (139.7)	2.99 (75.9)
HFDDC	1	1.38 (35.1)	6.00 (152.4)	3.38 (86.0)
	2	2.75 (70.0)	6.00 (152.4)	3.38 (86.0)
	3	4.13 (105.0)	6.00 (152.4)	3.38 (86.0)
	4	5.50 (139.7)	6.00 (152.4)	3.38 (86.0)
JGEDC, JGSDC, JGHDC	3	4.13 (104.9)	7.00 (177.8)	3.57 (90.7)
HJDDC	2, 3	4.13 (105.0)	10.00 (254.0)	4.06 (103.1)
HKDDC	2, 3	5.50 (139.7)	10.13 (257.3)	4.10 (104.1)
LGEDC, LGSDC, LGHDC	3	5.48 (139.2)	10.13 (257.3)	4.09 (103.9)
600 A Max. HLDDC	2, 3	8.25 (209.6)	10.75 (273.1)	4.06 (103.1)
1200 A Max. HLDDC	4	11.00 (279.4)	10.75 (273.1)	4.06 (103.1)
HMDLDC	2, 3	8.25 (209.6)	16.00 (406.4)	4.06 (103.1)
NBDC	3	8.25 (209.6)	16.00 (406.4)	5.50 (139.7)
RGHDC	3	15.50 (393.7)	16.00 (406.4)	9.75 (247.7)

## PVGard Solar Photovoltaic Circuit Breakers



600 Vdc Per-Pole

1000 Vdc Poles-in-Series

## Contents

## Description

	<i>Page</i>
Engine Generator Circuit Breakers . . . . .	<b>V4-T2-341</b>
Direct Current Circuit Breakers . . . . .	<b>V4-T2-347</b>
PVGard Solar Circuit Breakers—600 Vdc Per-Pole and 1000 Vdc Poles-in-Series	
Application Description . . . . .	<b>V4-T2-362</b>
Features . . . . .	<b>V4-T2-362</b>
Standards and Certifications . . . . .	<b>V4-T2-362</b>
Product Selection . . . . .	<b>V4-T2-363</b>
Accessories . . . . .	<b>V4-T2-365</b>
Technical Data and Specifications . . . . .	<b>V4-T2-369</b>
Dimensions . . . . .	<b>V4-T2-372</b>
Wiring Diagrams . . . . .	<b>V4-T2-373</b>
E <sup>2</sup> Mining Service Circuit Breakers . . . . .	<b>V4-T2-374</b>
Classic Mining Breakers . . . . .	<b>V4-T2-403</b>
Add-On Ground Fault Protection—Type GFR . . . . .	<b>V4-T2-417</b>

## PVGard Solar Circuit Breakers—600 Vdc Per-Pole and 1000 Vdc Poles-in-Series

## Product Overview

- Two PVGard lineups
  - 600 Vdc per-pole breaker and switch. Each pole rated 600 Vdc
  - 1000 Vdc poles-in-series breaker and switch. Requires poles in series connection
- Both options UL 489B listed for solar photovoltaic circuit protection
- 50 °C calibration
- Offers both 100% and 80% rated breakers
- Handle bi-directional current flow

## Product Description

Photovoltaic (PV) systems convert the energy of the sun into electrical power that is fed directly into the electric grid. Within the balance of system (BOS), direct current (DC) circuit breakers protect the wiring connected from the PV modules to the combiner or the inverter, while also behaving as a disconnect.

Eaton is a global leader in circuit protection and brings this expertise to bear in the photovoltaic market. PVGard solar circuit breakers are part of a product family that combines a disconnect with circuit protection in a single, compact, resettable device to protect and isolate DC circuits as needed in photovoltaic systems. PVGard breakers can replace fuses, fuse holders and disconnects in combiner box and inverter applications—saving space, streamlining design, purchasing and receiving, and reducing spare parts requirements.

There are two PVGard lineups to choose from: the industry-exclusive, 600 Vdc per-pole breakers and switches designed for residential and light commercial applications and 1000 Vdc poles-in-series breakers and switches for commercial and utility scale applications.

**PVGard 600 Vdc Per-Pole Lineup**

Only Eaton can offer this breakthrough breaker that will save significant space, time and cost. As a single-circuit-per-pole device, it allows space savings of up to 66% when compared to traditional poles-in-series disconnects, switches and breakers. In addition, it eliminates the need for jumpers for poles-in-series connection—saving on installation time, labor and even inventory.

**PVGard 1000 Vdc Poles-in-Series Lineup**

This 1000 Vdc poles-in-series lineup provides reliable and safe disconnect means and overcurrent protection in a single, compact device for commercial and utility scale PV systems. This solution does not require jumpers with the breaker/switch to be a UL 489B listed device, providing reliability and flexibility in design without limitation on implementation of the breaker/switch. If needed, cost-effective Eaton jumpers can be included.

**Application Description**

Photovoltaic (PV) systems convert the energy of the sun into electrical power that is fed directly into the electric grid. PVGuard circuit breakers are used to protect the wiring from the modules to the combiner box or inverter from overcurrents, and to provide an isolation mechanism.

Eaton offers a complete line of UL 489 Listed multi-purpose 600 Vdc poles-in-series breakers and switches, as well as protection for the AC side of the inverter. Refer to **Page V4-T2-347** for 600 Vdc breakers and **Page V4-T2-6** for AC breaker selection.

**Features**

PVGard breakers are uniquely designed with these features:

- Meets the higher voltage and lower fault current levels of solar systems
- Tested to extreme ambient conditions from  $-40^{\circ}\text{C}$  to  $+90^{\circ}\text{C}$
- Full complement of accessories for status, signalling, and on/off operation remotely
- Can handle bi-directional flow of current
- Can be applied in grounded, ungrounded or bi-polar systems
- Meets and exceeds the standards of UL 489B for photovoltaic molded case circuit breakers and molded case switches
- Available both standard (80%-rated) and 100%-rated breakers
- $50^{\circ}\text{C}$  calibration
- Ability to open on signal from DC arc or ground fault detector
- Wide range of current ratings increases options for matching incoming strings
- Eliminates fuse stocking costs and matching issues

Designed specifically for high- and low-temperature demands of PV installations, PVGuard circuit breakers undergo extreme ambient cycling tests, and carry a robust operating temperature range. Trip units calibrate at 100% and 80% of nameplate current in a  $50^{\circ}\text{C}$  ambient, ensuring continuous operation in higher temperature environments typical to solar.

Rigorous third-party testing includes limited and standard fault current tests, electrical and mechanical endurance, dielectric voltage withstand and temperature tests. Eaton's PVGuard products are stand-alone devices without requiring jumpers to be UL 489B listed devices.

PVGard breakers are available with a full complement of accessories to provide string status, enable remote trip, on/off operation, and can be customized to site requirements.

**Standards and Certifications**

- Designed to meet UL 489B for solar photovoltaic circuit protection
- UL File E350638, Category Control Number DIUR



**Product Selection**

Catalog number includes breaker frame and trip unit. Order terminals separately. See **Page V4-T2-367**.  
For complete internal and external accessories, see accessory section of each frame.

**JG PVS Frame****JG PVS Frame, 250 A Maximum, 600 Vdc Per Pole, 1.2 kA** <sup>①</sup>

Current Rating Amperes	Number Poles/ 600 Vdc Circuits	Trip Unit	80% Rated Catalog Number	100% Rated Catalog Number
90	3	Fixed thermal, fixed magnetic	<b>JGPVS3090W</b>	<b>CJGPVS3090W</b>
100	3	Fixed thermal, fixed magnetic	<b>JGPVS3100W</b>	<b>CJGPVS3100W</b>
125	3	Fixed thermal, fixed magnetic	<b>JGPVS3125W</b>	<b>CJGPVS3125W</b>
150	3	Fixed thermal, fixed magnetic	<b>JGPVS3150W</b>	<b>CJGPVS3150W</b>
175	3	Fixed thermal, fixed magnetic	<b>JGPVS3175W</b>	<b>CJGPVS3175W</b>
200	3	Fixed thermal, fixed magnetic	<b>JGPVS3200W</b>	<b>CJGPVS3200W</b>
225	3	Fixed thermal, fixed magnetic	<b>JGPVS3225W</b>	<b>CJGPVS3225W</b>
250	3	Fixed thermal, fixed magnetic	<b>JGPVS3250W</b>	<b>CJGPVS3250W</b>

**KD PVS Frame****KD PVS Frame, 400 A Maximum, 600 Vdc Per Pole, 3 kA** <sup>①</sup>

Current Rating Amperes	Number Poles/ 600 Vdc Circuits	Trip Unit	80% Rated Catalog Number	100% Rated Catalog Number
100	3	Fixed thermal, fixed magnetic	<b>KDPVS3100W</b>	<b>CKDPVS3100W</b>
125	3	Fixed thermal, fixed magnetic	<b>KDPVS3125W</b>	<b>CKDPVS3125W</b>
150	3	Fixed thermal, fixed magnetic	<b>KDPVS3150W</b>	<b>CKDPVS3150W</b>
175	3	Fixed thermal, fixed magnetic	<b>KDPVS3175W</b>	<b>CKDPVS3175W</b>
200	3	Fixed thermal, fixed magnetic	<b>KDPVS3200W</b>	<b>CKDPVS3200W</b>
225	3	Fixed thermal, fixed magnetic	<b>KDPVS3225W</b>	<b>CKDPVS3225W</b>
250	3	Fixed thermal, fixed magnetic	<b>KDPVS3250W</b>	<b>CKDPVS3250W</b>
300	3	Fixed thermal, fixed magnetic	<b>KDPVS3300W</b>	<b>CKDPVS3300W</b>
350	3	Fixed thermal, fixed magnetic	<b>KDPVS3350W</b>	<b>CKDPVS3350W</b>
400	3	Fixed thermal, fixed magnetic	<b>KDPVS3400W</b>	<b>CKDPVS3400W</b>

**Note**

<sup>①</sup> Terminals not included with frames.

# 2.6

## Molded Case Circuit Breakers

### Specialty Breakers

2

Catalog number includes breaker frame and trip unit. Order terminals separately. See **Page V4-T2-367**.

#### FD PV Frame



#### FD PV Frame, 100 A Maximum, 1000 Vdc, 3 kA ①

Current Rating Amperes	Poles in Series	Trip Unit	80% Rated	100% Rated
			Catalog Number	Catalog Number
30	4	Fixed thermal, fixed magnetic	FDPV4030W	CFDPV4030W
40	4	Fixed thermal, fixed magnetic	FDPV4040W	CFDPV4040W
50	4	Fixed thermal, fixed magnetic	FDPV4050W	CFDPV4050W
60	4	Fixed thermal, fixed magnetic	FDPV4060W	CFDPV4060W
70	4	Fixed thermal, fixed magnetic	FDPV4070W	CFDPV4070W
80	4	Fixed thermal, fixed magnetic	FDPV4080W	CFDPV4080W
90	4	Fixed thermal, fixed magnetic	FDPV4090W	CFDPV4090W
100	4	Fixed thermal, fixed magnetic	FDPV4100W	CFDPV4100W

#### KD PV Frame



#### KD PV Frame, 350 A Maximum, 1000 Vdc, 5 kA ①

Current Rating Amperes	Poles in Series	Trip Unit	80% Rated	100% Rated
			Catalog Number	Catalog Number
125	4	Fixed thermal, fixed magnetic	KDPV4125W	CKDPV4125W
150	4	Fixed thermal, fixed magnetic	KDPV4150W	CKDPV4150W
175	4	Fixed thermal, fixed magnetic	KDPV4175W	CKDPV4175W
200	4	Fixed thermal, fixed magnetic	KDPV4200W	CKDPV4200W
225	4	Fixed thermal, fixed magnetic	KDPV4225W	CKDPV4225W
250	4	Fixed thermal, fixed magnetic	KDPV4250W	CKDPV4250W
300	4	Fixed thermal, fixed magnetic	KDPV4300W	CKDPV4300W
350	4	Fixed thermal, fixed magnetic	KDPV4350W	CKDPV4350W

#### LG PV Frame



#### LG PV Frame, 400 A Maximum, 1000 Vdc, 5 kA ①

Current Rating Amperes	Poles in Series	Trip Unit	80% Rated	100% Rated
			Catalog Number	Catalog Number
250	4	Fixed thermal, fixed magnetic	LGPV4250W	CLGPV4250W
300	4	Fixed thermal, fixed magnetic	LGPV4300W	CLGPV4300W
350	4	Fixed thermal, fixed magnetic	LGPV4350W	CLGPV4350W
400	4	Fixed thermal, fixed magnetic	LGPV4400W	CLGPV4400W

#### MDL PV Frame



#### MDL PV Frame, 600 A Maximum, 1000 Vdc, 7.5 kA ①

Current Rating Amperes	Poles in Series	Trip Unit	80% Rated	100% Rated
			Catalog Number	Catalog Number
300	3	Fixed thermal, fixed magnetic	MDLPV3300W	CMDLPV3300W
350	3	Fixed thermal, fixed magnetic	MDLPV3350W	CMDLPV3350W
400	3	Fixed thermal, fixed magnetic	MDLPV3400W	CMDLPV3400W
450	3	Fixed thermal, fixed magnetic	MDLPV3450W	CMDLPV3450W
500	3	Fixed thermal, fixed magnetic	MDLPV3500W	CMDLPV3500W
600	3	Fixed thermal, fixed magnetic	MDLPV3600W	CMDLPV3600W

**Note**

① Terminals not included with frames.

## Accessories

### Available Accessories

- Auxiliary switch
- Shunt trip
- Electrical operator
- Alarm lockout
- Undervoltage release
- Terminals
- Lock-off devices
- End cap kits
- Rotary handle mechanisms
- Flexible shaft handle mechanisms

### Optional modifications

- Freeze testing

For complete internal and external accessories, see the accessory section of each frame.

### External Accessories

Description	Frame	Catalog Number
<b>Imperial Base Mounting Hardware</b>		
0.164-32 x 1.5-inch pan-head steel screws and lockwashers	FD PV	<b>BMH1</b>
0.250-20 x 1.5 inch pan-head steel screws and lockwashers	KD PV KD PVS	<b>BMH3</b>
—	JG PVS	N/A
—	LG PV	N/A
0.3125-18 x 1.25 inch filister-head steel screws and lockwashers and flat washers	MDL PV	<b>BMH5</b>
<b>Metric Base Mounting Hardware</b>		
M4-0.7 x 38 mm pan-head steel screws and lockwashers	FD PV	<b>BMH1M</b>
M6-0.7 x 38 mm pan-head steel screws and lockwashers	KD PV KD PVS	<b>BMH3M</b>
—	JG PVS	Included <sup>①</sup>
—	LG PV	Included <sup>①</sup>
M8-1.25 x 35 mm pan-head steel screws and lockwashers	MDL PV	<b>BMH5M</b>
<b>Interphase Barriers</b>		
	FD PV	<b>IPB1</b>
	KD PV KD PVS	<b>IPB3</b>
	JG PVS	<b>FJIPBK</b> <sup>②</sup>
	LG PV	<b>IPB3</b>
	MDL PV	<b>IPB4</b>
<b>Non-Padlockable Handle Block</b>		
	FD PV	<b>LKD1</b>
	KD PV KD PVS	<b>LKD3</b>
	JG PVS	N/A
	LG PV	N/A
	MDL PV	<b>LKD4</b>
<b>Padlockable Handle Lock Hasp</b> <sup>③</sup>		
	FD PV	<b>PLK1</b>
	KD PV KD PVS	<b>PLK3</b>
	JG PVS	<b>FJPHL</b>
	LG PV	<b>LPHL</b>
	MDL PV	<b>HLK4</b>

### Factory Modifications—Freeze Testing to –40°C <sup>④</sup>

Frame	Modification Code
FD PV	F01
JG PVS	F01
KD PV and KD PVS	F01
LG PV	F01
MDL PV	F01
Special calibration—contact Eaton for availability	

### Molded Case Switches

Eaton's DC molded case switches (MCS) are used in applications requiring a compact, high capacity disconnect. PVGuard 1000 Vdc

MCS are UL 489B listed and have automatic instantaneous current protection. These devices do not provide overload protection.

### Molded Case Switches

Maximum Continuous Ampere Rating at 50 °C	Interrupting Capacity Vdc	Poles in Series	Catalog Number
<b>1000 Vdc Maximum</b>			
100	3000	4	<b>FDPV4100KW</b>
200	5000	4	<b>KDPV4200KW</b>
250	5000	4	<b>KDPV4250KW</b>
350	5000	4	<b>KDPV4350KW</b>
400	5000	4	<b>LGPV4400KSW</b>
600	7500	3	<b>MDLPV3600KSW</b>

### Notes

- ① Base mounting hardware is included with a circuit breaker or a molded case switch (included with breaker). If required separately, order 66A2546G02.
- ② Individually priced.
- ③ Locks in ON and OFF position.
- ④ Add 20% to list price.

## Internal Accessories—Right Pole Mounting

	FD PV ①		JG PVS		KD PV KD PVS		LG PV		MDL PV	
	Factory Modification Code	Field Kit Catalog Number	Factory Modification Code	Field Kit Catalog Number	Factory Modification Code	Field Kit Catalog Number	Factory Modification Code	Field Kit Catalog Number	Factory Modification Code	Field Kit Catalog Number
<b>Auxiliary Switch</b>										
1A-1B	A06	A1X1PK	A1	AUX1A1BPK	A06	A1X3PK	A1	AUX1A1BPK	A06	A1X4PK
2A-2B	A13	A2X1RPK	A2	AUX2A2BPK	A13	A2X3PK	A2	AUX2A2BPK	A13	A2X4PK
<b>Alarm Switch</b>										
1 make/1 break	B06	A1L1RPK	B1	ALM1M1BJPKL	B06	A1L3RPK	B1	ALM1M1BJPK	B06	A1L4RPK
<b>Auxiliary and Alarm Combo</b>										
1A-1B, 1 make/1 break	C05	AAL1RPK	B2w	AUXALRMJPK	C05	AAL3RPK	B2	AUXALRMJPK	C05	AA114RPK

## Internal Accessories—Left Pole Mounting

	FD PV ①		JG PVS		KD PV KD PVS		LG PV		MDL PV	
	Factory Modification Code	Field Kit Catalog Number	Factory Modification Code	Field Kit Catalog Number	Factory Modification Code	Field Kit Catalog Number	Factory Modification Code	Field Kit Catalog Number	Factory Modification Code	Field Kit Catalog Number
<b>Shunt Trip</b>										
12 Vdc	S02	SNT1LP03K	S4	SNT012CPK	S42	SNT3P04K	S4	SNT012CPK	S02	SNT4LP03K
24 Vdc	S02	SNT1LP03K	S6	SNT024CPK	S42	SNT3P04K	S6	SNT024CPK	S02	SNT4LP03K
48 Vdc	S06	SNT1LP08K	S7	SNT4860CPK	S50	SNT3P06K	S7	SNT4860CPK	S86	SNT4LP23K
60 Vdc	S06	SNT1LP08K	S7	SNT4860CPK	S50	SNT3P06K	S7	SNT4860CPK	S86	SNT4LP23K
125 Vdc	S10	SNT1LP12K	S5	SNT125DPK	S10	SNT3P11K	S2	SNT120CPK	S42	SNT4LP26K
250 Vdc	S14	SNT1LP18K	—	—	S14	SNT3P14K	—	—	S14	SNT4LP14K
120 Vac	S10	SNT1LP12K	S2	SNT120CPK	S10	SNT3P11K	S2	SNT120CPK	S10	SNT4LP11K
<b>Undervoltage Release</b>										
12 Vdc	U30	UVH1LP20K	—	—	T02	UVH3LP20K	U1	UVR012DPK	T02	UVH4LP20K
24 Vdc	U34	UVH1LP21K	U2	UVR024CPK	T02	UVH3LP21K	U2	UVR024DPK	T06	UVH4LP21K
48 Vdc	U38	UVH1LP22K	U4	UVR048DPK	T10	UVH3LP22K	U4	UVR048DPK	T10	UVH4LP22K
60 Vdc	—	—	U4	UVR048DPK	—	—	—	—	—	—
125 Vdc	U42	UVH1LP26K	U6	UVR125DPK	T14	UVH3LP26K	U6	UVR125DPK	T14	UVH4LP26K
250 Vdc	U46	UVH1LP28K	U8	UVR250DPK	T18	UVH3LP28K	U8	UVR250DPK	T18	UVH4LP28K
120 Vac	U14	UVH1LP08K	U5	UVR120APK	U18	UVH3LP08K	U5	UVR120APK	U18	UVH4LP08K

**Notes**

① Underwriters Laboratories requires that internal accessories for the FD PV be installed at the factory. Internal accessories are UL listed for factory installation under E7819. Where local codes and standards permit and UL listing is not required, internal accessories can be field installed. Accessory installation should be done before the circuit breaker is mounted and connected.

One accessory can be mounted per pole, per breaker.

## PVGard Solar Circuit Breaker Terminal Offering

Breaker Frame	Maximum Breaker Ampacity	Terminal Body Material	Wire Type	AWG Wire Range/ Number of Conductors	Metric Wire Range mm <sup>2</sup>	Number of Terminals Included	Standard Terminal Catalog Number	Comments
FD PV	50	Steel	Cu/Al	14–4 (1)	2.5–25 (1)	3	<b>3TA50FB</b>	
	100	Aluminum	Cu/Al	6–300 kcmil (1)	16–150 (1)	3	<b>3TA225FDK3</b>	Includes 3P terminal cover
	100	Aluminum	Cu/Al	6–300 kcmil (1)	16–150 (1)	3	<b>3TA225FDK</b>	Includes 3P terminal cover Replacement use only
	100	Copper	Cu	4–4/0 (1)	25–95 (1)	3	<b>3T225FD</b>	
JG PVS	250	Aluminum	Cu/Al	#8–350 kcmil (1)	—	—	<b>TA250FJ</b>	
	250	Aluminum	Cu/Al	(2) 2/0–(2) 4/0	—	①	<b>3TA251FJK1</b>	
	250	Aluminum	Cu/Al	(2) 2/0–(2) 4/0	—	②	<b>3TA251FJK2</b>	
	250	Copper	Cu	#4–350 kcmil (1)	—	—	<b>T250FJ</b>	
KD PV KD PVS	225	Aluminum	Cu/Al	3–350 kcmil (1)	35–185 (1)	1	<b>TA300K</b>	
	250	Aluminum	Cu/Al	250–500 kcmil (1)	120–240 (1)	1	<b>TA350K</b>	
	250	Aluminum	Cu/Al	3/0–250 kcmil (2)	95–120 (1)	4	<b>4TA400K</b>	Contains interphase barriers
	250	Aluminum	Cu/Al	2/0–250 kcmil (2) or 2/0–500 kcmil (1)	70–240 (2)	4	<b>4TA401K</b>	
	300	Aluminum	Cu/Al	3/0–250 kcmil (2)	95–120 (2)	4	<b>4TA401K</b>	Contains interphase barriers
	350	Aluminum	Cu/Al	3/0–250 kcmil (2)	95–120 (2)	4	<b>4TA401K</b>	Contains interphase barriers
	225	Copper	Cu	3–350 kcmil (1)	35–185 (1)	1	<b>T300K</b>	
	250	Copper	Cu	250–500 kcmil (1)	120–240 (1)	1	<b>T350K</b>	
	250	Copper	Cu	3/0–250 kcmil (2)	95–120 (1)	4	<b>4T400K</b>	Contains interphase barriers
	300	Copper	Cu	3/0–250 kcmil (2)	95–120 (2)	4	<b>4TA401K</b>	Contains interphase barriers
LG PV	400	Aluminum	Cu/Al	2–500 kcmil (2)	35–240 (2)	4	<b>4TA632LK</b>	Includes 4P terminal cover
	250	Copper	Cu	2–500 kcmil (1)	35–240 (1)	1	<b>T350LK</b>	
	400	Copper	Cu	2–500 kcmil (2)	35–240 (2)	4	<b>4T632LK</b>	Includes 4P terminal cover
MDL PV	300	Aluminum	Cu/Al	1–500 kcmil (2)	—	1	<b>TA700MA1</b>	
	600	Aluminum	Cu/Al	3/0–400 kcmil (3)	—	1	<b>TA800MA2</b>	

## Endcap Kits

Breaker Frame	Number of Poles	Thread Type	Thread Size	Catalog Number
FD PV	4	Imperial	10–32	<b>KPEK14</b>
	4	Metric	M–5	<b>KPEKM14</b>
JG PVS	3	Imperial	—	<b>FJ3RTDK</b>
	3	Metric	—	<b>FJ3RTWK</b>
KD PV	4	Imperial	0.312–18	<b>KPEK34</b>
	4	Metric	M–8	<b>KPEKM34</b>
KD PVS	3	Imperial	—	<b>KPEK3</b>
	3	Metric	—	<b>KPEKM3</b>
LG PV	4	Imperial	—	<b>N/A</b>
	4	Metric	M-10	<b>L4RTWK</b>
MDL PV	3	Imperial	—	—
	3	Metric	—	—

## Notes

① Three terminals with terminal shield as a kit.

② Three terminals with two interphase barriers as a kit.

**Jumpers**

Jumpers must be ordered separately. Priced individually.

2

**FD PV Frame**

Description	Maximum Amperes	Catalog Number
Single copper jumper	60	DC1F060 <sup>①</sup>
	100	DC1F100 <sup>①</sup>
	125	DC1F125 <sup>①</sup>
	225	DC1F225 <sup>①</sup>
Package of 2 aluminum jumpers	100	DC2FD100A
Package of 3 aluminum jumpers	100	DC3FD100A

**JG PVM, JG PVMD Frames**

Description	Maximum Amperes	Catalog Number
Single aluminum jumper	250	DC1JG250A <sup>①</sup>
Package of 2 aluminum jumpers	250	DC2JG250A <sup>①</sup>
Package of 20 aluminum jumpers	250	DC20JG250A <sup>①</sup>

**KD PV, KD PVM, KD PVMD Frames**

Description	Maximum Amperes	Catalog Number
Single copper jumper	400	DC1K400 <sup>①</sup>
Package of 2 aluminum jumpers	400	DC2KD400A <sup>①</sup>
Package of 3 aluminum jumpers	400	DC3KD400A <sup>①</sup>

**LG PV Frame**

Description	Maximum Amperes	Catalog Number
Package of 2 aluminum jumpers	400	DC2LG400A
Package of 3 aluminum jumpers	400	DC3LG400A
Package of 30 aluminum jumpers	400	DC30LG400A

**Note**

<sup>①</sup> Not UL Listed; Non UL listed jumpers used in a UL application may need to be qualified by the OEM in their assembly. This may take place with UL or another certified testing agency.

**Technical Data and Specifications**

- Thermal-magnetic circuit breakers
- Designed to meet UL 489B for solar photovoltaic circuit protection
- 100% rated of the continuous current rating
- 50 °C calibrated
- Can be applied in grounded, ungrounded or bi-polar systems
- Ability to open on signal from DC arc or ground fault detector
- Two PVGard lineups
  - UL File EE350638, Category Control Number DIUR
  - 600 Vdc per-pole breaker and switch
    - Each pole rated 600 Vdc
  - 1000 Vdc poles-in-series breaker and switch
    - Requires poles in series connection

**Quick Reference PVGard Solar Circuit Breakers  
600 Vdc Per-Pole****PVGard 600 Vdc Current Ratings by Frame  
UL 489B Interrupting Capacity (kA) 600 Vdc Per-Pole**

Circuit Breaker Type	Minimum Amperes	Maximum Amperes	kA Rating
JG PVS	90	250	1.2
KD PVS	100	400	3

**Quick Reference PVGard Solar Circuit Breakers  
1000 Vdc Poles-in-Series****PVGard 1000 Vdc Current Ratings by Frame  
UL 489B Interrupting Capacity (kA) 1000 Vdc**

Circuit Breaker Type	Minimum Amperes	Maximum Amperes	kA Rating	Poles in Series
FD PV	30	100	3	4
KD PV	125	350	5	4
LG PV	250	400	5	4
MDL PV	300	600	7.5	3

# 2.6

## Molded Case Circuit Breakers

### Specialty Breakers

2

#### PVGard 600 Vdc Per-Pole Solar PV Circuit Breakers (100% and 80% Rated Frames)

	JG PVS	KD PVS
Number of 600 Vdc circuits	3	3
Maximum voltage rating	600 Vdc	600 Vdc
Ampere range	90–250 A	100–400 A
Interrupting capacity at 600 Vdc	1.2 kA	3 kA
Time constant	1 ms	1 ms
Trip unit type	Thermal-magnetic	Thermal-magnetic
Rated impulse withstand voltage		
Main conducting paths	8 kV	8 kV
Auxiliary circuits	4 kV	4 kV
Endurance		
Mechanical operations	10,000	6000
Electrical operations	400	400
Maximum switching frequency	240 per hour	240 per hour
Third-party certification	UL 489B	UL 489B
Environment		
Design ambient temperature	50 °C	50 °C
Maximum current at 60 °C, as % of rated current	93%	93%
Maximum current at 70 °C, as % of rated current	85%	85%
Operating temperature range	–20 °C to +50 °C	–20 °C to +50 °C
Storage temperature range	–20 °C to +70 °C	–20 °C to +70 °C
Suitable for freeze temperatures to –40 °C	Option	Option
Relative humidity	0 to 95% noncondensing	0 to 95% noncondensing
Suitable for reverse-feed applications	Yes	Yes

Mounting—permissible mounting position

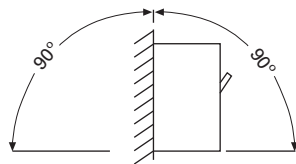

#### Connection diagrams

##### Terminations

Al/Cu wire	TA250FJ: (1) #8–350 kcmil	TA300K: (1) #3–350 kcmil
	3TA251FJK1: (2) 2/0–(2) 4/0 <sup>②</sup>	TA350K: (1) 250–500 kcmil
	3TA251FJK2: (2) 2/0–(2) 4/0 <sup>③</sup>	TA403K: (2) 1/0–400 kcmil
Cu wire	T250FJ: (1) #4–350 kcmil	3TA402K: (1) 500–750 kcmil <sup>④</sup>
	T300K: (1) #3–350 kcmil	

##### Dimensions in inches (mm)

Height	7.00 (177.8)	10.13 (257.3)
Width	4.13 (104.9)	5.50 (139.7)
Depth	3.57 (90.7)	4.10 (104.1)
Weight in lbs	6.6	11.42

#### Notes

- ① Three terminals with terminal shield as a kit.
- ② Three terminals with two interphase barriers as a kit.
- ③ Not UL 489B recognized size for maximum of 400 A breaker.

## PVGuard 1000 Vdc Solar PV Circuit Breakers (100% and 80% Rated Frames)

	FD PV	KD PV	LG PV	MDL PV
Number of poles	4	4	4	3
Maximum voltage rating	1000 Vdc	1000 Vdc	1000 Vdc	1000 Vdc
Maximum current rating	100 A	350 A	400 A	600 A
Interrupting capacity at 1000 Vdc	3 kA	5 kA	5 kA	7.5 kA
Time constant	1 ms	1 ms	1 ms	1 ms
Ampere range	15–100 A	125–350 A	250–400 A	300–600 A
Trip unit type	Thermal-magnetic	Thermal-magnetic	Thermal-magnetic	Thermal-magnetic
Rated impulse withstand voltage				
Main conducting paths	8 kV	8 kV	8 kV	8 kV
Auxiliary circuits	4 kV	4 kV	4 kV	4 kV
Endurance				
Mechanical operations	10,000	10,000	8000	8000
Electrical operations	1000	400	400	400
Maximum switching frequency	300 per hour	240 per hour	240 per hour	240 per hour
Third-party certification	UL 489B	UL 489B	UL 489B	UL 489B
Environment				
Design ambient temperature	50 °C	50 °C	50 °C	50 °C
Maximum current at 60 °C, as % of rated current	91%	91%	93%	93%
Maximum current at 70 °C, as % of rated current	88%	88%	88%	88%
Operating temperature range	–20 °C to +50 °C	–20 °C to +50 °C	–20 °C to +50 °C	–20 °C to +50 °C
Storage temperature range	–20 °C to +70 °C	–20 °C to +70 °C	–20 °C to +70 °C	–20 °C to +70 °C
Suitable for freeze temperatures to –40 °C	Option	Option	Option	Option
Relative humidity	0 to 95% noncondensing	0 to 95% noncondensing	0 to 95% noncondensing	0 to 95% noncondensing
Suitable for reverse-feed applications	Yes	Yes	Yes	Yes
Mounting—permissible mounting position				

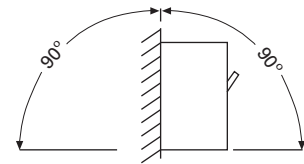
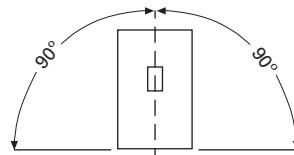

Connection diagrams

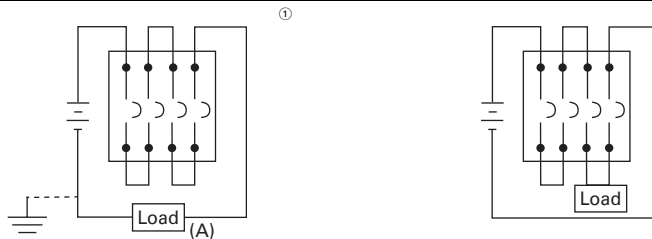

## Terminations

Al/Cu wire	#6–300 kcmil	(2) 3/0–250 kcmil	(2) #2–500 kcmil	(3) 3/0–400 kcmil
Cu wire	#4–4/0	(2) 3/0–250 kcmil	(2) #2–500 kcmil	(3) 3/0–300 kcmil
Dimensions in inches (mm)				
Height	6.00 (152.4)	10.13 (257.3)	10.13 (257.3)	16.00 (406.4)
Width	5.50 (139.7)	7.22 (183.4)	7.22 (183.4)	8.25 (209.5)
Depth	3.38 (85.9)	4.09 (103.9)	4.09 (103.9)	4.06 (103.1)
Weight in lbs	6	20	20	29

## Notes

- ① Suitable for use on ungrounded systems, or grounded systems that have one end of load (A) connected to grounded terminal, opposite poles in series connection.  
 ② Suitable for use on ungrounded systems only.

**Dimensions**

Approximate Dimensions in Inches (mm)

2

**PVGard Solar Circuit Breakers—600 Vdc Per-Pole**

Frame	Number of Circuits in a Frame	Width	Height	Depth
JG PVS	3	4.13 (104.9)	7.00 (177.8)	3.44 (87.4)
KD PVS	3	5.49 (139.4)	10.13 (257.2)	4.31 (109.6)

**PVGard Solar Circuit Breakers—1000 Vdc Poles-in-Series**

Frame	Number of Poles	Width	Height	Depth
FD PV	4	5.50 (139.7)	6.00 (152.4)	3.38 (86.0)
KD PV	4	7.22 (183.4)	10.13 (257.3)	4.09 (103.9)
LG PV	4	7.22 (183.4)	10.13 (257.3)	4.09 (103.9)
MDL PV	3	8.25 (209.6)	16.00 (406.4)	4.06 (103.1)

## Wiring Diagrams

### Series Connection Diagrams for DC Application ①②

#### JF PVS, KD PVS—600 Vdc Per-Pole

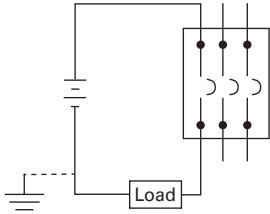

Suitable for grounded or ungrounded systems.  
Suitable for quantity (3) 600 Vdc circuits.

#### FD PV, KD PV, LG PV—1000 Vdc Maximum—Four Poles-in-Series

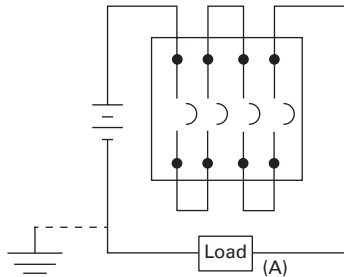

Suitable for use on ungrounded systems, or grounded systems that have one end of load (A) connected to grounded terminal, opposite poles in series connection.

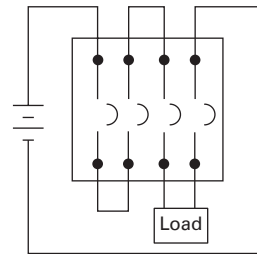

Suitable for use on ungrounded systems only.

#### MDL PV—1000 Vdc Maximum—Three Poles in Series

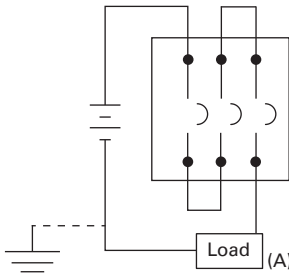

Suitable for use on ungrounded systems, or grounded systems that have one end of load (A) connected to grounded terminal, opposite poles in series connection.

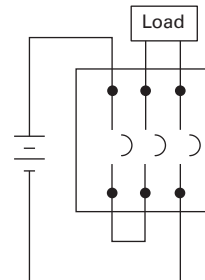

Suitable for use on ungrounded systems only.

#### Notes

- ① Poles in series connection is customer supplied. Use rated cable per NEC.
- ② For grounded systems, all poles in series must be connected on non-grounded terminal, with load connected to grounded terminal.

#### E<sup>2</sup> Mining Service Breakers

2



### E<sup>2</sup> Mining Service Breakers

#### Product Overview

State-of-the-art E<sup>2</sup> mining service breakers incorporate the rigid specifications and testing procedures developed by a focus group led by engineers from several large coal companies and Eaton design engineers. Additionally, the performance of these breakers was proven and verified during hundreds of hours of field testing in harsh mine environments.

E<sup>2</sup> mining breakers are available in 600 Vac, I000Y/577 Vac and 1200 Vac. Interchangeable trip units can be used on either 600 or 1000 Vac frames.

The E<sup>2</sup> mining breaker family is designed especially for trailing cable application per MSHA 30 CFR 75. Field interchangeable electronic rms sensing trip units are available from 150 to 2000 amperes with instantaneous pickup settings conforming to the code of Federal Regulations 30 CFR 75.601-2. Electromechanical trip units are also available with a wide range of magnetic pickup ranges.

E<sup>2</sup> electronic trip units are the first to provide the mining industry with true rms sensing, made possible by the custom ASIC microprocessor in each electronic trip unit.

E<sup>2</sup> breakers are designed to be physically and electrically interchangeable with Classic Mining Service Breakers and supersede Series C<sup>®</sup> Mining Service Breakers. The table to the right outlines direct replacements.

### Contents

#### Description

	<i>Page</i>
Engine Generator Circuit Breakers . . . . .	<b>V4-T2-341</b>
Direct Current Circuit Breakers . . . . .	<b>V4-T2-347</b>
PVGard Solar Circuit Breakers—600 Vdc Per-Pole and 1000 Vdc Poles-in-Series . . . . .	<b>V4-T2-361</b>
E <sup>2</sup> Mining Service Breakers	
Catalog Number Selection . . . . .	<b>V4-T2-376</b>
Product Selection . . . . .	<b>V4-T2-380</b>
Accessories . . . . .	<b>V4-T2-391</b>
Dimensions . . . . .	<b>V4-T2-394</b>
E2VAC Mining Vacuum Circuit Breaker . . . . .	<b>V4-T2-400</b>
Classic Mining Breakers . . . . .	<b>V4-T2-403</b>
Add-On Ground Fault Protection—Type GFR . . . . .	<b>V4-T2-417</b>

#### 600 Vac Mining Breaker Replacement Chart

Classic	Series C	E <sup>2</sup>
FBM	FDBM	E <sup>2</sup> F
HFBM	FDM	E <sup>2</sup> F
	HFDM (mag. only)	E <sup>2</sup> F
—	JDM	E <sup>2</sup> J
KAM	KDM	E <sup>2</sup> K
KAMH	KDM	E <sup>2</sup> K
LAM	LDM	E <sup>2</sup> L
LAMH	LDM	E <sup>2</sup> L
LCM	LDM	E <sup>2</sup> L
LCMH	LDM	E <sup>2</sup> L
MAM	—	E <sup>2</sup> M
MAMH	—	E <sup>2</sup> M
MCM	—	E <sup>2</sup> M
MCMH	—	E <sup>2</sup> M
NBM	—	E <sup>2</sup> N
NBMH	—	E <sup>2</sup> N
NCM	—	E <sup>2</sup> N
NCMH	—	E <sup>2</sup> N

#### 1000 Vac Mining Breaker Replacement Chart

Classic	Series C	E <sup>2</sup> M
HFM	—	E <sup>2</sup> FM
—	JDCM	E <sup>2</sup> JM
HKAM	KDCM	E <sup>2</sup> KM
HLAM	LDCM	E <sup>2</sup> LM
HLCM	LDCM	E <sup>2</sup> LM
HMAM	—	E <sup>2</sup> MM
HMCM	—	E <sup>2</sup> MM
HNBM	—	E <sup>2</sup> NM
HNBMH	—	E <sup>2</sup> NM
HNCM	—	E <sup>2</sup> NM
HLCLM	—	E <sup>2</sup> NM
HPBM	—	E <sup>2</sup> RM ①

#### Additional Information on Mining Breakers

Source	Description
TD01217001E	E <sup>2</sup> Mining Circuit Breaker Dimensional Data
BR01217001E	E <sup>2</sup> Mining Circuit Breaker Brochure
TC01217001E	E <sup>2</sup> Mining Circuit Breaker Time Current Curves
www.eaton.com/mining	Mining and Metals

#### Note

① E<sup>2</sup>R/E<sup>2</sup>RM is a new frame physically different than the HPBM. See DS29-170MS.

Eaton's mining service circuit breakers provide short-circuit protection as specified in the code of Federal Regulations 30 CFR 75.601-2.

E<sup>2</sup> 225/400 A K frame and 400/600 A L frame electronic trip units feature specifically designed instantaneous pickup settings to conform exactly with the code of Federal Regulations 30 CFR 75.601-2. Electromechanical trip units are also available with a wide range of magnetic pickup ranges.

The tables below list the conductor size maximum allowable circuit breaker instantaneous setting and the E<sup>2</sup> breaker that meets that setting.

### Interrupting Capacity Rating

Circuit Breaker Type	Interrupting Capacity (Symmetrical kA)					Vdc <sup>①</sup> 250
	Vac (50/60 Hz)					
	240	480	600	1000Y/577	1200	
E <sup>2</sup> F	65	35	18	—	—	10
E <sup>2</sup> J	65	35	18	—	—	10
E <sup>2</sup> K	65	35	25	—	—	10
E <sup>2</sup> LME	100	65	35	—	—	42
E <sup>2</sup> L	65	35	25	—	—	22
E <sup>2</sup> M	65	35	25	—	—	22
E <sup>2</sup> N	65	50	25	—	—	—
E <sup>2</sup> R	125	65	50	—	—	—
E <sup>2</sup> FM	65	25	18	10	—	10
E <sup>2</sup> JM	65	35	18	10	—	22
E <sup>2</sup> KM	65	35	25	14	—	10
E <sup>2</sup> LMZ	100	65	35	10	—	42
E <sup>2</sup> LM	—	35	25	18	—	22
E <sup>2</sup> MM	—	35	25	18	—	22
E <sup>2</sup> NM <sup>②</sup>	—	50	25	25	—	—
E <sup>2</sup> RM	—	65	50	25	—	—
E <sup>2</sup> KW	—	—	—	10	10	—
E <sup>2</sup> LW	—	—	—	10	10	—
E <sup>2</sup> MW	—	—	—	12	12	—

### Trailing Cable Setting Per 30 CFR 75

Conductor Size	Maximum Breaker Instantaneous Setting	Maximum Ampere 75 °C Insulated Conductor	E <sup>2</sup> /E <sup>2</sup> M/E <sup>2</sup> W Instantaneous Only	Setting
14	50	15	E <sup>2</sup> K 150 A	A
12	75	20	E <sup>2</sup> K 150 A	B
10	150	30	E <sup>2</sup> K 150 A	C
8	200	50	E <sup>2</sup> K 225 A	A
6	300	65	E <sup>2</sup> K 225 A	B
4	500	85	E <sup>2</sup> K 225 A / E2L 400 A	C/A
3	600	100	E <sup>2</sup> K 225 A / E2L 400 A	D/B
2	800	115	E <sup>2</sup> K 225 A / E2L 400 A	E/C
1	1000	130	E <sup>2</sup> K 225 A / E2L 400 A	F/D
1/0	1250	150	E <sup>2</sup> K 225 A / E2L 400 A	G/E
2/0	1500	175	E <sup>2</sup> K 225 A / E2L 400 A	H/F
3/0	2000	200	E <sup>2</sup> L 400 A	G
4/0	2500	230	E <sup>2</sup> L 400 A	H
250	2500	255	E <sup>2</sup> L 400 A	H
300	2500	285	E <sup>2</sup> L 400 A	H
350	2500	310	E <sup>2</sup> L 400 A	H
400	2500	335	E <sup>2</sup> L 400 A	H
500	2500	380	E <sup>2</sup> L 400 A	H

### Auxiliary Switch Electrical Rating Data

Maximum Voltage	Frequency	Maximum Current Amperes
600	50/60 Hz	6.0
125	DC	0.5 (non-inductive load)
250	DC	0.25 (non-inductive load)

### Alarm (Signal/Lockout Switch) Electrical Rating Data

Maximum Voltage	Frequency	Maximum Current Amperes
600	50/60 Hz	6.0
125	DC	0.5 (non-inductive load)
250	DC	0.25 (non-inductive load)

#### Notes

- ① Two poles in series. DC rating applies to breakers with thermal-magnetic trip unit. Breakers with electronic trip units are not DC rated.
- ② Series rated for application with Eaton's E<sup>2</sup>KM and E<sup>2</sup>LM breakers.

# 2.6

## Molded Case Circuit Breakers

### Specialty Breakers

#### Catalog Number Selection

This information is presented only as an aid to understanding catalog numbers. It is not to be used to build catalog numbers for circuit breakers or trip units.

2

#### E<sup>2</sup> Mining Service Breaker with 310+ Electronic Trip Unit Technology

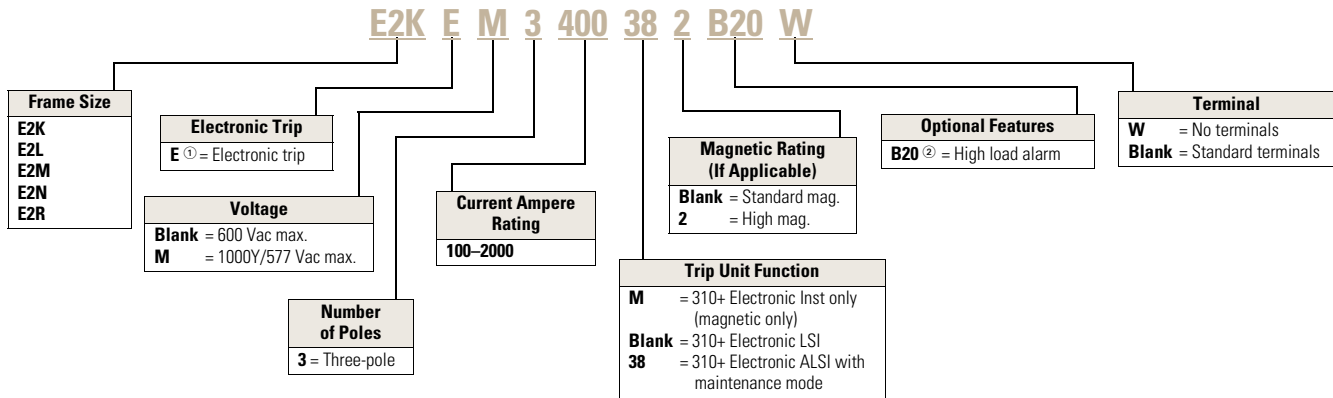

#### E<sup>2</sup> Mining Service 310+ Electronic Trip Unit

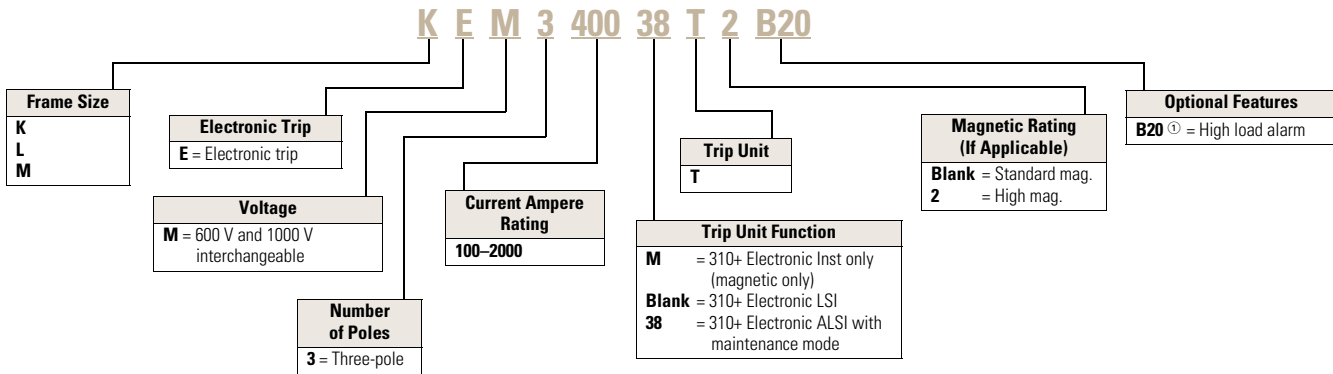

#### Notes

- ① All N- and R-Frame breakers equipped with 310+ Electronic Trip Unit. No "E" suffix required.
- ② Not available with instantaneous only.

**E<sup>2</sup> Mining Service Breaker Frame Only** ①

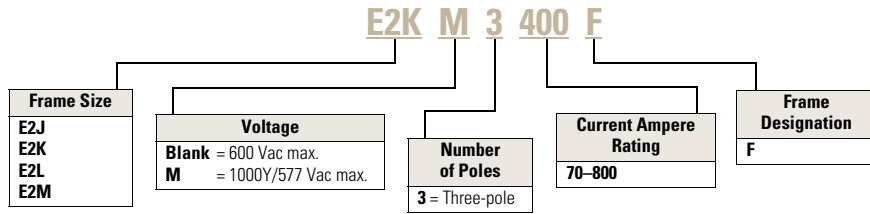

**E<sup>2</sup> Mining Service Breaker with Thermal-Magnetic Trip Unit** ①

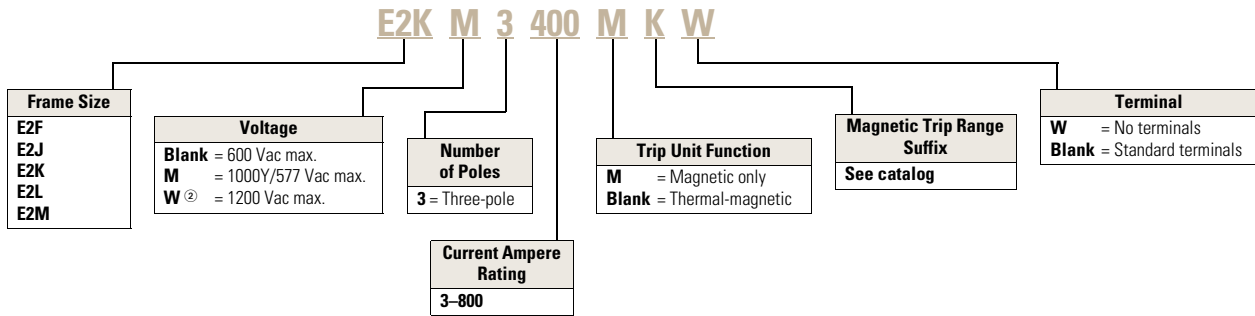

**E<sup>2</sup> Mining Service Thermal-Magnetic Trip Unit** ①

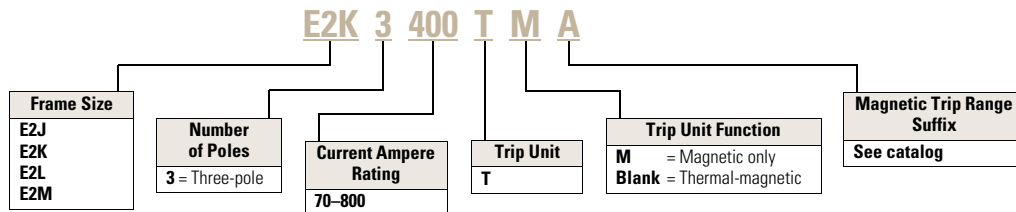

**Notes**

- ① Does not apply to E2LME/LMZ.
- ② Only available in K-, L- and M-Frames.

## Undervoltage Release Mechanism Electrical Rating Data

2

Breaker Type	Supply Voltage	Dropout Voltage		Pickup Voltage Maximum	VA
		Minimum	Maximum		
E <sup>2</sup> F/E <sup>2</sup> FM	110 Vac	44.5	77	93.5	1.3
	120 Vac				1.5
	127 Vac				1.7
	110 Vdc				1.5
	120 Vdc				1.7
	125 Vdc				1.9
E <sup>2</sup> J/E <sup>2</sup> JM	110 Vac	44.5	77	93.5	1.8
	120 Vac				2.1
	127 Vac				2.4
	110 Vdc				1.6
	120 Vdc				1.9
	125 Vdc				2.2
E <sup>2</sup> K/E <sup>2</sup> KM/E <sup>2</sup> KW	110 Vac	44.5	77	93.5	1.8
	120 Vac				2.1
	127 Vac				2.4
	110 Vdc				1.6
	120 Vdc				1.9
	125 Vdc				2.2
E <sup>2</sup> LME/E <sup>2</sup> LMZ	110 Vac	44.5	77	93.5	0.96
	120 Vac				1.13
	127 Vac				1.25
	110 Vdc	43.8	77	93.5	0.94
	120 Vdc				1.12
	125 Vdc				1.21
E <sup>2</sup> L/E <sup>2</sup> LM/E <sup>2</sup> LW/E <sup>2</sup> M/ E <sup>2</sup> MM/E <sup>2</sup> MW	110 Vac	44.5	77	93.5	1.8
	120 Vac				2.1
	127 Vac				2.4
	110 Vdc				1.6
	120 Vdc				1.9
	125 Vdc				2.2
E <sup>2</sup> N/E <sup>2</sup> NM	110 Vac	44.5	77	93.5	1.8
	120 Vac				2.1
	127 Vac				2.4
	110 Vdc				1.6
	120 Vdc				1.9
	125 Vdc				2.2
E <sup>2</sup> R/E <sup>2</sup> RM	110 Vac	44.5	77	93.5	3.3
	120 Vac				3.6
	127 Vac				3.8
	110 Vdc	43.8	77	93.5	3.3
	120 Vdc				3.6
	125 Vdc				3.8

## Shunt Trip Electrical Rating Data

Breaker Type	Supply Voltage	Operating Voltage		
		Minimum	VA	
E <sup>2</sup> F/E <sup>2</sup> FM	48 Vac	33.6	92	
	60 Vac		140	
	110 Vac		480	
	120 Vac		570	
	127 Vac		640	
	208 Vac	146	180	
	220 Vac		200	
	230 Vac		240	
	48 Vdc		33.6	100
	60 Vdc			160
	110 Vdc	77		55
	120 Vdc			66
	125 Vdc			71
	E <sup>2</sup> J/E <sup>2</sup> JM		110 Vac	60.5
		120 Vac	84	
127 Vac		102		
110 Vdc		77	112	
120 Vdc			138	
125 Vdc	150			
E <sup>2</sup> K/E <sup>2</sup> KM/E <sup>2</sup> KW	110 Vac	60	100	
	120 Vac		120	
	127 Vac		140	
	110 Vdc	77	110	
	120 Vdc		130	
	125 Vdc		140	
	24 Vac		41	
	48 Vac	18	139	
	60 Vac		210	
E <sup>2</sup> LME/E <sup>2</sup> LMZ	110 Vac	60	83	
	120 Vac		92	
	127 Vac		117	
	24 Vdc		120	
	48 Vdc	18	475	
	60 Vdc		720	
	110 Vdc		82	99
	120 Vdc	120		
	125 Vdc	121		

Breaker Type	Supply Voltage	Operating Voltage	
		Minimum	VA
E <sup>2</sup> L/E <sup>2</sup> LM/E <sup>2</sup> LW/E <sup>2</sup> M/ E <sup>2</sup> MM/E <sup>2</sup> MW	48 Vac	34	830
	60 Vac		1280
	110 Vac	60	100
	120 Vac		120
	127 Vac		140
	48 Vdc	34	710
	60 Vdc		1105
	110 Vdc		77
	120 Vdc	130	
	125 Vdc	140	
E <sup>2</sup> N/E <sup>2</sup> NM	110 Vac	60	
	120 Vac		120
	127 Vac		140
	110 Vdc	77	110
	120 Vdc		130
125 Vdc	140		
E <sup>2</sup> R/E <sup>2</sup> RM	110 Vac	60.5	330
	120 Vac		390
	127 Vac		430
	110 Vdc	77	370
	120 Vdc		440
125 Vdc	480		

# 2.6

## Molded Case Circuit Breakers

### Specialty Breakers

#### Product Selection

3 A–150 A

E<sup>2</sup>F/E<sup>2</sup>FM

2

E<sup>2</sup>F/E<sup>2</sup>FM



#### Sealed Breakers with Non-Interchangeable Trip Unit—Include Line/Load Terminals, Non-Electronic Trip Units <sup>①</sup>

Maximum Continuous Ampere Rating at 40 °C	Magnetic Trip Range	Trip Unit Only Catalog Number	600 Vac Maximum 250 Vdc 35 kA at 480 Vac Three-Pole	1000Y/ 577 Vac Maximum 250 Vdc 10 kA at 1000 Vac Three-Pole
			Complete Breaker Catalog Number	Complete Breaker Catalog Number
<b>Thermal-Magnetic</b>				
15	—	—	E2F3015	—
20	—	—	E2F3020	E2FM3020
25	—	—	E2F3025	E2FM3025
30	—	—	E2F3030	—
35	—	—	E2F3035	—
40	—	—	E2F3040	E2FM3040
45	—	—	E2F3045	—
50	—	—	E2F3050	E2FM3050
60	—	—	E2F3060	E2FM3060
70	—	—	E2F3070	E2FM3070
80	—	—	E2F3080	E2FM3080
90	—	—	E2F3090	E2FM3090
100	—	—	E2F3100	E2FM3100
125	—	—	E2F3125	E2FM3125
150	—	—	E2F3150	E2FM3150
<b>Magnetic Only</b>				
3	9–30	—	E2F003AM	—
7	21–70	—	E2F007CM	—
15	45–150	—	E2F015EM	—
30	90–300	—	E2F030HM	—
	50–150	—	E2F030EM	—
50	150–500	—	E2F050KM	E2FM050KM
	66–190	—	E2F050YM	E2FM050YM
70	210–700	—	E2F070MM	E2FM070MM
100	150–500	—	E2F100KM	E2FM100KM
	300–1000	—	E2F100RM	E2FM100RM
150	450–1500	—	E2F150TM	E2FM150TM
	750–2500	—	E2F150UM	E2FM150UM

**Note**

<sup>①</sup> For two-pole application, use outer poles.

70 A–250 A

E<sup>2</sup>J/E<sup>2</sup>JME<sup>2</sup>J/E<sup>2</sup>JM

## Circuit Breakers with Interchangeable Non-Electronic Trip Units

Maximum Continuous Ampere Rating at 40 °C	Magnetic Trip Range	Trip Unit Only Catalog Number	600 Vac Maximum 250 Vdc 35 kA at 480 Vac Three-Pole ①	1000V/ 577 Vac Maximum 250 Vdc 10 kA at 1000 Vac Three-Pole ②
			Complete Breaker Catalog Number	Complete Breaker Catalog Number
<b>Thermal-Magnetic</b>				
70	300–650	E2J3070T	E2J3070W	E2JM3070W
90	450–900	E2J3090T	E2J3090W	E2JM3090W
100	500–1000	E2J3100T	E2J3100W	E2JM3100W
125	625–1250	E2J3125T	E2J3125W	E2JM3125W
150	750–1500	E2J3150T	E2J3150W	E2JM3150W
175	875–1750	E2J3175T	E2J3175W	E2JM3175W
200	1000–2000	E2J3200T	E2J3200W	E2JM3200W
225	300–650	E2J3225TA	E2J3225AW	E2JM3225AW
	500–1000	E2J3225TD	E2J3225DW	E2JM3225DW
	1125–2250	E2J3225T	E2J3225W	E2JM3225W
250	1250–2500	E2J3250T	E2J3250W	E2JM3250W
<b>Magnetic Only</b>				
250	300–650	E2J3250TMA	E2J3250MAW	E2JM3250MAW
	450–900	E2J3250TMC	E2J3250MCW	E2JM250MCW
	500–1000	E2J3250TMD	E2J3250MDW	E2JM3250MDW
	625–1250	E2J3250TMF	E2J3250MFW	E2JM3250MFW
	750–1500	E2J3250TMG	E2J3250MGW	E2JM3250MGW
	875–1750	E2J3250TMJ	E2J3250MJW	E2JM3250MJW
	1000–2000	E2J3250TMK	E2J3250MKW	E2JM3250MKW
	1125–2250	E2J3250TML	E2J3250MLW	E2JM3250MLW
	1250–2500	E2J3250TM	E2J3250MW	E2JM3250MW

**Notes**

- ① Frame only: **E2J3250F**.  
 ② Frame only: **E2JM3250F**.

# 2.6

## Molded Case Circuit Breakers

### Specialty Breakers

100 A–400 A

E<sup>2</sup>K/E<sup>2</sup>KM/E<sup>2</sup>KW

2

E<sup>2</sup>K/E<sup>2</sup>KM



#### Circuit Breakers with Interchangeable Non-Electronic Trip Units

Maximum Continuous Ampere Rating at 40 °C	Magnetic Trip Range	Trip Unit Only Catalog Number	600 Vac Maximum 250 Vdc 35 kA at 480 Vac Three-Pole ① Complete Breaker Catalog Number	1000V/ 577 Vac Maximum 250 Vdc 14 kA at 1000 Vac Three-Pole ② Complete Breaker Catalog Number	1200 Vac Maximum 10 kA at 1200 Vac Three-Pole ③④ Complete Breaker Catalog Number
<b>Thermal-Magnetic</b>					
100	500–1000	E2K3100T	E2K3100W	E2KM3100W	E2KW3100W
125	625–1250	E2K3125T	E2K3125W	E2KM3125W	E2KW3125W
150	750–1500	E2K3150T	E2K3150W	E2KM3150W	E2KW3150W
175	875–1750	E2K3175T	E2K3175W	E2KM3175W	E2KW3175W
200	1000–2000	E2K3200T	E2K3200W	E2KM3200W	E2KW3200W
225	300–650	E2K3225TA	E2K3225AW	E2KM3225AW	E2KW3225AW
	500–1000	E2K3225TD	E2K3225DW	E2KM3225DW	E2KW3225DW
	1125–2250	E2K3225T	E2K3225W	E2KM3225W	E2KW3225W
250	1250–2500	E2K3250T	E2K3250W	E2KM3250W	E2KW3250W
300	1500–3000	E2K3300T	E2K3300W	E2KM3300W	E2KW3300W
320	1600–3200	—	—	—	E2KW3320W
350	1750–3500	E2K3350T	E2K3350W	E2KM3350W	E2KW3350W
400	2000–4000	E2K3400T	E2K3400W	E2KM3400W	—
<b>Magnetic Only</b>					
400	300–650	E2K3400TMA	E2K3400MAW	E2KM3250MAW	E2KW3250MAW
	500–1000	E2K3400TMD	E2K3400MDW	E2KM3400MDW	E2KW3350MDW
	625–1250	E2K3400TMF	E2K3400MFW	E2KM3400MFW	E2KW3350MFW
	750–1500	E2K3400TMG	E2K3400MGW	E2KM3400MGW	E2KW3350MGW
	875–1750	E2K3400TMJ	E2K3400MJW	E2KM3400MJW	E2KW3350MJW
	1000–2000	E2K3400TMK	E2K3400MKW	E2KM3400MKW	E2KW3350MKW
	1125–2250	E2K3400TML	E2K3400MLW	E2KM3400MLW	E2KW3350MLW
	1250–2500	E2K3400TMW	E2K3400MWW	E2KM3400MWW	E2KW3350MWW
	1500–3000	E2K3400TMN	E2K3400MNW	E2KM3400MNW	E2KW3350MNW
	1600–3200	—	—	—	E2KW3350MVW
	1750–3500	E2K3400TMR	E2K3400MRW	E2KM3400MRW	E2KW3350MRW
	2000–4000	E2K3400TM	E2K3400MW	E2KM3400MW	—

**Notes**

- ① Frame only: **E2K3400F**.
- ② Frame only: **E2KM3400F**.
- ③ 1200 V breakers are sold as “complete breakers” only.
- ④ Maximum continuous ampere rating at 50 °C.

Please see TD01217001E for detailed dimensions.

100 A–400 A

E<sup>2</sup>KE/E<sup>2</sup>KEME<sup>2</sup>KM

## Circuit Breakers with Interchangeable Electronic Trip Units

Maximum Continuous Ampere Rating at 40 °C	Magnetic Trip Range	Trip Unit Only Catalog Number	600 Vac Maximum 250 Vdc 35 kA at 480 Vac Three-Pole ①	1000Y/ 577 Vac Maximum 250 Vdc 14 kA at 1000 Vac Three-Pole ②
			Complete Breaker Catalog Number	Complete Breaker Catalog Number
<b>310+ Electronic Instantaneous Only</b>				
150	50–800	KEM3150TM	E2KE3150MW	E2KEM3150MW
225	200–1500	KEM3225TM	E2KE3225MW	E2KEM3225MW
	500–2500	KEM3225TM2	E2KE3225M2W	E2KEM3225M2W
400	200–1500	KEM3400TM	E2KE3400MW	E2KEM3400MW
	500–2500	KEM3400TM2	E2KE3400M2W	E2KEM3400M2W
<b>310+ Electronic LSI ③</b>				
100	50–800	KEM3100T	E2KE3100W	E2KEM3100W
125	50–800	KEM3125T	E2KE3125W	E2KEM3125W
150	50–800	KEM3150T	E2KE3150W	E2KEM3150W
200	200–1500	KEM3200T	E2KE3200W	E2KEM3200W
225	200–1500	KEM3225T	E2KE3225W	E2KEM3225
	500–2500	KEM3225T2	E2KE32252W	E2KEM32252W
400	200–1500	KEM3400T	E2KE3400W	E2KEM3400W
	500–2500	KEM3400T2	E2KE34002W	E2KEM34002W
<b>310+ Electronic ALSI with Maintenance Mode ③</b>				
100	50–800	KEM310038T	E2KE310038W	E2KEM310038W
125	50–800	KEM312538T	E2KE312538W	E2KEM312538W
150	50–800	KEM315038T	E2KE315038W	E2KEM315038W
200	200–1500	KEM320038T	E2KE320038W	E2KEM320038W
225	200–1500	KEM322538T	E2KE322538W	E2KEM322538
	500–2500	KEM322538T2	E2KE3225238W	E2KEM3225238W
400	200–1500	KEM340038T	E2KE340038W	E2KEM340038W
	500–2500	KEM340038T2	E2KE3400238W	E2KEM3400238W

**Notes**① Frame only: **E2K3400F**.② Frame only: **E2KM3400F**.③ For High Load Alarm option (B20): **E2KE340038B20W, KEM3400TB20**.

Please see TD01217001E for detailed dimensions.

# 2.6

## Molded Case Circuit Breakers

### Specialty Breakers

#### 160 A–400 A

#### E<sup>2</sup>LME/E<sup>2</sup>LMZ (Series G)

2

#### Circuit Breakers

Maximum Continuous Ampere Rating at 40 °C	Magnetic Trip Range	Trip Unit Only Catalog Number	600 Vac Maximum 250 Vdc 35 kA at 480 Vac Three-Pole ①	1000V/ 577 Vac Maximum 250 Vdc 14 kA at 1000 Vac Three-Pole ②
			Complete Breaker Catalog Number	Complete Breaker Catalog Number
<b>Magnetic Only</b>				
400	3600–4400	LT3400KM	E2LME3400KMW	E2LMZ3400KMW
<b>Interchangeable Electronic Trip Unit</b>				
160	320–1920	LT340031M	E2LME340031W	E2LMZ340031W
200	400–2400	LT340031M	E2LME340031W	E2LMZ340031W
225	450–2700	LT340031M	E2LME340031W	E2LMZ340031W
250	500–3000	LT340031M	E2LME340031W	E2LMZ340031W
300	600–3600	LT340031M	E2LME340031W	E2LMZ340031W
315	630–3780	LT340031M	E2LME340031W	E2LMZ340031W
350	700–4200	LT340031M	E2LME340031W	E2LMZ340031W
400	800–4800	LT340031M	E2LME340031W	E2LMZ340031W

#### Notes

① Frame only: **E2LME3400NN**.

② Frame only: **E2LMZ3400NN**.

Please see TD01217001E for detailed dimensions.

## 300 A–600 A

E<sup>2</sup>L/E<sup>2</sup>LM/E<sup>2</sup>LW

## Circuit Breakers with Interchangeable Non-Electronic Trip Units

Maximum Continuous Ampere Rating at 40 °C	Magnetic Trip Range	Trip Unit Only Catalog Number	600 Vac Maximum 250 Vdc 35 kA at 480 Vac Three-Pole ①	1000Y/ 577 Vac Maximum 250 Vdc 18 kA at 1000 Vac Three-Pole ②	1200 Vac Maximum 10 kA at 1200 Vac Three-Pole ③
			Complete Breaker Catalog Number	Complete Breaker Catalog Number	Complete Breaker Catalog Number
<b>Thermal-Magnetic</b>					
300	1500–3000	E2L3300T	E2L3300W	E2LM3300W	E2LW3300W
320	2250–4500	E2L3450T	E2L3450W	E2LM3450W	E2LW3320W
350	1600–3200	—	—	—	E2LW3350W
400	1750–3500	E2L3350T	E2L3350W	E2LM3350W	E2LW3400W
450	2000–4000	E2L3400T	E2L3400W	E2LM3400W	E2LW3450W
500	2500–5000	E2L3500T	E2L3500W	E2LM3500W	—
600	3000–6000	E2L3600T	E2L3600W	E2LM3600W	—
	1125–2250	E2L3600TL ④	—	—	—
<b>Magnetic Only</b>					
450	1600–3200	—	—	—	E2LW3450MVW
	1125–2250	—	—	—	E2LW3450MLW
	1500–3000	—	—	—	E2LW3450MNW
	1750–3500	—	—	—	E2LW3450MRW
	2000–4000	—	—	—	E2LW3450MXW
	2250–4500	—	—	—	E2LW3450MYW
600	1125–2250	E2L3600TML	E2L3600MLW	E2LM3600MLW	—
	1500–3000	E2L3600TMN	E2L3600MNW	E2LM3600MNW	—
	1750–3500	E2L3600TMR	E2L3600MRW	E2LM3600MRW	—
	2000–4000	E2L3600TMX	E2L3600MXW	E2LM3600MXW	—
	2250–4500	E2L3600TMY	E2L3600MYW	E2LM3600MYW	—
	2500–5000	E2L3600TMP	E2L3600MPW	E2LM3600MPW	—
	3000–6000	E2L3600TM	E2L3600MW	E2LM3600MW	—

**Notes**

① Frame only: E2L3600F.

② Frame only: E2LM3600F.

③ Maximum continuous ampere rating at 50 °C.

④ 600 A thermal 1125–2250 T.A.

Please see TD01217001E for detailed dimensions.

# 2.6

## Molded Case Circuit Breakers

### Specialty Breakers

300 A–600 A

E<sup>2</sup>LE/E<sup>2</sup>LEM

2

E<sup>2</sup>LM



#### Circuit Breakers with Interchangeable Electronic Trip Units

Maximum Continuous Ampere Rating at 40 °C	Magnetic Trip Range	Trip Unit Only Catalog Number	600 Vac Maximum 250 Vdc 35 kA at 480 Vac Three-Pole ①	1000Y/ 577 Vac Maximum 250 Vdc 18 kA at 1000 Vac Three-Pole ②
			Complete Breaker Catalog Number	Complete Breaker Catalog Number
<b>310+ Electronic Instantaneous Only</b>				
400	500–2500	LEM3400TM	E2LE3400MW	E2LEM3400MW
	1000–4000	LEM3400TM2	E2LE3400M2W	E2LEM3400M2W
600	500–2500	LEM3600TM	E2LE3600MW	E2LEM3600MW
	2500–5000	LEM3600TM2	E2LE3600M2W	E2LEM3600M2W
<b>310+ Electronic LSI ③</b>				
300	500–2500	LEM3300T	E2LE3300W	E2LEM3300W
350	500–2500	LEM3350T	E2LE3350W	E2LEM3350W
400	500–2500	LEM3400T	E2LE3400W	E2LEM3400W
	1000–4000	LEM3400T2	E2LE34002W	E2LEM34002W
600	500–2500	LEM3600T	E2LE3600W	E2LEM3600W
	2500–5000	LEM3600T2	E2LE36002W	E2LEM36002W
<b>310+ Electronic ALSI with Maintenance Mode ③</b>				
300	500–2500	LEM330038T	E2LE330038W	E2LEM330038W
350	500–2500	LEM335038T	E2LE335038W	E2LEM335038W
400	500–2500	LEM340038T	E2LE340038W	E2LEM340038W
	1000–4000	LEM340038T2	E2LE3400238W	E2LEM3400238W
600	500–2500	LEM360038T	E2LE360038W	E2LEM360038W
	2500–5000	LEM360038T2	E2LE3600238W	E2LEM3600238W

**Notes**

- ① Frame only: **E2L3600F**.
- ② Frame only: **E2LM3600F**.
- ③ For High Load Alarm option (B20): **E2LE360038B20W, LEM3600TB20**.

Please see TD01217001E for detailed dimensions.

300 A— 800 A

**E<sup>2</sup>M/E<sup>2</sup>MM/E<sup>2</sup>MW****E<sup>2</sup>M/E<sup>2</sup>MM/E<sup>2</sup>MW****Circuit Breakers with Interchangeable Non-Electronic Trip Units**

Maximum Continuous Ampere Rating at 40 °C	Magnetic Trip Range	Trip Unit Only Catalog Number	600 Vac Maximum 250 Vdc 35 kA at 480 Vac Three-Pole <sup>①</sup> Complete Breaker Catalog Number	1000Y/ 577 Vac Maximum 250 Vdc 18 kA at 1000 Vac Three-Pole <sup>②</sup> Complete Breaker Catalog Number	1200 Vac Maximum 12 kA at 1200 Vac Three-Pole <sup>③④</sup> Complete Breaker Catalog Number
<b>Thermal-Magnetic</b>					
400	1000–2000	—	—	—	<b>E2MW3400W</b>
500	1250–2500	—	—	—	<b>E2MW3500W</b>
600	1500–3000	<b>E2M3600TN</b>	<b>E2M3600W</b>	<b>E2MM3600W</b>	<b>E2MW3600W</b>
630	1600–3200	—	—	—	<b>E2MW3630W</b>
800	2000–4000	<b>E2M3800TX</b>	<b>E2M3800W</b>	<b>E2MM3800W</b>	<b>E2MW3800W</b>
<b>Magnetic Only</b>					
800	1500–3000	<b>E2M3800TMN</b>	<b>E2M3800MNW</b>	<b>E2MM3800MNW</b>	<b>E2MW3800MNW</b>
	1600–3200	—	—	—	<b>E2MW3800MVW</b>
	2000–4000	<b>E2M3800TMX</b>	<b>E2M3800MXW</b>	<b>E2MM3800MXW</b>	<b>E2MW3800MXW</b>
	2500–5000	<b>E2M3800TMP</b>	<b>E2M3800MPW</b>	<b>E2MM3800MPW</b>	—
	3000–6000	<b>E2M3800TMW</b>	<b>E2M3800MWW</b>	<b>E2MM3800MWW</b>	—

**Notes**

- ① Frame only: **E2M3800F**.  
 ② Frame only: **E2MM3800F**.  
 ③ 1200 V breakers are sold as “complete breakers” only.  
 ④ Maximum continuous ampere rating at 50 °C.

Please see TD01217001E for detailed dimensions.

# 2.6

## Molded Case Circuit Breakers

### Specialty Breakers

800 A

E<sup>2</sup>ME/E<sup>2</sup>MEM

2

E<sup>2</sup>MN



#### Circuit Breakers with Interchangeable Electronic Trip Units

Maximum Continuous Ampere Rating at 40 °C	Magnetic Trip Range	Trip Unit Only Catalog Number	600 Vac Maximum 250 Vdc 35 kA at 480 Vac Three-Pole ①	1000Y/ 577 Vac Maximum 250 Vdc 18 kA at 1000 Vac Three-Pole ②
			Complete Breaker Catalog Number	Complete Breaker Catalog Number
<b>310+ Electronic Instantaneous Only</b>				
800	500–2500	MEM3800TM	E2ME3800MW	E2MEM3800MW
	1000–4000	MEM3800TM2	E2ME3800M2W	E2MEM3800M2W
<b>310+ Electronic LSI ③</b>				
800	500–2500	MEM3800T	E2ME3800W	E2MEM3800W
	1000–4000	MEM3800T2	E2ME38002W	E2MEM38002W
<b>310+ Electronic ALSI with Maintenance Mode ③</b>				
800	500–2500	MEM380038T	E2ME380038W	E2MEM380038W
	1000–4000	MEM380038T2	E2ME3800382W	E2MEM3800382W

**Notes**

- ① Frame only: **E2M3800F**.
- ② Frame only: **E2MM3800F**.
- ③ For High Load Alarm option (B20): **E2ME380038B20W, MEM3800TB20**.

Please see TD01217001E for detailed dimensions.

400 A–1200 A

**E<sup>2</sup>N/E<sup>2</sup>NM****E<sup>2</sup>NM****Circuit Breakers with Interchangeable Electronic Trip Units**

Maximum Continuous Ampere Rating at 40 °C	Magnetic Trip Range	Trip Unit Only Catalog Number	600 Vac Maximum 250 Vdc 35 kA at 480 Vac Three-Pole	1000Y/ 577 Vac Maximum 250 Vdc 18 kA at 1000 Vac Three-Pole
			Complete Breaker Catalog Number	Complete Breaker Catalog Number
<b>310+ Electronic Instantaneous Only</b>				
800	500–2500	—	<b>E2N3800MW</b>	<b>E2NM3800MW</b>
1200	1250–5000	—	<b>E2N312MW</b>	<b>E2NM312MW</b>
<b>310+ Electronic LSI <sup>①</sup></b>				
400	500–2500	—	<b>E2N3400W</b>	<b>E2NM3400W</b>
500	500–2500	—	<b>E2N3500W</b>	<b>E2NM3500W</b>
600	500–2500	—	<b>E2N3600W</b>	<b>E2NM3600W</b>
700	500–2500	—	<b>E2N3700W</b>	<b>E2NM3700W</b>
800	500–2500	—	<b>E2N3800W</b>	<b>E2NM3800W</b>
900	1250–5000	—	<b>E2N3900W</b>	<b>E2NM3900W</b>
1000	1250–5000	—	<b>E2N310W</b>	<b>E2NM310W</b>
1200	1250–5000	—	<b>E2N312W</b>	<b>E2NM312W</b>
<b>310+ Electronic ALSI with Maintenance Mode <sup>①</sup></b>				
400	500–2500	—	<b>E2N340038W</b>	<b>E2NM340038W</b>
500	500–2500	—	<b>E2N350038W</b>	<b>E2NM350038W</b>
600	500–2500	—	<b>E2N360038W</b>	<b>E2NM360038W</b>
700	500–2500	—	<b>E2N370038W</b>	<b>E2NM370038W</b>
800	500–2500	—	<b>E2N380038W</b>	<b>E2NM380038W</b>
900	1250–5000	—	<b>E2N390038W</b>	<b>E2NM390038W</b>
1000	1250–5000	—	<b>E2N31038W</b>	<b>E2NM31038W</b>
1200	1250–5000	—	<b>E2N31238W</b>	<b>E2NM31238W</b>

**Notes**

<sup>①</sup> For High Load Alarm option (B20): **E2N380038B20W**.

Please see TD01217001E for detailed dimensions.

# 2.6

## Molded Case Circuit Breakers

### Specialty Breakers

1600 A–2000 A

E<sup>2</sup>R/E<sup>2</sup>RM

2

E<sup>2</sup>RM

#### Circuit Breakers with Electronic Trip Units



Maximum Continuous Ampere Rating at 40 °C	Magnetic Trip Range	Trip Unit Only Catalog Number	600 Vac Maximum 250 Vdc 35 kA at 480 Vac Three-Pole	1000Y/ 577 Vac Maximum 250 Vdc 18 kA at 1000 Vac Three-Pole
			Complete Breaker Catalog Number	Complete Breaker Catalog Number
<b>310+ Electronic LSI</b> <sup>①</sup>				
1600	2–8 x I <sub>n</sub>	—	<b>E2R316W</b>	<b>E2RM316W</b>
2000	2–8 x I <sub>n</sub>	—	<b>E2R320W</b>	<b>E2RM320W</b>
<b>310+ Electronic ALSI with Maintenance Mode</b> <sup>①</sup>				
1600	2–8 x I <sub>n</sub>	—	<b>E2R31638W</b>	<b>E2RM31638W</b>
2000	2–8 x I <sub>n</sub>	—	<b>E2R32038W</b>	<b>E2RM32038W</b>

**Notes**

<sup>①</sup> For High Load Alarm option (B20): **E2R1638B20W**.

Please see TD01217001E for detailed dimensions.

## Accessories

### Line and Load Terminals

Breaker Type	Maximum Breaker Amperes	Wire Type	AWG Wire Range (No. Conductors)	Catalog Number
E <sup>2</sup> F/E <sup>2</sup> FM	100	Cu/Al	#14–1/0 (1)	<b>3T100FB</b> (package of three)
	150	Cu	#4–4/0 (1)	<b>3T150FB</b> (package of three)
E <sup>2</sup> J/E <sup>2</sup> JM	250	Cu	#4–350 (1)	<b>T250KB</b>
E <sup>2</sup> K/E <sup>2</sup> KM/E <sup>2</sup> KW	225	Cu	#3–350 (1)	<b>T300K</b>
	350	Cu	250–500 (1)	<b>T350K</b>
	400	Cu	2/0–250 (2)	<b>3T400K</b> (three-pole kit)
E <sup>2</sup> LME/E <sup>2</sup> LMZ	400	Cu/Al	500–750 (1)	<b>3TA631LK</b>
E <sup>2</sup> L/E <sup>2</sup> LM/E <sup>2</sup> LW	400	Cu/Al	4/0–600 (1)	<b>3TA401LDK</b> (three-pole kit)
	600	Cu	250–350 (2)	<b>T602LD</b>
E <sup>2</sup> M/E <sup>2</sup> MM/E <sup>2</sup> MW	600	Cu	(2) 2/0–500 kcmil	<b>T600MA1</b>
	600	Cu/Al	(2) 1–500 kcmil	<b>TA700MA1</b>
	800 std.	Cu/Al	(3) 3/0–400 kcmil	<b>TA800MA2</b>
	800	Cu/Al	(2) 500–750 kcmil	<b>TA801MA</b>
	800	Cu	(3) 3/0–300 kcmil	<b>T800MA1</b>
E <sup>2</sup> N/E <sup>2</sup> NM	700	Cu	2/0–500 (2)	<b>T700NB1</b>
	1000	Cu	3/0–500 (3)	<b>T1000NB1</b>
	1200	Cu	3/0–400 (4)	<b>T1200NB3</b>
	1600	Cu/Al	500–1000 (4)	<b>TA1600RD</b>
	2000	Cu/Al	2–600 (6)	<b>TA2000RD</b>

### End Cap Terminals—For Use with Ring Type Terminals

Breaker Type	Maximum Breaker Amperes	Catalog Number	Metric Catalog Number	Imperial
E <sup>2</sup> F/E <sup>2</sup> FM	150	<b>KPEK1</b>	<b>KPEMK1</b>	—
E <sup>2</sup> J/E <sup>2</sup> JM	250	<b>KPEK2</b>	<b>KPEMK2</b>	—
E <sup>2</sup> K/E <sup>2</sup> KM/E <sup>2</sup> KW	400	<b>KPEK3</b>	<b>KPEMK3</b>	—
E <sup>2</sup> LME/E <sup>2</sup> LMZ	400	—	<b>L3RTWK</b>	—
E <sup>2</sup> L/E <sup>2</sup> LM/E <sup>2</sup> LW	600	<b>KPEK4</b>	<b>KPEMK4</b>	—

### External Accessories

#### Padlockable Handle Lock Hasp

Breaker Type	Catalog Number
E <sup>2</sup> F/E <sup>2</sup> FM	<b>PLK1</b>
E <sup>2</sup> J/E <sup>2</sup> JM	<b>PLK3</b>
E <sup>2</sup> K/E <sup>2</sup> KM/E <sup>2</sup> KW	<b>PLK3</b>
E <sup>2</sup> LME/E <sup>2</sup> LMZ	<b>LPHL</b>
E <sup>2</sup> L/E <sup>2</sup> LM/E <sup>2</sup> LW	<b>HLK4</b>
E <sup>2</sup> M/E <sup>2</sup> MM/E <sup>2</sup> MW	<b>HLK4</b>
E <sup>2</sup> N/E <sup>2</sup> NM	<b>PLK5</b>
E <sup>2</sup> R/E <sup>2</sup> RM	<b>HLK6</b>

## Internal Accessories

2

## Undervoltage Release ①

Breaker Type	UVR Type	Voltage Rating	Mounting Location	Catalog Number	Factory Modification Code
E <sup>2</sup> F/E <sup>2</sup> FM	Handle reset	208–240 Vac	Left pole	UVH1LP11K (thermal/magnetic only) ②	U18
	Handle reset	110–127 Vdc	Left pole	UVH1LP26K (thermal/magnetic only) ②	U42
E <sup>2</sup> J/E <sup>2</sup> JM	Handle reset	110–127 Vac	Left pole	UVH2LP08K ②	U18
	Handle reset	208–240 Vac	Left pole	UVH2LP11K ②	U22
	Handle reset	110–125 Vdc	Left pole	UVH2LP26K ②	T14
E <sup>2</sup> K/E <sup>2</sup> KM/E <sup>2</sup> KW	120 volt handle reset with LED	120 Vac	Left pole	UVM3LP08K ②③	U66
	120 volt handle reset with LED	120 Vac	Left pole	UVM3LP08KT ②④	U68
	Handle reset	110–127 Vac	Left pole	UVH3LP08K ②	U18
	Handle reset	208–240 Vac	Left pole	UVH3LP11K ②	U22
	Handle reset	110–125 Vdc	Left pole	UVH3LP26K ②	T14
E <sup>2</sup> LME/E <sup>2</sup> LMZ	Handle reset	110–127 Vac	Left pole	UVR120APK	U5
	Handle reset	110–125 Vdc	Left pole	UVR125DPK	U6
E <sup>2</sup> L/E <sup>2</sup> LM/E <sup>2</sup> LW/E <sup>2</sup> M/E <sup>2</sup> MM/ E <sup>2</sup> MW	120 volt handle reset with LED	120 Vac	Left pole	UVM4LP08K ②③	U66
	120 volt handle reset with LED	120 Vac	Left pole	UVM4LP08KT ②④	U68
	Handle reset	110–127 Vac	Left pole	UVH4LP08K ②	U18
	Handle reset	208–240 Vac	Left pole	UVH4LP11K ②	U22
	Handle reset	110–125 Vdc	Left pole	UVH4LP26K ②	T14
E <sup>2</sup> N/E <sup>2</sup> NM	120 volt handle reset with LED	120 Vac	Left pole	UVM5LP08K ③	U66
	120 volt handle reset with LED	120 Vac	Left pole	UVM5LT08K ④	U68
	Handle reset	110–127 Vac	Left pole	UVH5LP08K ②	U18
	Handle reset	208–240 Vac	Left pole	UVH5LP11K ②	U22
	Handle reset	110–125 Vdc	Left pole	UVH5LP26K ②	T14
E <sup>2</sup> R/E <sup>2</sup> RM	120 volt handle reset with LED	120 Vac	Right pole	UVM6RP08K ③⑤	U58
	Handle reset	110–127 Vac	Right pole	UVH6RP08K ⑤	U49
	Handle reset	208–240 Vac	Right pole	UVH6RP11K ⑤	U53
	Handle reset	110–125 Vdc	Right pole	UVH6RP26K ⑤	T33

## Notes

- ① Contact Eaton for internal accessory voltage ratings not listed.
- ② LH (RH also available).
- ③ Pigtail leads.
- ④ Terminal blocks.
- ⑤ RH only.

## Shunt Trip ①

Breaker Type	Voltage Rating	Mounting Location	Catalog Number	Factory Modification Code
E <sup>2</sup> F/E <sup>2</sup> FM	48–127 Vac or 48–60 Vdc	Left pole	<b>SNT1LP08K</b> ②	S06
	208–230 Vac or 110–127 Vdc	Left pole	<b>SNT1LP12K</b> ②	S10
E <sup>2</sup> J/E <sup>2</sup> JM	110–240 Vac or 110–125 Vdc	Left pole	<b>SNT2P11K</b> ③	S10
E <sup>2</sup> K/E <sup>2</sup> KM/E <sup>2</sup> KW	110–240 Vac or 110–125 Vdc	Left pole	<b>SNT3P11K</b> ③	S10
E2LME/E2LMZ	24 Vac/Vdc	Left pole	<b>SNT024CPK</b>	S6
	48–60 Vac/Vdc	Left pole	<b>SNT4860CPK</b>	S7
	110–240 Vac/Vdc	Left pole	<b>SNT120CPK</b>	S2
E <sup>2</sup> L/E <sup>2</sup> LM/E <sup>2</sup> LW/E <sup>2</sup> M/ E <sup>2</sup> MM/E <sup>2</sup> MW	48–60 Vac	Left pole	<b>SNT4LP05K</b> ②	S06
	48–60 Vdc	Left pole	<b>SNT4LP23K</b> ②	S86
	110–240 Vac	Left pole	<b>SNT4LP11K</b> ②	S10
	110–125 Vdc	Left pole	<b>SNT4LP26K</b> ②	S42
E <sup>2</sup> N/E <sup>2</sup> NM	110–240 Vac	Left pole	<b>SNT5LP11K</b> ②	S10
	110–125 Vdc	Left pole	<b>SNT5LP26K</b> ②	S42
E <sup>2</sup> R/E <sup>2</sup> RM	110–240 Vac	Right pole	<b>SNT6P11K</b> ④	S29
	110–125 Vdc	Right pole	<b>SNT6P26K</b> ④	S45

## Auxiliary Switch

Breaker Type	Number of Sets of Contacts (1A and 1B)	Mounting Location	Catalog Number	Factory Modification Code
E <sup>2</sup> F/E <sup>2</sup> FM	1	Right	<b>A1X1PK</b>	A06
	2	Right	<b>A2X1RPK</b>	A13
E <sup>2</sup> J/E <sup>2</sup> JM	1	Right	<b>A1X2PK</b>	A06
	2	Right	<b>A2X2PK</b>	A13
E <sup>2</sup> K/E <sup>2</sup> KM/E <sup>2</sup> KW	1	Right	<b>A1X3PK</b>	A06
	2	Right	<b>A2X3PK</b>	A13
E <sup>2</sup> LME/E <sup>2</sup> LMZ	1	Right	<b>AUX1A1BPK</b>	A1
	2	Right	<b>AUX2A2BPK</b>	A2
E <sup>2</sup> L/E <sup>2</sup> LM/E <sup>2</sup> LW/E <sup>2</sup> M/ E <sup>2</sup> MM/E <sup>2</sup> MW	1	Right	<b>A1X4PK</b>	A06
	2	Right	<b>A2X4PK</b>	A13
E <sup>2</sup> N/E <sup>2</sup> NM	1	Right	<b>A1X5PK</b>	A06
	2	Right	<b>A2X5PK</b>	A13
E <sup>2</sup> R/E <sup>2</sup> RM	2	Right	<b>A2X6RPK</b>	A12
	4	Right	<b>A4X6RPK</b>	A19

## Alarm (Signal/Lockout Switch)

Breaker Type	Number of Sets of Contacts (Make and Break)	Mounting Location	Catalog Number	Factory Modification Code
E <sup>2</sup> F/E <sup>2</sup> FM	1	Right	<b>A1L1LPK/A1L1RPK</b>	B06
	2	Right	<b>A2L1LPK/A2L1RPK</b>	B13
E <sup>2</sup> J/E <sup>2</sup> JM	1	Right	<b>A1L2LPK/A1L2RPK</b>	B06
E <sup>2</sup> K/E <sup>2</sup> KM/E <sup>2</sup> KW	1	Right	<b>A1L3LPK/A1L3RPK</b>	B06
	2	Right	<b>A2L3LPK/A2L3RPK</b>	B13
E <sup>2</sup> LME/E <sup>2</sup> LMZ	1	Right	<b>ALM1M1BJPK</b>	B1
	2	Right	<b>ALM2M2BJPK</b>	B3
E <sup>2</sup> L/E <sup>2</sup> LM/E <sup>2</sup> LW/E <sup>2</sup> M/ E <sup>2</sup> MM/E <sup>2</sup> MW	1	Right	<b>A1L4LPK/A1L4RPK</b>	B06
	2	Right	<b>A2L4LPK/A2L4RPK</b>	B13
E <sup>2</sup> N/E <sup>2</sup> NM	1	Right	<b>A1L5LPK/A1L5RPK</b>	B06
	2	Right	<b>A2L5LPK/A2L5RPK</b>	B13
E <sup>2</sup> R/E <sup>2</sup> RM	1	Right	<b>A1L6RPK</b>	B05
	2	Right	<b>A2L6RPK</b>	B12

## Notes

- ① Contact Eaton for internal accessory voltage ratings not listed.
- ② LH (RH also available).
- ③ LH or RH.
- ④ RH only.

# 2.6

## Molded Case Circuit Breakers

### Specialty Breakers

#### Dimensions

Approximate Dimensions in Inches (mm)

2

Please see TD01217001E for detailed dimensions.

#### 3 A–150 A

##### E<sup>2</sup>F/E<sup>2</sup>FM

Sealed Breakers with Non-Interchangeable Trip Unit—  
Include Line/Load Terminals Non-Electronic Trip Units

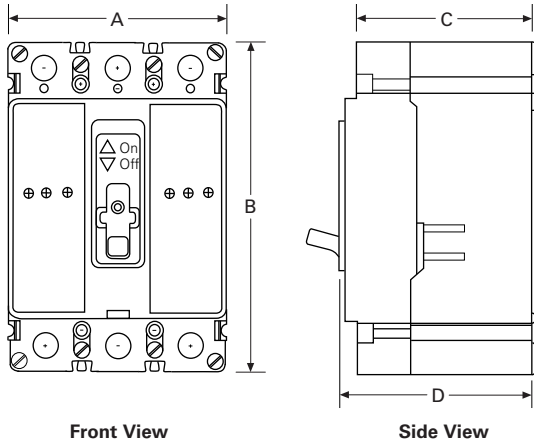

Description	Dimensions in Inches (mm)
A	4.13 (104.9)
B	6.00 (152.4)
C	3.38 (85.9)
D	3.50 (88.9)

#### 70 A–250 A

##### E<sup>2</sup>J/E<sup>2</sup>JM

Circuit Breakers with Interchangeable Non-Electronic  
Trip Units

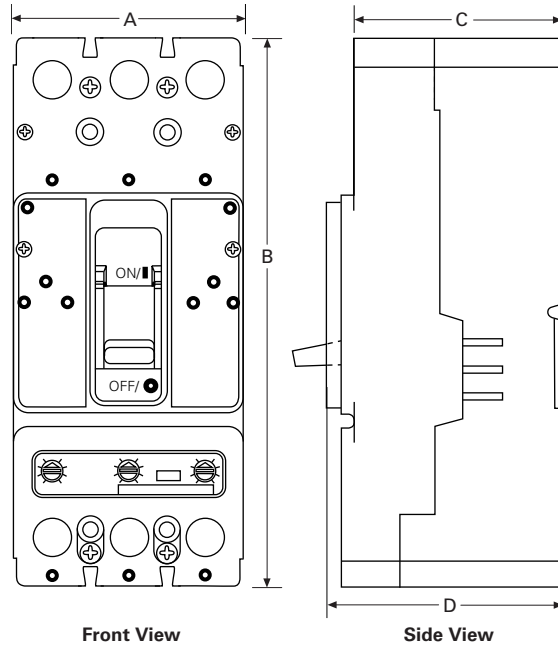

Description	Dimensions in Inches (mm)
A	4.13 (104.9)
B	10.00 (254.0)
C	4.06 (103.1)
D	4.31 (109.5)

Approximate Dimensions in Inches (mm)

Please see TD01217001E for detailed dimensions.

**100 A–400 A**

**E<sup>2</sup>K/E<sup>2</sup>KM/E<sup>2</sup>KW**

**Circuit Breakers with Interchangeable Non-Electronic Trip Units**

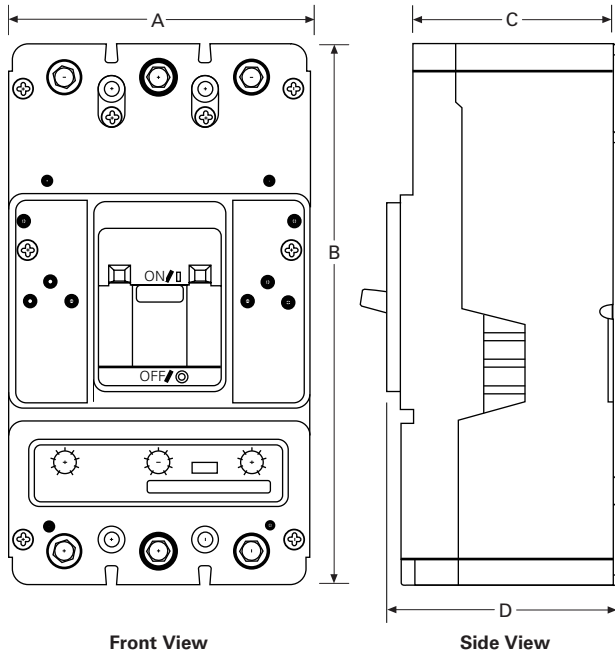

**100 A–400 A**

**E<sup>2</sup>KE/E<sup>2</sup>KEM**

**Circuit Breakers with Interchangeable Electronic Trip Units**

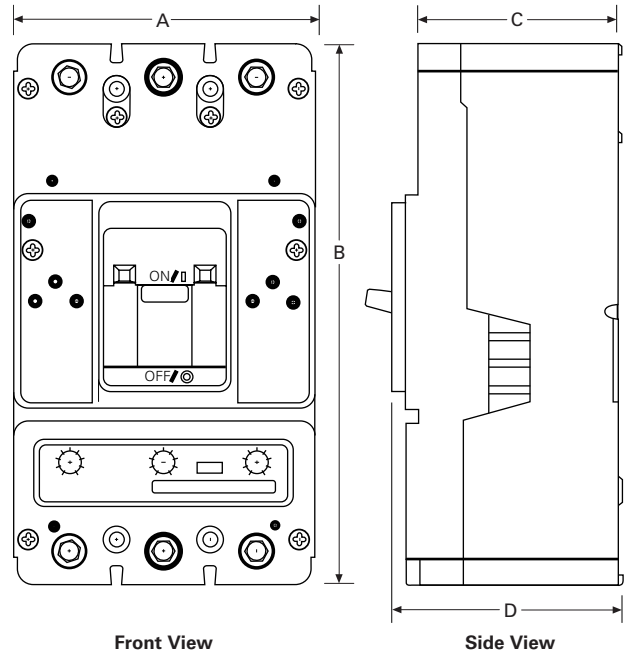

Description	Dimensions in Inches (mm)
A	5.49 (139.4)
B	10.13 (257.3)
C	4.06 (103.1)
D	4.31 (109.5)

Description	Dimensions in Inches (mm)
A	5.49 (139.4)
B	10.13 (257.3)
C	4.06 (103.1)
D	4.31 (109.5)

# 2.6

## Molded Case Circuit Breakers

### Specialty Breakers

Approximate Dimensions in Inches (mm)

Please see TD01217001E for detailed dimensions.

2

#### 160 A–400 A

##### E<sup>2</sup>LME/E<sup>2</sup>LMZ Circuit Breakers

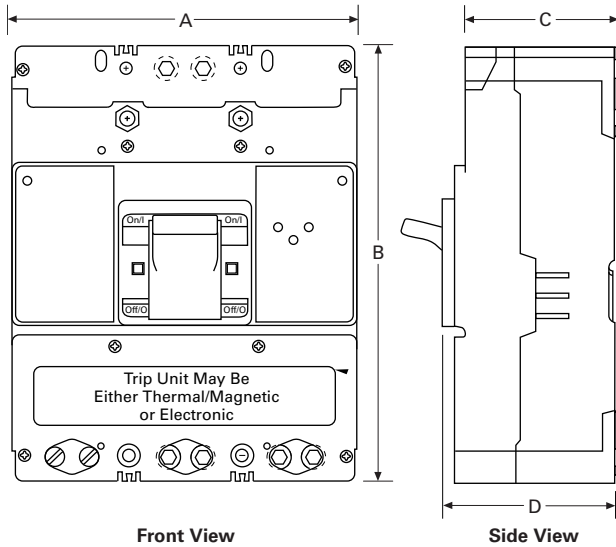

#### 300 A–600 A

##### E<sup>2</sup>L/E<sup>2</sup>LM/E<sup>2</sup>LW Circuit Breakers with Interchangeable Electronic Trip Units

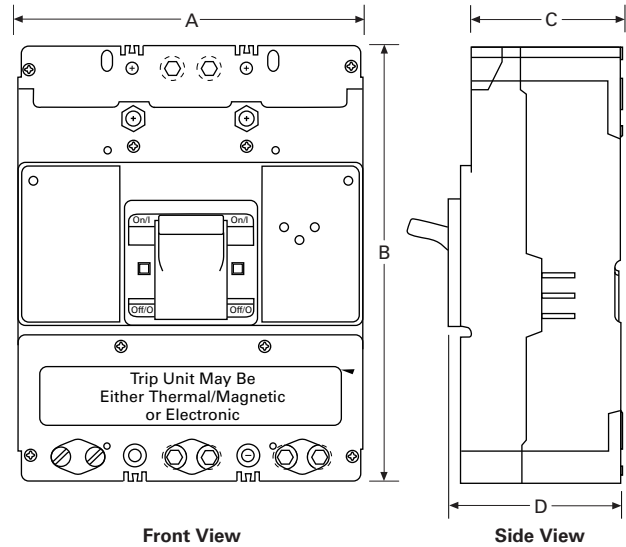

Description	Dimensions in Inches (mm)
A	5.48 (139.2)
B	10.13 (257.3)
C	4.00 (101.6)
D	4.22 (107.1)

Description	Dimensions in Inches (mm)
A	8.25 (209.6)
B	10.75 (273.1)
C	4.06 (103.1)
D	4.38 (111.3)

Approximate Dimensions in Inches (mm)

Please see TD01217001E for detailed dimensions.

**300 A–600 A**

**E<sup>2</sup>LE/E<sup>2</sup>LEM**

**Circuit Breakers with Interchangeable Electronic Trip Units**

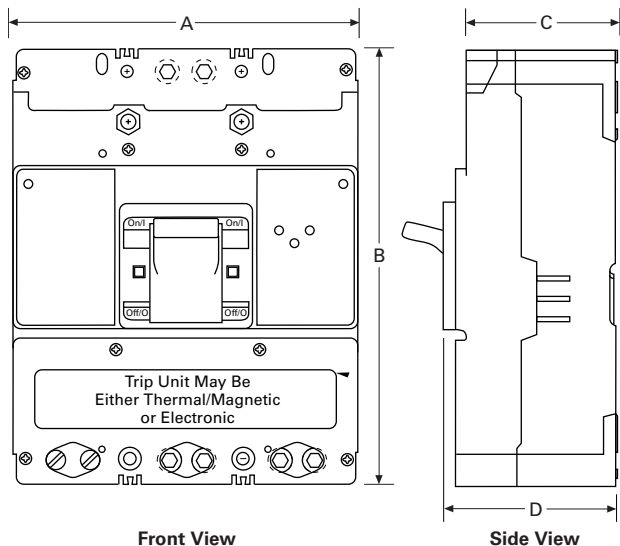

Description	Dimensions in Inches (mm)
A	8.25 (209.6)
B	10.75 (273.1)
C	4.06 (103.1)
D	4.38 (111.3)

**300 A–800 A**

**E<sup>2</sup>M/E<sup>2</sup>MM/E<sup>2</sup>MW**

**Circuit Breakers with Interchangeable Non-Electronic Trip Units**

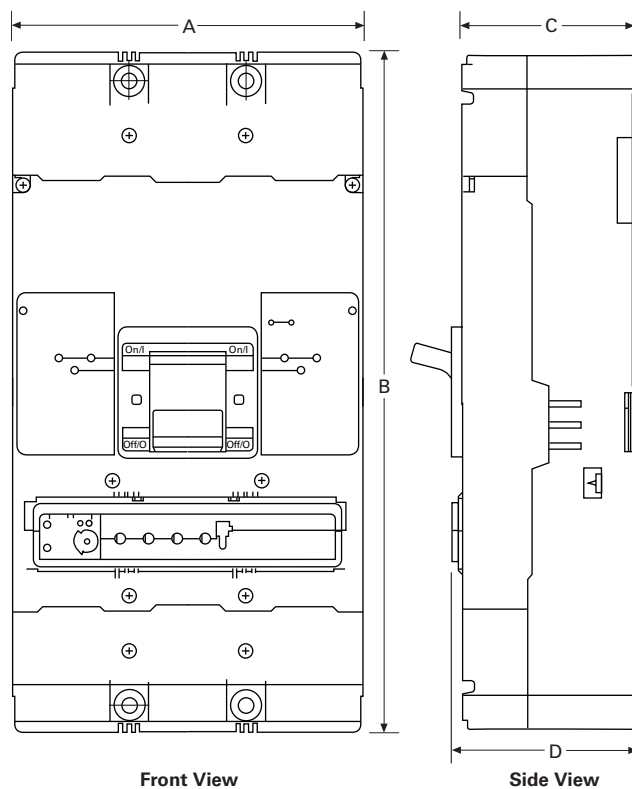

Description	Dimensions in Inches (mm)
A	8.25 (209.6)
B	16.00 (406.4)
C	4.06 (103.1)
D	4.38 (111.3)

# 2.6

## Molded Case Circuit Breakers

### Specialty Breakers

Approximate Dimensions in Inches (mm)

Please see TD01217001E for detailed dimensions.

2

#### 800 A

##### E<sup>2</sup>ME/E<sup>2</sup>MEM

##### Circuit Breakers with Interchangeable Electronic Trip Units

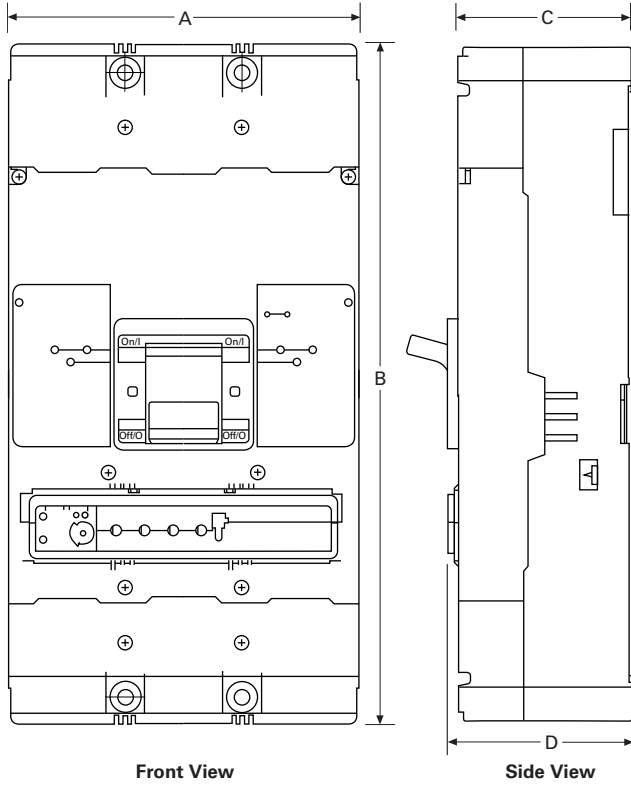

Description	Dimensions in Inches (mm)
A	8.25 (209.6)
B	16.00 (406.4)
C	4.06 (103.1)
D	4.38 (111.3)

#### 400 A–1200 A

##### E<sup>2</sup>N/E<sup>2</sup>NM

##### Circuit Breakers with Interchangeable Electronic Trip Units

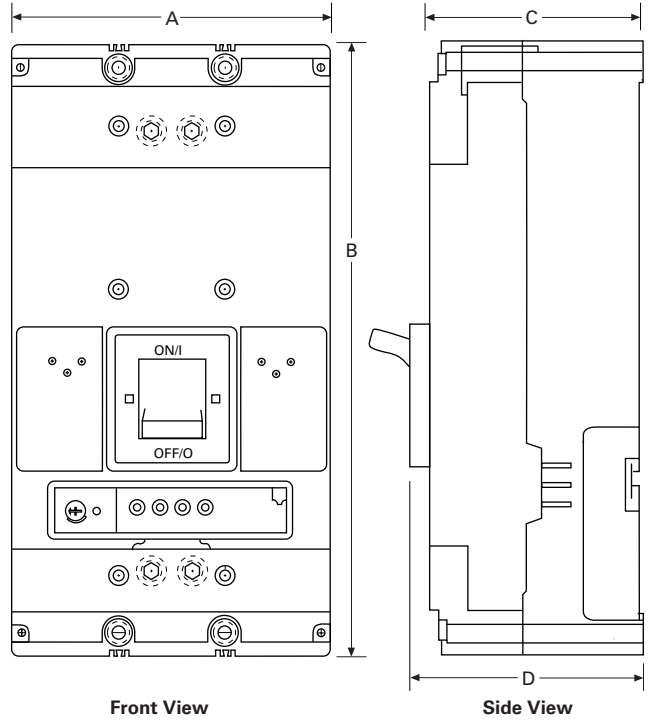

Description	Dimensions in Inches (mm)
A	8.25 (209.6)
B	16.00 (406.4)
C	5.50 (139.7)
D	6.00 (152.4)

Approximate Dimensions in Inches (mm)

Please see TD01217001E for detailed dimensions.

**1600 A–2000 A**

**E<sup>2</sup>R/ E<sup>2</sup>RM**  
**Circuit Breakers with Electronic Trip Units**

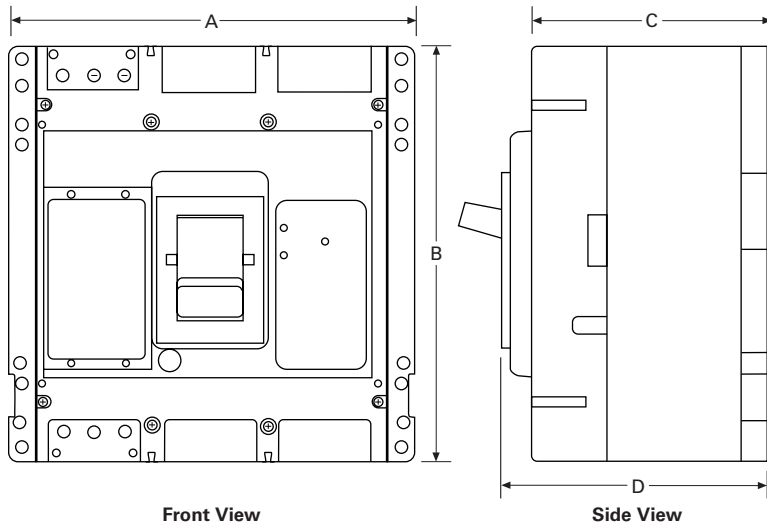

Description	Dimensions in Inches (mm)
A	15.50 (393.7)
B	16.00 (406.4)
C	9.00 (228.6)
D	10.00 (254.0)

## E2VAC Mining Vacuum Circuit Breaker

2



## E2VAC Mining Vacuum Circuit Breaker

## Product Overview

The Eaton E2VAC mining vacuum circuit breaker is a vacuum-based solution with advanced communications, designed to improve safety, reliability and productivity.

Available in 480, 600 and 1000 Vac styles, the E2VAC provides protection for up to 500 A in motor circuits and trailing cables. By using vacuum contactors to make and break line/load connections, the dangers of an external arc flash are eliminated while reliably switching normal load and high stress fault currents.

The E2VAC can be installed as a fixed breaker, but it is also available with remote racking capability that allows personnel to remove the breaker from service:

- While standing at a safe distance from the breaker
- Completely disconnecting the breaker from live voltage without having to depower the entire power center for maintenance

Eaton's EDR-5000 distribution relay is fully integrated into the E2VAC breaker and provides advanced monitoring capability for real power, reactive power, power factor and frequency in addition to the standard voltage, current and phase angle measurements.

## Application Description

Combining robust circuit protection and safety features with state-of-the-art monitoring capability, the E2VAC breaker is ideal for underground power center applications.

## Features and Benefits

- Industry-leading vacuum interrupter (VI) technology used to eliminate the risk of external arc flash; includes VI malfunction detection
- Blown fuse detection with audible and visible indication
- Phase loss and open CT detection
- Dust-tight receptacle supplies power from the front of the breaker
- EDR-5000 distribution relay provides voltage, current and phase angle monitoring capability
- Instantaneous protection for short circuit and ground faults; phase imbalance and undervoltage protection
- Advanced user interface with LEDs and LCD screen for fault indication and keypad for programming
- Vacuum sealed contacts improve the equipment life, especially in harsh environments

## Contents

## Description

## Page

Engine Generator Circuit Breakers . . . . .	V4-T2-341
Direct Current Circuit Breakers . . . . .	V4-T2-347
PVGard Solar Circuit Breakers—600 Vdc Per-Pole and 1000 Vdc Poles-in-Series . . . . .	V4-T2-361
E <sup>2</sup> Mining Service Breakers . . . . .	V4-T2-374
E2VAC Mining Vacuum Circuit Breaker	
Catalog Number Selection . . . . .	V4-T2-401
Product Selection . . . . .	V4-T2-401
Dimensions . . . . .	V4-T2-402
Classic Mining Breakers	
Add-On Ground Fault Protection—Type GFR . . . . .	V4-T2-417

## Key Differentiators

- Remote racking capability greatly increases service accessibility and safety by keeping the operator at a great distance from the arc flash
- Maintenance Mode enables lower instantaneous pickups to minimize the risk of arc flash energy release during breaker service
- Advanced monitoring capability for kW, kVAR, power factor and frequency
- Reports sequence of up to 300 events and stores fault data for up to 20 faults
- Reduced footprint allows users to maximize space in the power center

Catalog Number Selection

E2VAC Mining Vacuum Circuit Breaker

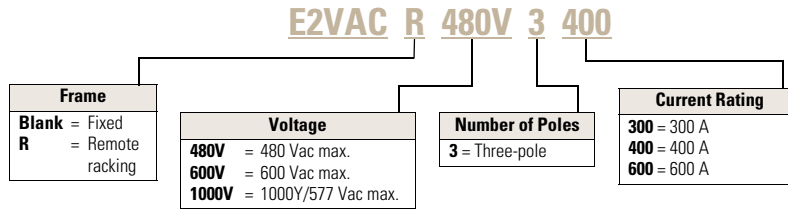

Product Selection

E2VAC



E2VAC Mining Circuit Breakers with EDR-5000 Relay

Maximum Continuous Ampere Rating at 40 °C	Trip Range	480 Vac Maximum 100 kA, Three-Pole Catalog Number	600 Vac Maximum 100 kA, Three-Pole Catalog Number	1000 Vac Maximum 100k A, Three-Pole Catalog Number
<b>Fixed Standard Breaker</b>				
300	50–320	E2VAC480V3300	E2VAC600V3300	E2VAC1000V3300
400	265–405	E2VAC480V3400	E2VAC600V3400	E2VAC1000V3400
600	408–600	E2VAC480V3600	E2VAC600V3600	E2VAC1000V3600
<b>Standard Breaker with Remote Racking</b>				
300	50–320	E2VACR480V3300	E2VACR600V3300	E2VACR1000V3300
400	265–405	E2VACR480V3400	E2VACR600V3400	E2VACR1000V3400
600	408–600	E2VACR480V3600	E2VACR600V3600	E2VACR1000V3600

# 2.6

## Molded Case Circuit Breakers

### Specialty Breakers

#### Dimensions

Approximate Dimensions in Inches (mm)

2

#### Fixed Standard E2VAC Breaker

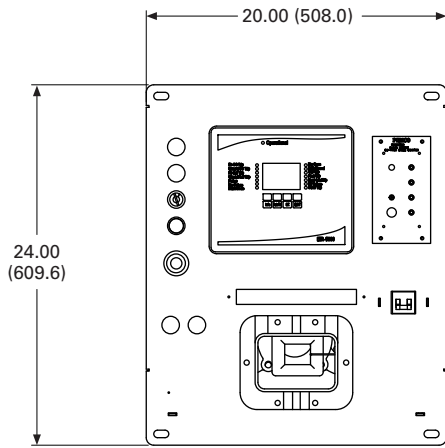

Front View

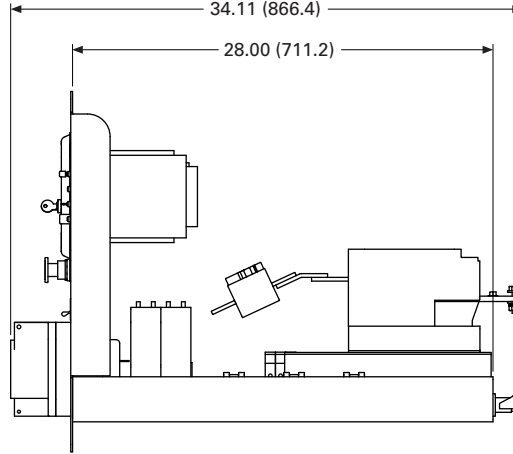

Side View

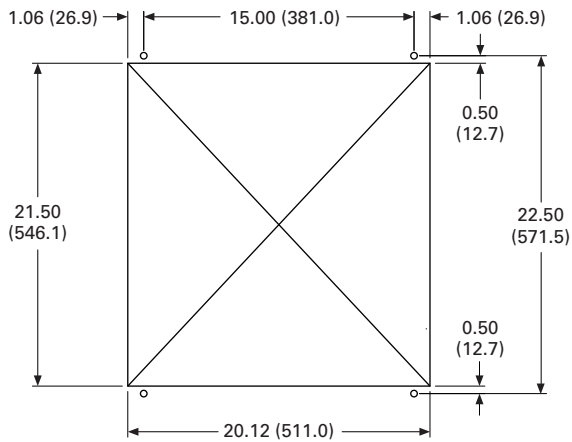

Recommended Cutout

**Contents**

<i>Description</i>	<i>Page</i>
Engine Generator Circuit Breakers . . . . .	<b>V4-T2-341</b>
Direct Current Circuit Breakers. . . . .	<b>V4-T2-347</b>
PVGard Solar Circuit Breakers—600 Vdc Per-Pole and 1000 Vdc Poles-in-Series. . . . .	<b>V4-T2-361</b>
E <sup>2</sup> Mining Service Breakers . . . . .	<b>V4-T2-374</b>
E2VAC Mining Vacuum Circuit Breaker . . . . .	<b>V4-T2-400</b>
Classic Mining Breakers	
Product Selection . . . . .	<b>V4-T2-405</b>
Accessories . . . . .	<b>V4-T2-410</b>
Reference Information. . . . .	<b>V4-T2-412</b>
Add-On Ground Fault Protection—Type GFR . . . . .	<b>V4-T2-417</b>

**Classic Mining Breakers****Product Overview**

Classic mining service circuit breakers continue to be manufactured and are primarily applied to achieve an exact physical and electronic replacement of previously Cutler-Hammer

installed Westinghouse equipment. To upgrade to the current offering of E<sup>2</sup> mining circuit breakers, consult the cross reference information on **Page V4-T2-412**.

**AC Interrupting Capacity, Symmetrical Amperes**

60 Hz AC Volts	Breaker Type				All Other 1000 Volt Breakers <sup>②</sup>
	KAM	LAM, MAM, NBM	HKAM	HLAM <sup>②</sup>	
240	25,000	42,000	—	—	—
480	22,000	30,000	—	—	—
600	22,000	22,000	—	—	—
1000 <sup>①</sup>	—	—	10,000	12,000	14,000

**Special DC Interrupting Capacity**

Breaker Type	Maximum Ampere Rating	Interrupting Capacity (Amperes) at 300–330 Vdc Single-Pole		Two Poles in Series <sup>④</sup>	
		0.0–0.15 mH Inductance <sup>③</sup>	0.15–0.5 mH Inductance	0.5–0.9 mH Inductance	2.4 mH Inductance
KAM	225	15,000	10,000	15,000	5000
LAM	400/600	15,000	10,000	15,000	5000
MAM	800	15,000	10,000	15,000	5000
NBM	1200	15,000	10,000	15,000	5000

**Notes**

- <sup>①</sup> Based on circuit power factor of 50% or greater.  
<sup>②</sup> HLAM must be rear stud connected. If front connected, interrupting capacity rating is 10,000 amperes.  
<sup>③</sup> Resistive circuit.  
<sup>④</sup> Two poles in electrical series in ungrounded leg of circuit.

**Classic Circuit Breakers For Mining Service**

2

**Undervoltage Release Data**

Undervoltage releases are calibrated to pick up at 72 to 85% of rated voltage dropout between 35 to 70% of rated voltage.

Breaker Type	Volts	Line Amperes	Series Resistors <sup>①</sup>	Total VA
KAM, HKAM <sup>①</sup>	480/60	0.021	10,000	10.1
	240/60	0.019	—	4.6
	120/60	0.021	—	2.5
	120/60 <sup>②</sup>	0.13	—	15.6
LAM, HLAM, MAM, HMAM, NBM, HNB M <sup>①</sup>	480/60	0.033	12,000 <sup>③</sup>	15.9
	240/60	0.028	6,000	6.7
	120/60	0.029	—	3.5
	120/60 <sup>②</sup>	0.13	—	15.6

**Shunt Trip Coil Data**

Breaker Type	Volts	Amperes	VA
KAM, HKAM, LAM, HLAM, MAM, HMAM, NBM, HNB M	480/60	0.085	40.8
	240/60	1.7	408
	120/60	0.88	105.6
	48 DC	8.0	384

**Notes**

- ① Supplied for external customer mounting.
- ② New design electrical reset UVR.
- ③ 16,000 for Type MAM and HMAM.

**Product Selection**

For reference only. Replace these frames with E2 Series. See Cross-Reference information beginning on **Page V4-T2-412**.

**Classic Mining Service Circuit Breakers**

Breaker Type	Frame Style Numbers <sup>①②</sup>	Poles	Amperes	Trip Type	Accessories (Included in Frame)	Magnetic Trip Range, Amperes <sup>③</sup>
KAM	2609D60G64	2	180	M	None	200–400
	1291C26G07	2	180	M	UVR <sup>④</sup>	200–400
	2609D60G66	2	180	M	Standard shunt trip <sup>③</sup>	200–400
	1291C26G01	2	225	TM	UVR <sup>④</sup>	300–700
	1291C26G02	2	225	TM	UVR <sup>④</sup>	500–1000
	2609D60G67	3	180	M	None	200–400
	1291C26G08	3	180	M	UVR <sup>④</sup>	200–400
	2609D60G69	3	180	M	Standard shunt trip <sup>③</sup>	200–400
	5685D48G75	3	225	TM	None	300–700
	5685D48G74	3	225	TM	None	500–1000
	1291C26G03	3	225	TM	UVR <sup>④</sup>	300–700
	1291C26G04	3	225	TM	UVR <sup>④</sup>	500–1000
	2609D60G01	3	225	TM	Standard shunt trip <sup>③</sup>	300–700
	2609D60G02	3	225	TM	Standard shunt trip <sup>③</sup>	500–1000
	2609D60G40	3	225	M	None	300–700
	2609D60G41	3	225	M	None	500–700
	1291C26G05	3	225	M	UVR <sup>④</sup>	300–700
1291C26G06	3	225	M	UVR <sup>④</sup>	500–1000	
LAM	1291C32G01	2	400	TM	UVR <sup>④</sup>	500–1000
	2609D60G61	2	400	M	Shunt trip (48 Vdc)	750–1500
	1291C32G03	3	400	TM	UVR <sup>④</sup>	500–1000
	5685D48G73	3	400	TM	None	800–1600
	1291C32G02	3	400	TM	UVR <sup>④</sup>	800–1600
	2609D60G03	3	400	TM	Standard shunt trip <sup>③</sup>	800–1600
	2609D60G44	3	400	M	None	800–1600
	1291C32G04	3	400	M	UVR <sup>④</sup>	800–1600

**Notes**

- ① Terminals not included in style number.
- ② All breakers listed are complete with accessories indicated.
- ③ Rated 120 volts/60 Hz: undervoltage release is handle reset type.
- ④ UVR is auto-reset type, 120 Vac.

M = magnetic only; TM = thermal-magnetic.

# 2.6

## Molded Case Circuit Breakers

### Specialty Breakers

For reference only. Replace these frames with E2 Series. See Cross-Reference information beginning on **Page V4-T2-412**.

2





#### Classic Mining Service Circuit Breakers, continued

Breaker Type	Frame Style Numbers <sup>①②</sup>	Poles	Amperes	Trip Type	Accessories (Included in Frame)	Magnetic Trip Range, Amperes <sup>③</sup>
MAM	2609D60G17	2	600	TM	UVR <sup>④</sup>	750–1500
	2609D60G18	2	800	TM	UVR <sup>④</sup>	1000–2000
	2609D60G63	3	400	TM	UVR <sup>④</sup>	2000–4000
	5685D48G72	3	600	TM	None	1500–3000
	2609D60G19	3	600	TM	UVR <sup>④</sup>	1500–3000
	2609D60G04	3	600	TM	Standard shunt trip <sup>③</sup>	1500–3000
	2609D60G05	3	800	TM	Standard shunt trip <sup>③</sup>	2000–4000
	5685D48G71	3	800	TM	None	2000–4000
	2609D60G20	3	800	TM	UVR <sup>④</sup>	2000–4000
	2609D60G46	3	800	M	None	1500–3000
	2609D60G47	3	800	M	UVR <sup>④</sup>	1500–3000
	2609D60G48	3	800	M	None	2000–4000
	2609D60G49	3	800	M	UVR <sup>④</sup>	2000–4000
NBM	1229C37G13	2	1000	TM	UVR <sup>④</sup>	1500–3000
	1229C37G14	2	1200	TM	UVR <sup>④</sup>	2000–4000
	1227C36G10	3	1000	TM	None	2500–5000
	1229C37G15	3	1000	TM	UVR <sup>④</sup>	2500–5000
	1227C36G13	3	1000	TM	Standard shunt trip <sup>③</sup>	2500–5000
	1227C36G14	3	1200	TM	Standard shunt trip <sup>③</sup>	2500–5000
	1227C36G09	3	1200	TM	None	2500–5000
	1229C37G16	3	1200	TM	UVR <sup>④</sup>	2500–5000
	1227C36G19	3	1200	M	None	2500–5000
	1229C37G17	3	1200	M	UVR <sup>④</sup>	2500–5000

#### Notes

- ① Terminals not included in style number.
  - ② All breakers listed are complete with accessories indicated.
  - ③ Rated 120 volts/60 Hz: undervoltage release is handle reset type.
  - ④ UVR is auto-reset type, 120 Vac.
- M = magnetic only; TM = thermal-magnetic.

## 1000 Volt Classic Mining Service Circuit Breakers

Breaker Type	Frame Style Numbers	Poles	Amperes	Trip Type	Accessories (Included in Frame)	Magnetic Trip Range, Amperes <sup>①</sup>	
<b>HKAM</b> 	HKAM	<b>2609D60G70</b>	3	180	M	None	200–400
		<b>1291C26G16</b>	3	180	M	UVR <sup>②</sup>	200–400
		<b>5685D48G87</b>	3	225	TM	None	300–700
		<b>1291C26G12</b>	3	225	TM	UVR <sup>②</sup>	300–700
		<b>5685D48G86</b>	3	225	TM	None	500–1000
		<b>1291C26G13</b>	3	225	TM	UVR <sup>②</sup>	500–1000
		<b>1291C26G14</b>	3	225	M	UVR <sup>②</sup>	300–700
		<b>1291C26G15</b>	3	225	M	UVR <sup>②</sup>	500–1000
<b>HLAM</b> 	HLAM	<b>5685D48G85</b>	3	400	TM	None	800–1600
		<b>1291C32G07</b>	3	400	TM	UVR <sup>②</sup>	800–1600
		<b>1291C32G09</b>	3	400	M	UVR <sup>②</sup>	800–1600
<b>HMAM</b> 	HMAM	<b>5685D48G84</b>	3	600	TM	None	1500–3000
		<b>2609D60G28</b>	3	600	TM	UVR <sup>③</sup>	1500–3000
		<b>5685D48G83</b>	3	800	TM	None	2000–4000
		<b>2609D60G29</b>	3	800	TM	UVR <sup>③</sup>	2000–4000
		<b>2609D60G57</b>	3	800	M	UVR <sup>③</sup>	1500–3000
		<b>2609D60G58</b>	3	800	M	UVR <sup>③</sup>	2000–4000
<b>HNAM</b> 	HNBM	<b>1227C36G12</b>	3	1000	TM	None	2500–5000
		<b>1229C37G19</b>	3	1000	TM	UVR <sup>②</sup>	2500–5000
		<b>1227C36G11</b>	3	1200	TM	None	2500–5000
		<b>1229C37G20</b>	3	1200	TM	UVR <sup>②</sup>	2500–5000
		<b>1229C37G18</b>	3	1200	M	UVR <sup>②</sup>	2500–5000

**Notes**

① The magnetic trip range does not change when rating plug is changed.

② 120 volt, 60 Hz electrical reset type.

③ Rated 120 volts, 60 Hz; undervoltage release is handle reset type.

M = magnetic only; TM = thermal-magnetic.

## Classic Mining Service Breaker Frames Only

Breaker Type	Frame Size, Amperes	Number of Poles	Style Numbers
KAM ①	225	2	2602D86G11
	225	3	2602D86G12
KAMH ①	225	2	2602D86G13
	225	3	2602D86G14
HKAM ①	225	3	1264C99G05
LAM ②	400	2	2602D99G05
	400	3	2602D99G06
LAMH ②	400	2	2602D99G07
	400	3	2602D99G08
HLAM ②	400	3	1264C99G02
LAM3600F	600	3	2603D48G07
LAMH3600F	600	3	2603D48G08
HLAM3600F	600	3	2603D48G09

Breaker Type	Frame Size, Amperes	Number of Poles	Style Numbers
MAM ②	800	2	2600D43G11
	800	3	2600D43G12
MAMH ②	800	2	2600D43G13
	800	3	2600D43G14
HMAM ②	800	3	1264C99G03
NBM ②	1200	2	2610D64G07
	1200	3	2610D64G08
NBMH ②	1200	2	2610D64G09
	1200	3	2610D64G10
HNBM ②	1200	3	2610D64G13

## Trip Units for Classic Mining Circuit Breakers

Breaker Type	Conductor Size	Magnetic Trip Range, Amperes	Maximum Continuous Amperes	Thermal-Magnetic Three-Pole ③ Style Numbers	Magnetic Only Three-Pole Style Numbers
HKAM	#6	150–400	180	—	2609D99G22
	#4–#3	300–700	225	5685D48G40	2611D75G01
	#4–#1	500–1000	225	5685D48G34	2611D75G02
HLAM	#4–#1	750–1500	400	5685D48G97	2609D99G21
	#2–#2/0	800–1600	400	5685D48G28	2611D75G03
HLAM600	#2–2/0	750–1500	600	2609D99G20	—
	2/0–500 kcmil	1500–3000	600	2609D99G19	—
HMAM	#2–#2/0	750–1500	600	—	—
	2/0–500 kcmil	1500–3000	600	5685D48G22	2611D75G04 ④
	#1–3/0	1000–2000	800	—	—
HNBM	3/0–500 kcmil	2000–4000	800	5685D48G16	2611D75G05
	2/0–500 kcmil	1500–3000	1000	—	—
	4/0–500 kcmil	2500–5000	1000	5685D48G10	—
HNBM	3/0–500 kcmil	2000–4000	1200	—	—
	4/0–500 kcmil	2500–5000	1200	5685D48G04	2611D75G07

**Notes**

- ① Frame modified for left-hand mounting of UVR attachment.  
 ② Frame modified for right-hand mounting of UVR attachment.  
 ③ Three-pole trip units only are suitable for replacement in 1000 volt mining service circuit breakers.  
 ④ 800 amperes.

**Terminals For Classic Mining Service Breakers**

Terminals are UL listed for wire type and range listed below.  
When used with aluminum conductors, use joint compound.

Breaker Type	Terminal Type	Maximum Amperes	Package of 3 Line Terminals Style Number	Wire Range, Type
FBM, HFBM	Style pressure type terminals	100	<b>624B100G02</b>	#14–1/0 Al/Cu
	Optional Al/Cu pressure terminals	50	<b>624B100G10</b>	#14–#4 Al/Cu
		100	<b>624B100G17</b>	#4–4/0 Al/Cu

**Terminals For Mining Service Breakers**

Breaker Type	Terminal Type	Maximum Amperes	Terminal Catalog Number	Wire Range, Type Number of Cables
KAM, HKAM	Standard pressure terminals (copper only)	225	<b>T225LA</b>	(1) #6–350 kcmil
	Optional Al/Cu pressure terminals	225	<b>TA225LA1</b>	(1) #6–350 kcmil Cu, or (1) #4–350 kcmil Al
LAM	Standard copper pressure terminals	225	<b>T225LA</b>	(1) #6–350 kcmil Cu
		400	<b>T401LA</b>	(1) #4–250 kcmil Cu plus (1) 3/0–600 kcmil Cu
	Optional Al/Cu pressure terminals	225	<b>TA225LA1</b>	(1) #6–350 kcmil Cu, or (1) #4–350 kcmil Al
		400	<b>TA400LA1</b>	(1) #4–250 kcmil Al/Cu, plus (1) 3/0–600 kcmil Al/Cu
		400	<b>TA401LA</b>	(1) 600–750 kcmil Al
		400	<b>TA401LA</b>	(1) 600–750 kcmil Al
LAM-600, LAMH-600, HLAM-600	Standard copper pressure terminals	600	<b>T600LA</b>	(2) 250–500 kcmil Cu
	Optional Al/Cu pressure terminals	600	<b>TA600LA</b>	(2) 250–500 kcmil Al/Cu
MAM, HMAM, MAMH	Standard copper pressure terminals	350	<b>T350MA</b>	(1) #1–600 kcmil Cu
		600	<b>T600MA1</b>	(2) 2/0–500 kcmil Cu
		800	<b>T800MA1</b>	(3) 3/0–300 kcmil Cu
	Optional Al/Cu pressure terminals	600	<b>TA700MA1</b>	(2) #1–500 kcmil Al/Cu
		800	<b>TA800MA2</b>	(3) 3/0–400 kcmil Al/Cu
		800	<b>TA801MA</b>	(2) 500–750 kcmil Al/Cu
NBM, HNBM, NBMH	Standard copper pressure terminals	1000	<b>T1000NB1</b>	(3) 3/0–500 kcmil Cu
		1200	<b>T1200NB1</b>	(4) 3/0–400 kcmil Cu
	Optional Al/Cu pressure terminals	1000	<b>TA1000NB1</b>	(3) 3/0–400 kcmil Al/Cu
		1200	<b>TA1200NB1</b>	(4) 4/0–500 kcmil Al/Cu
		1200	<b>TA1200NB1</b>	(4) 4/0–500 kcmil Al/Cu
		1200	<b>TA1201NB1</b>	(3) 500–750 kcmil Al/Cu

## Accessories

## Classic Mining Circuit Breakers

Rear Connected Studs <sup>①</sup>

For complete stud assembly, order a stud and tube based on thickness of customer's mounting panel. A short stud must be assembled adjacent to a long stud to maintain

clearances required by Underwriters Laboratories.<sup>②</sup> Two studs required per pole. For List Prices, see Eaton's Price and Availability Digest.

Mounting Panel Thickness In Inches (mm)	Stud		Tube	
	Length	Style Numbers	Length In Inches (mm)	Style Numbers
<b>KAM, HKAM Breakers</b>				
0.75 (19.1)–1.00 (25.4)	Short	<b>656D565G01</b>	0.84 (21.3)	<b>456D983H05</b>
	Long	<b>656D565G02</b>	3.78 (96.0)	<b>456D983H08</b>
0.50 (12.7)–0.75 (19.1)	Short	<b>656D565G01</b>	1.09 (27.7)	<b>456D983H06</b>
	Long	<b>656D565G02</b>	4.03 (102.4)	<b>456D983H09</b>
0.25 (6.4)–0.50 (12.7)	Short	<b>656D565G01</b>	1.34 (34.0)	<b>456D983H07</b>
	Long	<b>656D565G02</b>	4.28 (108.7)	<b>456D983H10</b>

## Rear Connected Studs For Insulated Panels Only: Two Per Pole

Stud Ampere Number	Diameter, In Inches (mm) and Thread	Extension Back of Breaker In Inches (mm)	Stud Style Numbers
<b>LAM, HLAM Breakers</b>			
225 <sup>③</sup>	0.50 (12.7)–13	3.22 (81.8)	<b>1241 345</b>
	0.50 (12.7)–13	6.28 (159.5)	<b>1241 346</b>
225 <sup>③④</sup>	0.50 (12.7)–13	4.97 (126.2)	<b>1241 392</b>
400 <sup>③</sup>	0.75 (19.1)–16	5.47 (138.9)	<b>05B7383G22</b>
	0.75 (19.1)–16	7.97 (202.4)	<b>05B7383G23</b>
	0.75 (19.1)–16	10.47 (265.9)	<b>05B7383G24</b>
600	1.00 (25.4)–12	5.91 (150.1)	<b>314C960G16</b>
	1.00 (25.4)–12	8.41 (213.6)	<b>314C960G17</b>
	1.00 (25.4)–12	10.91 (277.1)	<b>314C960G18</b>
<b>MAM, HMAM, MAMH Breakers</b>			
225	0.50 (12.7)–13	3.66 (93.0)	<b>314C960G01</b>
400	0.75 (19.1)–16	5.91 (150.1)	<b>314C960G04</b>
	0.75 (19.1)–16	8.41 (213.6)	<b>314C960G05</b>
	0.75 (19.1)–16	10.91 (277.1)	<b>314C960G06</b>
600	1.00 (25.4)–12	5.91 (150.1)	<b>314C960G07</b>
	1.00 (25.4)–12	8.41 (213.6)	<b>314C960G08</b>
	1.00 (25.4)–12	10.91 (277.1)	<b>314C960G09</b>
800	1.13 (28.7)–12	4.91 (124.7)	<b>314C960G10</b>
	1.13 (28.7)–12	8.41 (213.6)	<b>314C960G11</b>
	1.13 (28.7)–12	10.91 (277.1)	<b>314C960G12</b>
<b>NBM, HNB, NBMH Breakers</b>			
800	1.13 (28.7)–12	5.50 (139.7)	<b>623B222G01</b>
	1.13 (28.7)–12	8.00 (203.2)	<b>623B222G02</b>
	1.13 (28.7)–12	10.50 (266.7)	<b>623B222G03</b>
1200	1.25 (31.8)–12	5.50 (139.7)	<b>373B375G04</b>
	1.25 (31.8)–12	10.50 (266.7)	<b>373B375G03</b>

Line and Load Terminal Shields <sup>⑤</sup>

Breaker Type	Description	Style Numbers
KAM	Line terminals	<b>1261C93G01</b>
	Load terminals	<b>1262C46G01</b>
LAM-400	Line terminals	<b>1261C95G01</b>
	Load terminals	<b>1262C48G01</b>
MAM	Line terminals	<b>1261C97G01</b>
	Load terminals	<b>1261C97G02</b>

## Notes

- ① Not UL listed.
- ② 400 ampere LA studs of the same length have sufficient clearance; however, customer connections may make it necessary to use a short stud adjacent to a long stud.
- ③ 150, 300 and 400 ampere frames only.
- ④ This is a special stud that includes six contact nuts for use where bus contact nuts must be used.
- ⑤ For breakers used with terminals and cable connections. Sold in packages of 10.

**Standard Handle Reset Undervoltage Release**

For Classic breakers field mountable on special frames listed on **Page V4-T2-412**, or replacement on breakers originally equipped with this type UVR.

For undervoltage protection. A solenoid device mounts within breaker case. Coil must be energized before closing breaker. Trips breaker

when voltage drops below 35 to 70% of coil rating. Picks up and seals in at 72 to 85% of coil rating. For line voltages up to 250 Vdc or 600 Vac. Externally mounted resistors are supplied for certain ratings. Standard leads extend 18.00 inches (457.2 mm) outside of breaker. Longer leads may be specified.

Breaker Type	Volts	Style Numbers
<b>Right-Hand Mounting</b>		
LAM, HLAM	120 Vac	<b>4995D12G11</b>
	120 Vac <sup>①</sup>	<b>1228C76G03</b>
	240 Vac	<b>4995D12G13</b>
	480 Vac	<b>4995D12G14</b>
	125 Vdc	<b>4995D12G09</b>
MAM, HMAM, MAMH	120 Vac	<b>5672D69G11</b>
	120 Vac <sup>①</sup>	—
	240 Vac	<b>5672D69G13</b>
	480 Vac	<b>5672D69G14</b>
NBM, HNBM, NBMH	120 Vac	<b>4995D11G11</b>
	120 Vac <sup>①</sup>	<b>1229C35G03</b>
	240 Vac	<b>4995D11G13</b>
	480 Vac	<b>4995D11G14</b>
<b>Left-Hand Mounting</b>		
KAM, HKAM	120 Vac	<b>4995D10G01</b>
	120 Vac <sup>①</sup>	<b>1228C76G03</b>
	240 Vac	<b>4995D10G03</b>
	480 Vac	<b>4995D10G04</b>

**Shunt Trips**

For tripping breaker from a remote point. A solenoid device mounts within breaker case. Breaker trips when coil is energized. A cutoff switch breaks the circuit to the momentary rated coil when breaker opens. Available for

control voltages up to 250 Vdc or 600 Vac. Voltage and frequency must be specified. Standard leads extend 18.00 inches (457.2 mm) outside of breaker. Longer leads may be specified.

Breaker Type	Volts (50–60 Hz)	Style Numbers
<b>Right-Hand Mounting</b>		
KAM, HKAM	480 Vac	<b>2605D15G16</b>
	240 Vac	<b>2605D15G17</b>
	120 Vac	<b>2605D15G19</b>
LAM, HLAM	480 Vac	<b>2606D56G16</b>
	240 Vac	<b>2606D56G17</b>
	120 Vac	<b>2606D56G19</b>
	48 Vdc	<b>2606D56G07</b>
MAM, HMAM, MAMH	480 Vac	<b>2606D57G16</b>
	240 Vac	<b>2606D57G17</b>
	120 Vac	<b>2606D57G19</b>
NBM, HNBM, NBMH	480 Vac	<b>2606D58G16</b>
	240 Vac	<b>2606D58G17</b>
	120 Vac	<b>2606D58G19</b>
<b>Left-Hand Mounting</b>		
KAM, HKAM	480 Vac	<b>2605D15G02</b>
	240 Vac	<b>2605D15G03</b>
	120 Vac	<b>2605D15G05</b>
LAM, HLAM	480 Vac	<b>2606D56G02</b>
	240 Vac	<b>2606D56G03</b>
	120 Vac	<b>2606D56G05</b>
MAM, HMAM, MAMH	480 Vac	<b>2606D57G02</b>
	240 Vac	<b>2606D57G03</b>
	120 Vac	<b>2606D57G05</b>
NBM, HNBM, NBMH	480 Vac	<b>2606D58G02</b>
	240 Vac	<b>2606D58G03</b>
	120 Vac	<b>2606D58G05</b>

**Notes**

- ① Electrical reset UVR.
- ② Auto reset type.

## Reference Information

2

E<sup>2</sup> Cross-Reference

Series C Mining	Superseded by E <sup>2</sup> Mining
1491D72G31	E2J3070T
1491D72G32	E2J3090T
1491D72G33	E2J3100T
1491D72G37	E2J3200T
6622C87G27	E2K3225AWU66
6622C87G28	E2K3225DWU66
6622C87G32	E2K3400GWU66
E2KM3100	E2KEM3100W
E2KM3100U66	E2KEM3100WU66
E2KM3125	E2KEM3125W
E2KM3125U66	E2KEM3125WU66
E2KM3150	E2KEM3150W
E2KM3150MU66	E2KEM3150WU66
E2KM3150TM	E2KEM3150MW
E2KM3150U66	E2KEM3150MWU66
E2KM3200	E2KEM3200W
E2KM3200U66	E2KEM3200WU66
E2KM3225	E2KEM3225W
E2KM3225F	E2KM3400F
E2KM3225FUV	E2KM3400F
E2KM3225MU66	E2KEM3225MWU66
E2KM3225TM	E2KEM3225TM
E2KM3225U66	E2KEM3225WU66
E2LM3300U66	E2LEM3300WU66
E2LM3350U66	E2LEM3350WU66
E2LM3400U66	E2LEM3400WU66
E2LM3400F	E2LM3600F
E2LM3400FUV	E2LM3600F
E2LM3400M2U66	E2LEM3400M2WU66
E2LM3400MU66	E2LEM3400MWU66
E2LM3400U66	E2LEM3400WU66
FDBM3015	E2F3015
FDBM3015WU62	E2F3015WU62
FDBM3020	E2F3020
FDBM3025	E2F3025
FDBM3025U62	E2F3025U62
FDBM3030	E2F3030
FDBM3030U62	E2F3030WU62
FDBM3030WU62	E2F3030WU62
FDBM3035	E2F3035

Series C Mining	Superseded by E <sup>2</sup> Mining
FDBM3040	E2F3040
FDBM3045	E2F3045
FDBM3050	E2F3050
FDBM3050U62	E2F3050U62
FDBM3050WU62	E2F3050WU62
FDBM3060	E2F3060
FDBM3070	E2F3070
FDBM3070WU62	E2F3070WU62
FDBM3080	E2F3080
FDBM3090	E2F3090
FDBM3100	E2F3100
FDBM3100LM04U62	E2F3100M04U62
FDBM3125	E2F3125
FDBM3150	E2F3150
FDBM3150L	E2F3150L
FDM3015	E2F3015
FDM3015L	E2F3015L
FDM3015LU62	E2F3015LU62
FDM3020	E2F3020
FDM3020LU62	E2F3020LU62
FDM3025	E2F3025
FDM3025L	E2F3025L
FDM3025LS22	E2F3025LS22
FDM3025LU62	E2F3025LU62
FDM3030	E2F3030
FDM3030LS22	E2F3030LS22
FDM3040	E2F3040
FDM3040L	E2F3040L
FDM3040LU62	E2F3040LU62
FDM3050	E2F3050
FDM3050LU62	E2F3050LU62
FDM3050U62	E2F3050U62
FDM3060	E2F3060
FDM3060LU62	E2F3060LU62
FDM3070	E2F3070
FDM3070A02U62	E2F3070A02U62
FDM3080	E2F3080
FDM3090	E2F3090
FDM3100	E2F3100
FDM3100LS22	E2F3100LS22

E<sup>2</sup> Cross-Reference, continued

Series C Mining	Superseded by E <sup>2</sup> Mining
FDM3100LU62	E2FLU62
FDM3125	E2F3125
FDM3125LU62	E2F3125LU62
FDM3150	E2F3150
HFD003AM	E2F003AM
HFD003AMLU62	E2F003AMLU62
HFD007CM	E2F007CM
HFD007CMU62	E2F007CMU62
HFD015EM	E2F015EM
HFD015EMA02	E2F015EMA02
HFD015EMLU62	E2F015EMLU62
HFD015EMU62	E2F015EMU62
HFD030HM	E2F030HM
HFD030HMLU62	E2F030HMLU62
HFD030HMU62	E2F030HMU62
HFD050KM	E2F050KM
HFD050KML	E2F050KML
HFD050KMLU62	E2F050KMLU62
HFD050KMU62	E2F050KMU62
HFD070MM	E2F070MM
HFD070MMU62	E2F070MMU62
HFD01001M	E2F1001M
HFD01001MS22	E2F1001MS22
HFD0100LM	E2F100LM
HFD0100LMA02	E2F100LMA02
HFD0100LMU62	E2F100LMU62
HFD0100RM	E2F100RM
HFD0100RML	E2F100RML
HFD0100RMS22	E2F100RMS22
HFD0100RMU62	E2F100RMU62
HFD0150TM	E2F150TM
HFD0150TML	E2F150TML
HFD0150TMU62	E2F150TMU62
HFD0150UM	E2F150UM
JCDA2D1S30	E2JM250MDA2D1S30
JCMA2D1S30	E2JM250MFA2D1S30
JDCM3070W	E2JM3070W
JDCM3090W	E2JM3090W
JDCM3100W	E2JM3100W
JDCM3125W	E2JM3125W

Series C Mining	Superseded by E <sup>2</sup> Mining
JDCM3150W	E2JM3150W
JDCM3175W	E2JM3175W
JDCM3200W	E2JM3200W
JDCM3225A5W	E2JM3225AW
JDCM3225D5W	E2JM3225DW
JDCM3225W	E2JM3225W
JDCM3250A5MW	E2JM3250MAW
JDCM3250A5MWU18	E2JM3250MAWU18
JDCM3250A5W	E2JM3250AW
JDCM3250C5MW	E2JM3250MCW
JDCM3250D5MW	E2JM3250MDW
JDCM3250D5MWA06	E2JM3250MDWA06
JDCM3250D5W	E2JM3250DW
JDCM3250D5WS10	E2JM3250DWS10
JDCM3250F	E2JM3250F
JDCM3250F5MD01	E2JM3250MFD01
JDCM3250F5MW	E2JM3250MFW
JDCM3250G5MW	E2JM3250MGW
JDCM3250G5WA02D01	E2JM3250MGA02D01
JDCM3250J5MW	E2JM3250MJW
JDCM3250J5MWA02	E2JM3250MJA02
JDCM3250J5WA02D01	E2JM3250MJA02D01
JDCM3250J5WD01	E2JM3250MJD01
JDCM3250K5MW	E2JM3250MKW
JDCM3250L5MW	E2JM3250MLW
JDCM3250MW	E2JM3250MW
JDCM3250W	E2JM3250W
JDCMAA2D1	E2JM3250MM02D01
JDCMDD1S30	E2JM3250MDS30D01
JDCMFD01	E2JM3250MFD01
JDCMGA02D1	E2JM3250MGA02D01
JDCMJA2D1	E2JM3250MJA02D01
JDCMJD01	E2JM3250MJD01
JDM2250F	E2JM3250F
JDM3070W	E2J3070W
JDM3090W	E2J3090W
JDM3100W	E2J3100W
JDM3125W	E2J3125W
JDM3150W	E2J3150W
JDM3150WU18	E2J3150WU18

# 2.6

## Molded Case Circuit Breakers

### Specialty Breakers

#### E<sup>2</sup> Cross-Reference, continued

2

Series C Mining	Superseded by E <sup>2</sup> Mining
JDM3175W	E2J3175W
JDM3200W	E2J3200W
JDM3200WA06	E2J3200WA06
JDM3225A5W	E2J3225AW
JDM3225D5W	E2J3225DW
JDM3225W	E2J3225W
JDM3250A5MW	E2J3250MAW
JDM3250A5W	E2J3250AW
JDM3250C5MW	E2J3250CW
JDM3250D5MW	E2J3250MDW
JDM3250D5W	E2J3250DW
JDM3250F	E2J3250F
JDM3250F5MW	E2J3250MFW
JDM3250G5MW	E2J3250MGW
JDM3250J5MW	E2J3250MJW
JDM3250K5MW	E2J3250MKW
JDM3250L5MW	E2J3250MLW
JDM3250MW	E2J3250MW
JDM3250W	E2J3250W
JDM3250WS10	E2J3250WS10
JM2225T1125-2250	E2J3225T
JM3070T	E2J3070T
JM3090T	E2J3090T
JM3100T	E2J3100T
JM3125T	E2J3125T
JM3150T	E2J3150T
JM3175T	E2J3175T
JM3200T	E2J3200T
JM3225T	E2J3225T
JM3225TA5	E2J3225TA
JM3225TD5	E2J3225TD
JM3250T	E2J3250T
JM3250TA5	E2J3250TA
JM3250TA5M_350-700	E2J3250TMA
JM3250TC5M	E2J3250TMC
JM3250TD5_500-1000	E2J3250TMD
JM3250TF5M_625-1250	E2J3250TMF
JM3250TG5M_750-1500	E2J3250TMG
JM3250TJ5M_875-1750	E2J3250TMJ
JM3250TK5M_1000-2000	E2J3250TMK

Series C Mining	Superseded by E <sup>2</sup> Mining
JM3250TL5M_1125-2250	E2J3250TML
JM3250TM	E2J3250TM
KDCM3100W	E2KM3100W
KDCM3125W	E2KM3125W
KDCM3150W	E2KM3150W
KDCM3175W	E2KM3175W
KDCM3200W	E2KM3200W
KDCM3225A5MW	E2KM3200MAW
KDCM3225D5MW	E2KM3200MDW
KDCM3225W	E2KM3225W
KDCM3250W	E2KM3250W
KDCM3250WU18	E2KM3250WU18
KDCM3300W	E2KM3300W
KDCM3350W	E2KM3350W
KDCM3400D5MA02D09H04	E2KM3400MDA02D09H04
KDCM3400D5MW	E2KM3400MDW
KDCM3400D5MWA02D07	E2KM3400MDA02D07
KDCM3400D5W	E2KM3400DW
KDCM3400D5WD09	E2KM3400DD09
KDCM3400F	E2KM3400F
KDCM3400F5MW	E2KM3400MFW
KDCM3400FD09G04	E2KM3400MFD09G04
KDCM3400G5MW	E2KM3400MGD09G05
KDCM3400G5MWD09H04	E2KM3400MGD09H04
KDCM3400G5W	E2KM3400MGW
KDCM3400G5WD07	E2KM3400MGD07
KDCM3400J5MA02D09	E2KM3400MJA02D09
KDCM3400J5MA2D9G4S30	E2KM3400MJA2D9G4S30
KDCM3400J5MD09	E2KM3400MJD09
KDCM3400J5MD09H04S30	E2KM3400MJD09H04S30
KDCM3400J5MW	E2KM3400MJW
KDCM3400J5MWA02D07	E2KM3400MJA02D07
KDCM3400J5MWA06	E2KM3400MJWA06
KDCM3400J5MWD07S30	E2KM3400MJD07S30
KDCM3400J5WD07	E2KM3400MJD07
KDCM3400K5MW	E2KM3400MKW
KDCM3400K5MWS10	E2KM3400MKWS10
KDCM3400K5MWU18	E2KM3400MKWU18
KDCM3400L5MW	E2KM3400MLW
KDCM3400L5MWD09H04	E2KM3400MLD09H04

E<sup>2</sup> Cross-Reference, continued

Series C Mining	Superseded by E <sup>2</sup> Mining
KDCM3400L5MWS10	E2KM3400MLWS10
KDCM3400L5WD07	E2KM3400MLD07
KDCM3400MW	E2KM3400MW
KDCM3400N5MW	E2KM3400MNW
KDCM3400N5MWA06	E2KM3400MNWA06
KDCM3400N5WA02D07	E2KM3400MNA02D07
KDCM3400R5MW	E2KM3400MRW
KDCM3400W	E2KM3400W
KDCM3400W5MW	E2KM3400MWW
KDCMDMD07	E2KM3400MDD07
KDCMNA2D7	E2KM3400MNA02D07
KDM2400F	E2K2400F
KDM2400G5MS50	E2K2400MGWS50
KDM2400G5MW	E2K2400MGW
KDM2400W5MW	E2K2400MWW
KDM2400W5MWA06D07S10	E2K2400MWA06D07S10
KDM2400W5MWA06D10S10	E2K2400MWA06D10S10
KDM2400W5MWD07	E2K2400MWD07
KDM2400W5MWD07S10	E2K2400MWD07S10
KDM2400W5MWD10	E2K2400MWD10
KDM2400W5MWD10S10	E2K2400MWD10S10
KDM2400W5MWS10	E2K2400MWS10
KDM3100W	E2K3100W
KDM3125W	E2K3125W
KDM3150W	E2K3150W
KDM3150WA06	E2K3150WA06
KDM3175W	E2K3175W
KDM3200W	E2K3200W
KDM3225A5W	E2K3225AW
KDM3225D5A13D09U18	E2K3225DA13D09U18
KDM3225D5MW	E2K3400MDW
KDM3225D5W	E2K3225DW
KDM3225F	E2K3400F
KDM3225W	E2K3225W
KDM3225WK37	E2KE3225W
KDM3225WK37U18	E2KE3225WU18
KDM3225WK38	E2KE3225MW
KDM3250W	E2K3250W
KDM3300W	E2K3300W
KDM3300WA06U18	E2K3300WA06U18

Series C Mining	Superseded by E <sup>2</sup> Mining
KDM3300WS10	E2K3300WS10
KDM3350W	E2K3350W
KDM3400D5MW	E2K3400MDW
KDM3400D5W	E2K3400DW
KDM3400D5WU18	E2K3400DWU18
KDM3400F	E2K3400F
KDM3400F5MW	E2K3400MFW
KDM3400FK37A06D09D18	E2KE3400A06D09D18
KDM3400G5A06D09U18	E2K3400GA06D09U18
KDM3400G5A13D09U18	E2K3400GA13D09U18
KDM3400G5MW	E2K3400MGW
KDM3400G5W	E2K3400GW
KDM3400G5WA06	E2K3400GWS10
KDM3400G5WS10	E2K3400GWS10
KDM3400G5WU18	E2K3400GWU18
KDM3400J5MW	E2K3400MJW
KDM3400K5MS54	E2K3400MKWS54
KDM3400K5MW	E2K3400MKW
KDM3400L5MW	E2K3400MLW
KDM3400MW	E2K3400MW
KDM3400MWA06U18	E2K3400MWA06U18
KDM3400N5MW	E2K3400MNW
KDM3400R5MW	E2K3400MRW
KDM3400W	E2K3400W
KDM3400W5MW	E2K3400MWW
KEM3100T	KEM3100T
KEM3125T	KEM3125T
KEM3150T	KEM3150T
KEM3150TM	KEM3150TM
KEM3200T	KEM3200T
KEM3225T	KEM3225T
KEM3225T2	KEM3225T2
KEM3225TM	KEM3225TM
KEM3225TM2	KEM3225TM2
KM2225TA5	E2K2225TA
KM2225TA5M	E2K2400TMA
KM2225TD5	E2K2225TD
KM2225TD5M	E2K2400TMD
KM2400TD5	E2K2400TD
KM2400TD5M	E2K2400TMD

E<sup>2</sup> Cross-Reference, continued

2

Series C Mining	Superseded by E <sup>2</sup> Mining
KM2400TG5M	E2K2400TMG
KM2400TN5M	E2K2400TMN
KM2400TW5M	E2K2400TMW
KM3100T	E2K3100T
KM3125T	E2K3125T
KM3150T	E2K3150T
KM3175T	E2K3175T
KM3200T	E2K3200T
KM3225T	E2K3225T
KM3225TA5	E2K3225TA
KM3225TA5M	E2K3400TMA
KM3225TD5	E2K3225TD
KM3225TD5M	E2K3400TMD
KM3250T	E2K3250T
KM3300T	E2K3300T
KM3350T	E2K3350T
KM3400T	E2K3400T
KM3400TD5	E2K3400TD
KM3400TF5M	E2K3400TFM
KM3400TG5M	E2K3400TMG
KM3400TJ5M	E2K3400TMJ
KM3400TK5M	E2K3400TMK
KM3400TL5M	E2K3400TML
KM3400TM	E2K3400TM
KM3400TN5M	E2K3400TMN
KM3400TR5M	E2K3400TMR
KM3400TW5M	E2K3400TMW
LDCM3600EMA05W	E2LEM3600MA05W
LDCM3600F	E2LM3600F
LDM3600F	E2L3600F

Series C Mining	Superseded by E <sup>2</sup> Mining
LEM3300T	LEM3300T
LEM3350T	LEM3350T
LEM3400T	LEM3400T
LEM3400T2	LEM3400T2
LEM3400TM	LEM3400TM
LEM3400TM2	LEM3400TM2
LEM3600T	LEM3600T
LEM3600TM	LEM3600TM
LM3600TL6M	E2L3600TML
LM3600TN6M	E2L3600TMN
LM3600TP6M	E2L3600TMP
LM3600TR6M	E2L3600TMR
LM3600TS6M	E2L3600TM
LM3600TX6M	E2L3600TMX
UVE3LP08K	UVE3LP08K
UVE4LP08K	UVE4LP08K

## Additional Information on Mining Breakers

Source	Description
TD01217001E	E <sup>2</sup> Mining Circuit Breaker Dimensional Data
BR01217001E	E <sup>2</sup> Mining Circuit Breaker Brochure
TC01217001E	E <sup>2</sup> Mining Circuit Breaker Time Current Curves
<a href="http://www.eaton.com/mining">www.eaton.com/mining</a>	Mining and Metals

## GFR Relay



## Add-On Ground Fault Protection—Type GFR

## Product Description

A Type GFR ground fault protection system, when properly installed on a grounded electrical system, will sense phase-to-ground fault currents. When the level of fault current is in excess of the pre-selected current pickup and time delay settings, the GFR relay will initiate a trip action of a disconnect device, which will open the faulted circuit and clear the fault.

The GFR devices are UL Class I devices designed to protect electrical equipment against extensive damage from arcing ground faults.

A basic Type GFR ground fault protection system consists of a ground fault relay, a ground fault current sensor and a disconnect device equipped with a shunt trip device. This disconnect device can be a molded case circuit breaker, a power circuit breaker, a bolted pressure switch or other fusible disconnect device, suitable for application with UL Class I ground fault sensing and relaying equipment.

**Note:** Suitable for either surface or semi-flush mounting.

## Contents

## Description

	<i>Page</i>
Engine Generator Circuit Breakers . . . . .	<b>V4-T2-341</b>
Direct Current Circuit Breakers. . . . .	<b>V4-T2-347</b>
PVGard Solar Circuit Breakers—600 Vdc Per-Pole and 1000 Vdc Poles-in-Series. . . . .	<b>V4-T2-361</b>
E <sup>2</sup> Mining Service Circuit Breakers . . . . .	<b>V4-T2-374</b>
Classic Mining Breakers. . . . .	<b>V4-T2-403</b>
E2VAC Mining Vacuum Circuit Breaker . . . . .	<b>V4-T2-400</b>
Add-On Ground Fault Protection—Type GFR	
Product Selection . . . . .	<b>V4-T2-418</b>
Accessories . . . . .	<b>V4-T2-419</b>
Technical Data and Specifications . . . . .	<b>V4-T2-419</b>

## Standards and Certifications

Eaton's GFR ground fault relays, current sensors, test panels and accessory devices are UL listed by Underwriters Laboratories in accordance with their standard for ground fault sensing and relaying equipment, UL 1053, under File E48381.

**Note:** Relays are also listed with CSA under their file number 43357.



# 2.6

## Molded Case Circuit Breakers

### Specialty Breakers

2

#### Product Selection

Each installation requires:

- One relay unit (select trip ampere as required)
- One current sensor (select configuration required)
- One circuit breaker or disconnect device with shunt trip, or a shunt trip attachment for mounting in existing breaker
- Test panel (optional)

#### GFR Relay



#### GFR Relay

##### GFR Relay Types

##### Ground Fault Pickup Amperes

	1–12 Catalog Number ①	5–60 Catalog Number ①	100–1200 Catalog Number ①
<b>For 120 Volt 50/60 Hz Control</b>			
Electrical reset with zone interlocking	GFR12EI	GFR60EI	GFR1200EI
Electrical reset without zone interlocking	GFR12E	GFR60E	GFR1200E
Mechanical reset with zone interlocking	GFR12MI	GFR60MI	GFR1200MI
Mechanical reset without zone interlocking	GFR12M	GFR60M	GFR1200M
<b>For 120 Vdc Control</b>			
Electrical reset with zone interlocking	—	—	GFR1200EID
Electrical reset without zone interlocking	—	—	GFR1200ED
Mechanical reset with zone interlocking	—	—	GFR1200MID
Mechanical reset without zone interlocking	—	—	GFR1200MD

#### Typical Current Sensor



#### Current Sensor

Window Size in Inches (mm)	Catalog Number
<b>Used with Relays Rated 1–12 Amperes</b>	
5.50 (139.7) I.D.	1283C45G01
<b>Used with Relays Rated 5–60 Amperes</b>	
2.50 (63.5) I.D.	179C768G01
5.50 (139.7) I.D.	1256C13G01
7.81 x 11.00 (198.4 x 279.4) Rect. ②	1257C88G04
3.31 x 24.94 (84.1 x 760.5) Rect. ②	1257C92G03
<b>Used with Relays Rated 100–1200 Amperes</b>	
2.50 (63.5) I.D.	179C768G02
5.50 (139.7) I.D.	1256C13G02
8.25 (209.6) I.D.	179C767G02
7.81 x 11.00 (198.4 x 279.4) Rect. ②	1257C88G03
9.94 x 16.94 (252.5 x 430.3) Rect. ②	1257C90G02
9.94 x 23.94 (252.5 x 608.1) Rect. ②	1257C91G02
15.94 x 19.94 (404.9 x 506.4) Rect. ②	1257C89G02
3.31 x 24.94 (84.1 x 633.5) Rect. ②	1257C92G04
6.75 x 29.64 (171.5 x 752.9) Rect. ②	1255C39G03

#### Notes

- ① Suitable for either surface or semi-flush mounting.
- ② One end removable for installation.

## Accessories

### Options

Additional optional equipment can be added to the protection system to meet the requirements of the specifying engineer, including:

- Ground fault test panel
- Ground fault warning indicator relay
- Ground fault indicating ammeter

GFR relays are available with zone selective interlocking circuitry to interlock several relays within the same system. This allows the relay which detects a ground fault to instantly clear the fault by tripping the disconnect device. The relay simultaneously sends a signal to relay units “upstream” from the fault to time delay or to block their operation completely. Current sensors in various designs provide a range of “window” sizes to accommodate standard bus and cable arrangements.

Shunt trip attachments may be ordered for field mounting in Eaton’s molded case circuit breakers, or may be ordered factory installed in the breaker.

### Test Panel (120 Vac)

Used to test the ground fault system, to give an indication the relay has tripped the breaker, and to reset the relay after tripping. These functions may be separately mounted pilot devices.

**Note:** When a mechanically reset relay is used with a test panel, both the relay and test panel must be reset following either a simulated ground fault test or actual ground fault. Not UL listed.

### Optional Test Panel

Control	Test	Catalog Number
120 Volt 50/60 Hz	120 Volt 50/60 Hz	<b>GFRTP</b>

### Ground Fault Warning Indicator

This is an accessory item for use with GFR relays with interlocking circuitry. At approximately 30–50% of the relay pickup setting, the indicator switches separate 120 Vac control power to a lamp or relay, (not included) to give an indication of a ground fault. The indicator is rated 110/120 Vac 50/60 Hz for a maximum indicator load of 0.5 amperes.

### Ground Fault Warning Indicator

Description	Catalog Number
Manual reset	<b>1234C67G01</b>
Self-resetting	<b>1234C67G02</b>

### Indicating Ammeter

The optional indicating ammeter connects to the sensor terminals through a momentary contact pushbutton, and will indicate (in amperes) any ground fault current flowing through the sensor. Kit includes the ammeter and pushbutton.

**Note:** Not UL listed.

### Ammeter Kit

GFR System Used with	Kit Catalog Number
1–12 ampere	<b>752B820G01</b>
5–60 ampere	<b>752B820G02</b>
100–1200 ampere	<b>752B820G03</b>

### Shunt Trip Attachments

Use 120 Vac shunt trips.

### Faceplate

Recommended when these relays are semi-flush mounted, to close the door cutout opening.

### Face Plate

Description	Catalog Number
Faceplate	<b>752B410G01</b>

## Technical Data and Specifications

### Sensor

- 600 volt, 50/60 Hz maximum system voltage

### Electrical Ratings

#### GFR Relay

- Ground fault detection ranges:
  - 1 to 12, 5 to 60 or 100 to 1200 amperes
- Output contacts:
  - 240 volt, 50/60 Hz: 3.0 amperes
  - 120 volt, 50/60 Hz: 6.0 amperes
  - 28 Vdc: 3.0 amperes
  - 125 Vdc: 0.5 amperes
- Control power requirements:
  - 120 volt, 50/60 Hz or 125 Vdc (optional)

#### Handle Mechanisms

2



#### Contents

##### Description

##### Page

Handle Mechanisms—Series G	
High-Performance Rotary Handle Mechanisms . . .	<b>V4-T2-421</b>
Universal Rotary . . . . .	<b>V4-T2-426</b>
Direct (Close-Coupled) Handle Mechanisms . . .	<b>V4-T2-428</b>
Flex Shaft. . . . .	<b>V4-T2-429</b>
Handle Mechanisms—Series C	
High-Performance Rotary Handle Mechanisms..	<b>V4-T2-434</b>
Series C Rotary . . . . .	<b>V4-T2-438</b>
Universal Rotary . . . . .	<b>V4-T2-440</b>
Direct (Close-Coupled) Handle Mechanisms . . .	<b>V4-T2-442</b>
Flex Shaft. . . . .	<b>V4-T2-444</b>
Handle Extension . . . . .	<b>V4-T2-447</b>

### Handle Mechanisms—Series G

#### Product Overview

Handle mechanisms are used to operate molded case circuit breakers, molded case switches and motor circuit protectors. They are available in three basic configurations—Flange Mounted, Through-the-Door and Direct (Close-Coupled)—providing safe, dependable operation and ease of installation.

#### Through-the-Door

- High-Performance Rotary
- Universal Rotary

#### Direct (Close-Coupled)

- Universal Direct

#### Flange Mounted

- Flex Shaft™

Handle mechanisms are used on enclosed circuit breakers, control panels and motor control centers in many different applications. Eaton has a handle mechanism for virtually any need.

## Handle Mechanisms



## High-Performance Rotary Handle Mechanisms

### Product Description

The high-performance rotary handle mechanism uses a simple, yet robust design to make installation and operation easy. The external handle's key functional components are all metallic, ensuring reliability. The metal-on-metal interface between the handle and shaft prevents contaminant buildup that could impede operation, while UV and chemical agent resistant materials protect the handle from heat and fading in direct sunlight, as well as chemicals that may be introduced in harsh environments.

In addition to its robust design features, the handle mechanism has stand-off support that allows for easy operation with a gloved hand. With a shallow profile, the handle can easily be used in applications where an internal or double door is required.

The high-performance external handle can accept padlocks or multi-hasps locks. The door is interlocked when padlocked and cannot be bypassed.

### Description

	<i>Page</i>
Handle Mechanisms—Series G . . . . .	<b>V4-T2-420</b>
High-Performance Rotary Handle Mechanisms	
Product Selection . . . . .	<b>V4-T2-422</b>
Dimensions . . . . .	<b>V4-T2-425</b>
Universal Rotary . . . . .	<b>V4-T2-426</b>
Direct (Close-Coupled) Handle Mechanisms . . .	<b>V4-T2-428</b>
Flex Shaft . . . . .	<b>V4-T2-429</b>
Handle Mechanisms—Series C	
High-Performance Rotary Handle Mechanisms .	<b>V4-T2-434</b>
Series C Rotary . . . . .	<b>V4-T2-438</b>
Universal Rotary . . . . .	<b>V4-T2-440</b>
Direct (Close-Coupled) Handle Mechanisms . . .	<b>V4-T2-442</b>
Flex Shaft . . . . .	<b>V4-T2-444</b>
Handle Extension . . . . .	<b>V4-T2-447</b>

### Features

- NEMA Type 1/3R/12 (IP54) and NEMA Type 4/4X (IP65) ratings
- Black/Blue or Red/Yellow external handle colors
- Three shaft lengths—6, 12 and 24 inches, which can be cut to size to match enclosure depth
- Conveniently packaged as kit containing handle, shaft and mechanism
- Replacement parts are available separately
- Metallic functional components ensure reliability
- Metal-on-metal interface between handle and shaft
- UV and chemical agent-resistant materials protect the handle
- Shallow profile
- Compatible with both Series C and Series G molded case circuit breakers and molded case switch platforms
- Same handle can be used on multiple frame sizes, reducing the number of parts needed
- Red and yellow handles to designate emergency disconnecting means
- All handle mechanisms can accept padlocks or multi-hasps locks for added flexibility
- Fast, easy installation (see video on website for step-by-step instructions)

### Standards and Certifications

The mechanisms for EG, JG and LG breakers have an internal handle that can be operated independent of door position, and locked-out to meet one of the key NFPA requirements (NFPA® 79) and UL 508A disconnect requirements.

- NEMA 1/3R/12, IP54
- NEMA 4/4X, IP65







## Product Selection

## Handle Mechanisms for Series G Frames

2

## Kits Only (Kit Includes Shaft, Mechanism and Handle)—EG-, JG- and LG-Frame





Description	Rating Type		EG-Frame Catalog Number	JG-Frame Catalog Number	LG-Frame Catalog Number	
	NEMA	IP				
<b>S01 Blue Handle</b> 	S01 blue handle, 6-inch shaft	1/3R/12	54	EGHMVD06B0 / 68C6040G25	JGHMVD06B0 / 68C6041G13	—
		4/4X	65	EGHMVD06BX0 / 68C6040G28	JGHMVD06BX0 / 68C6041G16	—
	S01 blue handle, 12-inch shaft	1/3R/12	54	EGHMVD12B0 / 68C6040G26	JGHMVD12B0 / 68C6041G14	—
		4/4X	65	EGHMVD12BX0 / 68C6040G29	JGHMVD12BX0 / 68C6041G17	—
S01 blue handle, 24-inch shaft ①	1/3R/12	54	EGHMVD24B0 / 68C6040G27	JGHMVD24B0 / 68C6041G15	—	
	4/4X	65	EGHMVD24BX0 / 68C6040G30	JGHMVD24BX0 / 68C6041G18	—	
<b>S01 Red Handle</b> 	S01 red handle, 6-inch shaft	1/3R/12	54	EGHMVD06R0 / 68C6040G31	JGHMVD06R0 / 68C6041G19	—
		4/4X	65	EGHMVD06RX0 / 68C6040G34	JGHMVD06RX0 / 68C6041G22	—
	S01 red handle, 12-inch shaft	1/3R/12	54	EGHMVD12R0 / 68C6040G32	JGHMVD12R0 / 68C6041G20	—
		4/4X	65	EGHMVD12RX0 / 68C6040G35	JGHMVD12RX0 / 68C6041G23	—
S01 red handle, 24-inch shaft ①	1/3R/12	54	EGHMVD24R0 / 68C6040G33	JGHMVD24R0 / 68C6041G21	—	
	4/4X	65	EGHMVD24RX0 / 68C6040G36	JGHMVD24RX0 / 68C6041G24	—	
<b>S2 Blue Handle</b> 	S2 blue handle, 6-inch shaft	1/3R/12	54	EGHMVD06B / 68C6040G13	JGHMVD06B / 68C6041G01	LGHMVD06B / 68C6042G01
		4/4X	65	EGHMVD06BX / 68C6040G16	JGHMVD06BX / 68C6041G04	LGHMVD06BX / 68C6042G04
	S2 blue handle, 12-inch shaft	1/3R/12	54	EGHMVD12B / 68C6040G14	JGHMVD12B / 68C6041G02	LGHMVD12B / 68C6042G02
		4/4X	65	EGHMVD12BX / 68C6040G17	JGHMVD12BX / 68C6041G05	LGHMVD12BX / 68C6042G05
S2 blue handle, 24-inch shaft ①	1/3R/12	54	EGHMVD24B / 68C6040G15	JGHMVD24B / 68C6041G03	LGHMVD24B / 68C6042G03	
	4/4X	65	EGHMVD24BX / 68C6040G18	JGHMVD24BX / 68C6041G06	LGHMVD24BX / 68C6042G06	
<b>S2 Red Handle</b> 	S2 red handle, 6-inch shaft	1/3R/12	54	EGHMVD06R / 68C6040G19	JGHMVD06R / 68C6041G07	LGHMVD06R / 68C6042G07
		4/4X	65	EGHMVD06RX / 68C6040G22	JGHMVD06RX / 68C6041G10	LGHMVD06RX / 68C6042G10
	S2 red handle, 12-inch shaft	1/3R/12	54	EGHMVD12R / 68C6040G20	JGHMVD12R / 68C6041G08	LGHMVD12R / 68C6042G08
		4/4X	65	EGHMVD12RX / 68C6040G23	JGHMVD12RX / 68C6041G11	LGHMVD12RX / 68C6042G11
S2 red handle, 24-inch shaft ①	1/3R/12	54	EGHMVD24R / 68C6040G21	JGHMVD24R / 68C6041G09	LGHMVD24R / 68C6042G09	
	4/4X	65	EGHMVD24RX / 68C6040G24	JGHMVD24RX / 68C6041G12	LGHMVD24RX / 68C6042G12	

**Notes**

① 24-inch handle comes with support bracket.

Shaft guide (68C6048G49) is optional and can be used with any high-performance handle listed above for greater alignment tolerance.

**Handle Mechanisms for Series G Frames****Kits Only (Kit Includes Shaft, Mechanism and Handle)—NG- and RG-Frame**

	Description	Rating Type		NG-Frame	RG-Frame
		NEMA	IP	Catalog Number	Catalog Number
<b>S3 Blue Handle</b> 	S3 blue handle, 10-inch shaft	1/3R/12	54	<b>NGHMVD08B / 68C6043G01</b>	—
		4/4X	65	<b>NGHMVD08BX / 68C6043G03</b>	—
<b>S3 Red Handle</b> 	S3 red handle, 10-inch shaft	1/3R/12	54	<b>NGHMVD08R / 68C6043G02</b>	—
		4/4X	65	<b>NGHMVD08RX / 68C6043G04</b>	—
<b>S4 Blue Handle</b> 	S4 blue handle, 10-inch shaft	1/3R/12	54	<b>NGHMVD08BT / 68C6043G05</b>	<b>RGHMVD08B / 68C6044G01</b>
		4/4X	65	<b>NGHMVD08BTX / 68C6043G07</b>	<b>RGHMVD08BX / 68C6044G03</b>
<b>S4 Red Handle</b> 	S4 red handle, 10-inch shaft	1/3R/12	54	<b>NGHMVD08RT / 68C6043G06</b>	<b>RGHMVD08R / 68C6044G02</b>
		4/4X	65	<b>NGHMVD08RTX / 68C6043G08</b>	<b>RGHMVD08RX / 68C6044G04</b>

**Note**

Shaft guide (68C6048G49) is optional and can be used with any high-performance handle listed above for greater alignment tolerance.

**Separate Components for Series G Frames**

2

**Series G Components—Shafts and Mechanisms**

Frame	Shaft Width	Shaft Length				Mechanism Only
		6-Inch	10-Inch	12-Inch	24-Inch <sup>①</sup>	
EG	8 mm	66A6010G95	—	66A6010G96	66A6010G97	1498D66G17
JG	8 mm	66A6010G95	—	66A6010G96	66A6010G98	69D6025G17
LG	8 mm	66A6010G95	—	66A6010G96	66A6010G99	69D6051G30
NG	12 mm	—	66A6013H01	—	—	69D9101G30
RG	12 mm	—	66A6013H01	—	—	69D9101G31

**Series G Components—Handles Only**

Frame	Rating Type		Handles Only							
	NEMA	IP	S01 Blue/Black	S01 Red/Yellow	S2 Blue/Black	S2 Red/Yellow	S3 Blue/Black	S3 Red/Yellow	S4 Blue/Black	S4 Red/Yellow
EG	1/3R/12	54	68C6048G41	68C6048G42	68C6048G01	68C6048G02	—	—	—	—
	4/4X	65	68C6048G43	68C6048G44	68C6048G03	68C6048G04	—	—	—	—
JG	1/3R/12	54	68C6048G41	68C6048G42	68C6048G01	68C6048G02	—	—	—	—
	4/4X	65	68C6048G43	68C6048G44	68C6048G03	68C6048G04	—	—	—	—
LG	1/3R/12	54	—	—	68C6048G01	68C6048G02	68C6048G05	68C6048G06	—	—
	4/4X	65	—	—	68C6048G03	68C6048G04	68C6048G07	68C6048G08	—	—
NG	1/3R/12	54	—	—	—	—	68C6048G05	68C6048G06	68C6048G09	68C6048G10
	4/4X	65	—	—	—	—	68C6048G07	68C6048G08	68C6048G11	68C6048G12
RG	1/3R/12	54	—	—	—	—	—	—	68C6048G09	68C6048G10
	4/4X	65	—	—	—	—	—	—	68C6048G11	68C6048G12

**Series G Components—Optional Caps**

As an alternative to blue or red, a black, replaceable cap is available.

			Catalog Number
S01	66A6032H01	Black handle cap	HPHC0DGX
S2	66A6032H02	Black handle cap	HPHC2DGX
S3	66A6032H03	Black handle cap	HPHC3DGX

**Series G Replacement Hardware**

This kit provides replacement parts for Series G high performance handle only.

	Catalog Number
High-performance handle replacement parts kit	66A6029G01

**Notes**

① 24-inch handle comes with support bracket.

Shaft guide (68C6048G49) is optional and can be used with any high-performance handle listed above for greater alignment tolerance.

**Dimensions**

Approximate Dimensions in mm (Inches)

**High-Performance Rotary Handle Mechanisms**

Handle Type	Front Operation Direction of Operation	Door Drilling
Type S01		
Type S2		
Type S3		
Type S4		

Handle Mechanisms



### Contents

<i>Description</i>	<i>Page</i>
Handle Mechanisms—Series G . . . . .	<b>V4-T2-420</b>
High-Performance Rotary Handle Mechanisms..	<b>V4-T2-421</b>
Universal Rotary	
Product Selection. . . . .	<b>V4-T2-427</b>
Direct (Close-Coupled) Handle Mechanisms . . . .	<b>V4-T2-428</b>
Flex Shaft. . . . .	<b>V4-T2-429</b>
Handle Mechanisms—Series C	
High-Performance Rotary Handle Mechanisms..	<b>V4-T2-434</b>
Series C Rotary . . . . .	<b>V4-T2-438</b>
Universal Rotary . . . . .	<b>V4-T2-440</b>
Direct (Close-Coupled) Handle Mechanisms . . . .	<b>V4-T2-442</b>
Flex Shaft. . . . .	<b>V4-T2-444</b>
Handle Extension . . . . .	<b>V4-T2-447</b>

### Universal Rotary

#### Product Description

Eaton’s Universal Rotary is suitable for use with Type 1 or 12 enclosure types. All rotary handle mechanisms include a handle “lock off” to prevent turning the breaker ON while in the OFF position, and indicate ON/OFF/Tripped/Reset positions. The Universal Rotary has the added feature of international markings for ON (I) and OFF (O). The Universal Rotary is made of molded material.

The Universal Rotary mechanisms for EG-, JG- and LG-Frame MCCBs can be operated by hand with the door open or “locked off” to prevent operation with the door open.

#### Standards and Certifications

Universal Rotary is UL listed and meets CSA requirements. Universal Rotary also meets IEC 60947-1 and IEC 60947-2 for international compliance. Rotary UL File Number is E64983.



### Features

#### Features Comparison of Series C Rotary and Universal Rotary Handle Mechanism

Rotary	Number of Poles	NEMA Enclosure Type				Handle Lock-Off ②	Handle Indication: ON/OFF TRIPPED/RESET	International Markings ON (I) OFF (O)	Handle Material	Available Handle Colors	Handle Rotation	Shaft Lengths (Inches)
		1	3R	12	4/4X ①							
Series C rotary	—	■	■	■	■	■	■	■	Metal	Black	45 deg.	6, 12, 16, 24
Universal rotary	—	■	—	■	—	■	■	■	Molded plastic	Yellow/Red/Black	90 deg.	6, 12, 24

**Notes**

- ① Type 4/4X application requires special handle. See “Ordering Information.”
- ② All rotary handle mechanisms include a handle “Lock Off” to prevent turning the breaker ON while in the OFF position.

## Product Selection

## Universal Rotary



## Universal Rotary Through-the-Door Handle Mechanisms

Handle Color	UL Rating	Shaft Length in Inches (mm)	Complete Catalog Number <sup>①</sup>
<b>EG-Frame</b>			
Black	1, 12	6.00 (152.4)	<b>EHMVD06B</b>
		12.00 (304.8)	<b>EHMVD12B</b>
		24.00 (609.6)	<b>EHMVD24B</b>
Red	1, 12	6.00 (152.4)	<b>EHMVD06R</b>
		12.00 (304.8)	<b>EHMVD12R</b>
		24.00 (609.6)	<b>EHMVD24R</b>
<b>JG-Frame</b>			
Black	1, 12	6.00 (152.4)	<b>FJHMVD06B</b>
		12.00 (304.8)	<b>FJHMVD12B</b>
		24.00 (609.6)	<b>FJHMVD24B</b>
Red	1, 12	6.00 (152.4)	<b>FJHMVD06R</b>
		12.00 (304.8)	<b>FJHMVD12R</b>
		24.00 (609.6)	<b>FJHMVD24R</b>
<b>LG-Frame</b>			
Black	1, 12	6.00 (152.4)	<b>KLHMVD06B</b>
		12.00 (304.8)	<b>KLHMVD12B</b>
		24.00 (609.6)	<b>KLHMVD24B</b>
Red	1, 12	6.00 (152.4)	<b>KLHMVD06R</b>
		12.00 (304.8)	<b>KLHMVD12R</b>
		24.00 (609.6)	<b>KLHMVD24R</b>
<b>NG-Frame</b>			
Black	1	6.00 (152.4)	<b>HMVD5B</b>
<b>RG-Frame</b>			
Black	1	9.00 (228.6)	<b>HMVD6B</b>

## Series G Rotary



## Series G Rotary Ordering Information

Shaft Length Inches (mm)	Complete Catalog Number <sup>②</sup>	Separate Catalog Number		Shaft <sup>⑤</sup>	Catalog Number	
		Standard Handle <sup>③</sup>	Breaker Mechanism <sup>④</sup>		IEC IP65 <sup>⑥⑦</sup>	IEC IP66 <sup>⑥⑦</sup>
<b>N-Frame (ND and NG)</b>						
6.00 (152.4)	<b>HM5R06</b>	<b>6648C22G21</b>	<b>6648C23G08</b>	<b>4217B37G08</b>	<b>WHM5R06</b>	<b>WHM5R06X</b>
12.00 (304.8)	<b>HM5R12</b>	<b>6648C22G21</b>	<b>6648C23G08</b>	<b>4217B37G05</b>	<b>WHM5R12</b>	<b>WHM5R12X</b>
16.00 (406.4)	<b>HM5R16</b>	<b>6648C22G21</b>	<b>6648C23G08</b>	<b>4217B37G06</b>	<b>WHM5R16</b>	<b>WHM5R16X</b>
24.00 (609.6)	<b>HM5R24</b>	<b>6648C22G21</b>	<b>6648C23G08</b>	<b>4217B37G07</b>	<b>WHM5R24</b>	<b>WHM5R24X</b>

## Notes

- ① Complete catalog number includes handle, mechanism, shaft and mounting hardware.
- ② Complete catalog number includes the standard handle, mechanism, shaft and support brace/bracket.
- ③ Handle is designed suitable for NEMA Types 1, 3R and 12 enclosures. Use style number **6648C22G03** for Type 4/4X handle or add **X** Suffix to complete catalog number. Handle is cast aluminum.
- ④ Breaker mechanism includes a shaft support bracket and its parts. Shaft is .50-inch (12.7 mm).
- ⑤ Longer shafts, 16-inch (406.4 mm) and 24-inch (609.6 mm), include an adjustable support extension.
- ⑥ IEC handle mechanism supplied with metric thread mounting hardware.
- ⑦ Complete catalog number includes a handle, mechanism and shaft.

#### Handle Mechanisms

2



#### Contents

<i>Description</i>	<i>Page</i>
Handle Mechanisms—Series G .....	<b>V4-T2-420</b>
High-Performance Rotary Handle Mechanisms..	<b>V4-T2-421</b>
Universal Rotary .....	<b>V4-T2-426</b>
Direct (Close-Coupled) Handle Mechanisms	
Flex Shaft. ....	<b>V4-T2-429</b>
Handle Mechanisms—Series C	
High-Performance Rotary Handle Mechanisms..	<b>V4-T2-434</b>
Series C Rotary .....	<b>V4-T2-438</b>
Universal Rotary .....	<b>V4-T2-440</b>
Direct (Close-Coupled) Handle Mechanisms. . . .	<b>V4-T2-442</b>
Flex Shaft. ....	<b>V4-T2-444</b>
Handle Extension .....	<b>V4-T2-447</b>

### Direct (Close-Coupled) Handle Mechanisms

#### Product Description

Direct (close-coupled) handle mechanisms mount directly to the circuit breaker. They are used in shallow enclosures where the standard variable depth Through-the-door type mechanism is not practical or cannot be used.

The Universal Direct handle mechanisms are rated Type 1 and Type 12.

The Universal Direct handle mechanism is available as standard with a door interlock to prevent opening the enclosure while the circuit breaker is in the ON position. It is also available without a door interlock.

#### Application Description

Direct (close-coupled) handle mechanisms are typically used for applications where high volume, standardized enclosures are being fabricated.

#### Standards and Certifications

The Universal Direct handle mechanism is UL listed, IEC 60947-1 and IEC 60947-2 compliant, and meets CSA requirements.



#### Product Selection

Universal Direct  
(EG-LG)



#### Universal Direct Handle Mechanisms

Frame	Black Handle Color		Red Handle Color	
	With Interlock Catalog Number	Without Interlock Catalog Number	With Interlock Catalog Number	Without Interlock Catalog Number
EG	<b>EHMCCBI</b>	<b>EHMCCB</b>	<b>EHMCCRI</b>	<b>EHMCCR</b>
JG	<b>JHMCCBI</b>	<b>JHMCCB</b>	<b>JHMCCRI</b>	<b>JHMCCR</b>
LG	<b>LHMCCBI</b>	<b>LHMCCB</b>	<b>LHMCCRI</b>	<b>LHMCCR</b>

## Handle Mechanisms



## Flex Shaft

## Product Description

**Flange-Mounted Handle Mechanisms**

Flange-mounted handle mechanisms mount on the flange of an enclosure door. The Flex Shaft is an extra heavy-duty mechanism that includes a flexible shaft in various lengths, 3 feet (0.9m) through 10 feet (3m) for use with various size enclosures.

The Flex Shaft handle will accept up to three padlock shackles, each with a maximum diameter of 3/8 inches (9.5 mm). It can be used with Type 12 fabricated enclosures. An optional handle is available for Flex Shaft that is suitable for use with Type 4 environments.

Flex Shaft comes preset from the factory, requiring only minor field adjustments on installation, which takes about 10 minutes—a significant time savings compared to installation of other types of flange handle mechanisms. The Flex Shaft mechanism also takes up less interior enclosure space than competitive designs, and the handle fits standard flange cutouts. Flex Shaft handle can be remotely mounted from breaker, where an operator can use it by “funneling” the cable through conduit.

## Contents

**Description**

	<b>Page</b>
Handle Mechanisms—Series G . . . . .	<b>V4-T2-420</b>
High-Performance Rotary Handle Mechanisms . . . . .	<b>V4-T2-421</b>
Universal Rotary . . . . .	<b>V4-T2-426</b>
Direct (Close-Coupled) Handle Mechanisms . . . . .	<b>V4-T2-428</b>
Flex Shaft . . . . .	
Product Selection . . . . .	<b>V4-T2-430</b>
Accessories . . . . .	<b>V4-T2-431</b>
Dimensions . . . . .	<b>V4-T2-431</b>
Handle Mechanisms—Series C . . . . .	
High-Performance Rotary Handle Mechanisms . . . . .	<b>V4-T2-434</b>
Series C Rotary . . . . .	<b>V4-T2-438</b>
Universal Rotary . . . . .	<b>V4-T2-440</b>
Direct (Close-Coupled) Handle Mechanisms . . . . .	<b>V4-T2-442</b>
Flex Shaft . . . . .	<b>V4-T2-444</b>
Handle Extension . . . . .	<b>V4-T2-447</b>

## Standards and Certifications

Flex Shaft is UL listed under File E64983 and meets CSA requirements.



#### Product Selection

**Note:** Type 4X handle mechanisms are available. Add Suffix X to the complete Catalog Number.

**Note:** When selecting the length of shaft, ensure minimum bending radius of 4 inches (101.6 mm) is maintained to operate properly.

**Note:** The standard method of shipment includes the mechanism preset at the factory; however, minor field adjustments may be required.

#### Flex Shaft



#### Flex Shaft Flange-Mounted Handle Mechanisms ①②

Breaker Frame	Flexible Shaft Length in Feet (m)				
	2 (0.6) Catalog Number	3 (0.9) Catalog Number	4 (1.2) Catalog Number	5 (1.3) Catalog Number	6 (1.8) Catalog Number
EG	EHMFS02	EHMFS03	EHMFS04	EHMFS05	EHMFS06
JG	N/A	JHMFS03	JHMFS04	JHMFS05	JHMFS06
LG	N/A	—	LHMFS04	—	—
NG	N/A	N/A	F5S04C	F5S05C	F5S06C
RG	N/A	N/A	F6S04	F6S05	F6S06

Breaker Frame	Flexible Shaft Length in Feet (m)			
	7 (2.1) Catalog Number	8 (2.4) Catalog Number	9 (2.7) Catalog Number	10 (3.1) Catalog Number
EG	EHMFS07	EHMFS08	EHMFS09	EHMFS10
JG	JHMFS07	JHMFS08	JHMFS09	JHMFS10
LG	LHMFS07	—	—	LHMFS10
NG	N/A	N/A	N/A	F5S10C
RG	N/A	N/A	N/A	N/A

#### High-Performance Flex Shaft



#### High-Performance Flex Shaft Flange Mounted Handle Mechanism ①②

Breaker Frame	Flexible Shaft Length in Feet (m)				
	2 (0.6) Catalog Number	3 (0.9) Catalog Number	4 (1.2) Catalog Number	5 (1.3) Catalog Number	6 (1.8) Catalog Number
EG	EGFS02HP	EGFS03HP	EGFS04HP	EGFS05HP	EGFS06HP
JG	N/A	JGFS03HP	JGFS04HP	JGFS05HP	JGFS06HP
LG	N/A	N/A	LGFS04HP	N/A	N/A
NG	N/A	N/A	F5S04HP	F5S05HP	F5S06HP
RG	N/A	N/A	F6S04HP	F6S05HP	F6S06HP

Breaker Frame	Flexible Shaft Length in Feet (m)			
	7 (2.1) Catalog Number	8 (2.4) Catalog Number	9 (2.7) Catalog Number	10 (3.1) Catalog Number
EG	EGFS07HP	EGFS08HP	EGFS09HP	EGFS10HP
JG	JGFS07HP	JGFS08HP	JGFS09HP	JGFS10HP
LG	LGFS07HP	N/A	N/A	LGFS10HP
NG	N/A	N/A	N/A	F5S10HP
RG	N/A	N/A	N/A	N/A

#### Notes

- ① Three-pole only for EG-; three- and four-pole for JG- and LG-Frame.
- ② EG-, JG- and LG-Frame can be left- or right-hand mounted.

## Accessories

### Handle Auxiliary Switch—Early Break Design, 1A–1B Contact for Flex Shaft

Breaker Frame	Catalog Number
EG	AUX1EBFSEG
JG	AUX1EBFSJG
LG	AUX1EBFSLG

Auxiliary contact changes state prior to parting of breaker contacts to allow for shutdown of equipment. Contacts mounted on breaker mechanism customer supplied wiring.

### Type 12 Safety Door Hardware for Flex Shaft (E- through R-Frame) <sup>①</sup>

Catalog Number <sup>②</sup>
C361KJ4
C361KJ6
C361KR

## Dimensions

### Type 12 Safety Door Hardware for Flex Shaft (E- through R-Frame) <sup>①</sup>

Catalog Number <sup>②</sup>	Handle Length in Inches (mm)
C361KJ4	4.00 (101.6)
C361KJ6	6.00 (152.4)
C361KR	Roller latch <sup>③</sup>

#### Notes

- ① Customer: Consult with box manufacturer for correct door hardware and any adapters required for assembly.
- ② The 1/4-inch x 1/2-inch (6.35 x 12.7 mm) standard mill rectangular locking bar is not supplied with these kits.
- ③ Third roller latch for use with 4.00- or 6.00-inch (101.6 or 152.4 mm) handle when three-point latching is required.

#### Handle Mechanisms

2



#### Contents

##### Description

##### Page

Handle Mechanisms—Series G . . . . .	<b>V4-T2-420</b>
High-Performance Rotary Handle Mechanisms..	<b>V4-T2-421</b>
Universal Rotary . . . . .	<b>V4-T2-426</b>
Direct (Close-Coupled) Handle Mechanisms . . . .	<b>V4-T2-428</b>
Flex Shaft. . . . .	<b>V4-T2-429</b>
Handle Mechanisms—Series C	
High-Performance Rotary Handle Mechanisms..	<b>V4-T2-434</b>
Series C Rotary . . . . .	<b>V4-T2-438</b>
Universal Rotary . . . . .	<b>V4-T2-440</b>
Direct (Close-Coupled) Handle Mechanisms . . . .	<b>V4-T2-442</b>
Flex Shaft. . . . .	<b>V4-T2-444</b>
Handle Extension . . . . .	<b>V4-T2-447</b>

### Handle Mechanisms—Series C

#### Product Overview

Handle mechanisms are used to operate molded case circuit breakers, molded case switches and motor circuit protectors. They are available in three basic configurations—Flange Mounted, Through-the-Door and Direct (Close-Coupled)—providing safe, dependable operation and ease of installation.

#### Through-the-Door

- High-Performance Rotary
- Series C Rotary
- Universal Rotary

#### Direct (Close-Coupled)

- Universal Direct
- Euro IEC
- G Direct

#### Flange Mounted

- Flex Shaft
- C371

Handle mechanisms are used on enclosed circuit breakers, control panels and motor control centers in many different applications. Eaton has a handle mechanism for virtually any need.

**Through-the-Door Handle Mechanisms**

Eaton's through-the-door handle mechanisms mount on the front of an enclosure or cabinet door and externally operate the circuit breaker via a variable depth shaft or a linear operator (Type MC). Each rotary type handle mechanism includes a handle, base operating mechanism and shaft that can be cut to various lengths.

Series C Rotary and Universal Rotary handle mechanisms are for use with molded case circuit breakers (G, F, J, K, L, MDL), molded case switches and motor circuit protectors.

Type 4/4X handles are similar to standard handles except they include an internal neoprene gasket. Type 4/4X handle style number is 6648C22G03. Due to gasketing effect between the handle and the housing, the handle may not indicate a tripped position.

**Universal Rotary F-Frame****Direct (Close-Coupled) Handle Mechanisms**

Direct (close-coupled) handle mechanisms mount directly to the circuit breaker. They are used in shallow enclosures where the standard variable depth Through-the-door type mechanism is not practical or cannot be used. They are typically for applications where high volume, standardized enclosures are being fabricated.

The Euro IEC Direct handle mechanism can be used on F- through R-Frames.

The G Direct is available with a black or the yellow handle, and with or without a shroud. It is suitable for use with NEMA 1 enclosures. It is for use only with the G-Frame (GD, GC, GHC, GMCP).

An escutcheon ring and interlock clip are provided as standard. The standard design includes a lock-off feature.

**Flange-Mounted Handle Mechanisms**

Flange-mounted handle mechanisms mount on the flange of an enclosure door. The Flex Shaft is an extra heavy-duty mechanism that includes a flexible shaft in various lengths, 3 feet (0.9m) through 10 feet (3m) for use with various size enclosures.

The Flex Shaft handle will accept up to three padlock shackles, each with a maximum diameter of 3/8-inch (9.5 mm). Can be used with NEMA 1, 3R and 12 fabricated enclosures. An optional handle is available for Flex Shaft that is suitable for use with NEMA 4 and 4X environments. Flex Shaft comes preset from the factory, requiring only minor field adjustments on installation, which takes about 10 minutes—a significant time savings compared to installation of other types of flange handle mechanisms. The Flex Shaft mechanism also takes up less interior enclosure space than competitive designs and the handle fits standard flange cutouts. Flex Shaft handle can be remotely mounted from breaker, where an operator can use it by “funneling” the cable through conduit.

The Type C371 circuit breaker operating mechanisms are designed for installation in control enclosures where main or branch circuit protective devices are required. All circuit breaker mechanisms are suitable for right-hand mounting.

Auxiliary contacts are not available for mounting on operating mechanisms. Where required, have them installed in circuit breaker.

**Handle Extension**

Handle extension is not included with J, K, L, M and N-Frame breakers. It must be purchased separately.

**Standards and Certifications**

Type C371 is UL Listed under File E62635.

Flex Shaft is UL Listed under File E64983 and meets CSA requirements.

Series C Rotary and Universal Rotary, are UL Listed and meet CSA requirements. Universal Rotary also meets IEC 60947-1 and IEC 60947-2 for international compliance. Rotary UL File Number is E64983.

The Universal Direct handle mechanism is UL 489 Listed, IEC 60947-1 and IEC 60947-2, and meets CSA requirements. The Euro IEC Direct handle mechanism is IEC-240-1. G Direct is UL Listed and meets CSA requirements.



#### Handle Mechanisms

2



#### Description

	<i>Page</i>
Handle Mechanisms—Series G . . . . .	<b>V4-T2-420</b>
High-Performance Rotary Handle Mechanisms . . . . .	<b>V4-T2-421</b>
Universal Rotary . . . . .	<b>V4-T2-426</b>
Direct (Close-Coupled) Handle Mechanisms . . . . .	<b>V4-T2-428</b>
Flex Shaft. . . . .	<b>V4-T2-429</b>
Handle Mechanisms—Series C . . . . .	
High-Performance Rotary Handle Mechanisms . . . . .	<b>V4-T2-434</b>
Product Selection. . . . .	<b>V4-T2-435</b>
Dimensions . . . . .	<b>V4-T2-437</b>
Series C Rotary . . . . .	<b>V4-T2-438</b>
Universal Rotary . . . . .	<b>V4-T2-440</b>
Direct (Close-Coupled) Handle Mechanisms . . . . .	<b>V4-T2-442</b>
Flex Shaft. . . . .	<b>V4-T2-444</b>
Handle Extension . . . . .	<b>V4-T2-447</b>

### High-Performance Rotary Handle Mechanisms

#### Product Description

The high-performance rotary handle mechanism uses a simple, yet robust design to make installation and operation easy. The external handle's key functional components are all metallic, ensuring reliability. The metal-on-metal interface between the handle and shaft prevents contaminant buildup that could impede operation, while UV and chemical agent resistant materials protect the handle from heat and fading in direct sunlight, as well as chemicals that may be introduced in harsh environments.

In addition to its robust design features, the handle mechanism has stand-off support that allows for easy operation with a gloved hand. With a shallow profile, the handle can easily be used in applications where an internal or double door is required.

The high-performance external handle can accept padlocks or multi-hasps locks. The door is interlocked when padlocked and cannot be bypassed.

#### Features

- NEMA Type 1/3R/12 (IP54) and NEMA Type 4/4X (IP65) ratings
- Black/Blue or Red/Yellow external handle colors
- Three shaft lengths—6, 12 and 24 inches, which can be cut to size to match enclosure depth
- Conveniently packaged as kit containing handle, shaft and mechanism
- Replacement parts are available separately
- Metallic functional components ensure reliability
- Metal-on-metal interface between handle and shaft
- UV and chemical agent-resistant materials protect the handle
- Shallow profile
- Compatible with both Series C and Series G molded case circuit breakers and molded case switch platforms
- Same handle can be used on multiple frames sizes reducing the number of parts needed
- Red and yellow handles to designate emergency disconnecting means
- All handle mechanisms can accept padlocks or multi-hasps locks for added flexibility
- Fast, easy installation (see video on website for step-by-step instructions)

#### Standards and Certifications

The mechanisms for EG, JG and LG breakers have an internal handle that can be operated independent of door position, and locked-out to meet one of the key NFPA requirements (NFPA® 79) and UL 508A disconnect requirements.



- NEMA 1/3R/12, IP54
- NEMA 4/4X, IP65



## Product Selection

### Handle Mechanisms for Series C Frames

#### Kits Only (Kit Includes Shaft, Mechanism and Handle)—GC/GD- and GMCP-Frame

	Description	Rating Type		GC/GD-Frame	GMCP-Frame
		NEMA	IP	Catalog Number	Catalog Number
<b>S01 Blue Handle</b> 	S01 blue handle, 12-inch shaft	1/3R/12	54	<b>GCHMVD12B / 68C6039G01</b>	<b>GMHMVD12B / 68C6039G05</b>
		4/4X	65	<b>GCHMVD12BX / 68C6039G03</b>	<b>GMHMVD12BX / 68C6039G07</b>
<b>S01 Red Handle</b> 	S01 red handle, 12-inch shaft	1/3R/12	54	<b>GCHMVD12R / 68C6039G02</b>	<b>GMHMVD12R / 68C6039G06</b>
		4/4X	65	<b>GCHMVD12RX / 68C6039G04</b>	<b>GMHMVD12RX / 68C6039G08</b>

### Separate Components for Series C Frames

#### Series C Components—Shaft and Mechanism

Frame	Shaft Width	Shaft Length			Mechanism Only
		6-Inch	10-Inch	12-Inch	
GC/GD	6 mm	—	—	<b>66A6013H02</b>	<b>GCHMVD / 2A92095G15</b>
GMCP	6 mm	—	—	<b>66A6013H02</b>	<b>GMHMVD / 2A92095G16</b>
GD	8 mm	<b>66A6010G95</b>	—	<b>66A6010G96</b>	<b>1498D34G90</b>
FD	8 mm	<b>66A6010G95</b>	—	<b>66A6010G96</b>	<b>1498D34G91</b>
JD	10 mm	<b>66A6012G15</b>	—	<b>66A6012G16</b>	<b>1498D34G92</b>
KD	10 mm	<b>66A6012G15</b>	—	<b>66A6012G16</b>	<b>1498D34G93</b>
LD	10 mm	<b>66A6012G15</b>	—	<b>66A6012G16</b>	<b>1498D34G94</b>
MDL	10 mm	<b>66A6012G15</b>	—	<b>66A6012G16</b>	<b>1498D34G95</b>
ND	12 mm	—	<b>66A6013H01</b>	—	<b>69D9101G30</b>
RD	12 mm	—	<b>66A6013H01</b>	—	<b>69D9101G31</b>

#### Note

Shaft guide (68C6048G49) is optional and can be used with any high-performance handle listed above for greater alignment tolerance.

## Series C Components—Handles Only

Frame	Rating Type		Handles Only							
	NEMA	IP	S01 Blue/Black	S01 Red/Yellow	S2 Blue/Black	S2 Red/Yellow	S3 Blue/Black	S3 Red/Yellow	S4 Blue/Black	S4 Red/Yellow
GC/GD	1/3R/12	54	68C6048G41	68C6048G42	—	—	—	—	—	—
	4/4X	65	68C6048G43	68C6048G44	—	—	—	—	—	—
GMCP	1/3R/12	54	68C6048G41	68C6048G42	—	—	—	—	—	—
	4/4X	65	68C6048G43	68C6048G44	—	—	—	—	—	—
GD	1/3R/12	54	68C6048G41	68C6048G42	68C6048G01	68C6048G02	—	—	—	—
	4/4X	65	68C6048G43	68C6048G44	68C6048G03	68C6048G04	—	—	—	—
FD	1/3R/12	54	68C6048G41	68C6048G42	68C6048G01	68C6048G02	—	—	—	—
	4/4X	65	68C6048G43	68C6048G44	68C6048G03	68C6048G04	—	—	—	—
JD	1/3R/12	54	—	—	68C6048G01	68C6048G02	—	—	—	—
	4/4X	65	—	—	68C6048G03	68C6048G04	—	—	—	—
KD	1/3R/12	54	—	—	68C6048G01	68C6048G02	—	—	—	—
	4/4X	65	—	—	68C6048G03	68C6048G04	—	—	—	—
LD	1/3R/12	54	—	—	68C6048G01	68C6048G02	68C6048G05	68C6048G06	—	—
	4/4X	65	—	—	68C6048G03	68C6048G04	68C6048G07	68C6048G08	—	—
MDL	1/3R/12	54	—	—	68C6048G01	68C6048G02	68C6048G05	68C6048G06	—	—
	4/4X	65	—	—	68C6048G03	68C6048G04	68C6048G07	68C6048G08	—	—
ND	1/3R/12	54	—	—	—	—	68C6048G05	68C6048G06	68C6048G09	68C6048G10
	4/4X	65	—	—	—	—	68C6048G07	68C6048G08	68C6048G11	68C6048G12
RD	1/3R/12	54	—	—	—	—	—	—	68C6048G09	68C6048G10
	4/4X	65	—	—	—	—	—	—	68C6048G11	68C6048G12

**Note**

Shaft guide (68C6048G49) is optional and can be used with any high-performance handle listed above for greater alignment tolerance.

**Dimensions**

Approximate Dimensions in mm (Inches)

**High-Performance Rotary Handle Mechanisms**

Handle Type	Front Operation Direction of Operation	Door Drilling
Type S01		
Type S2		
Type S3		
Type S4		

#### Handle Mechanisms

2



#### Contents

<i>Description</i>	<i>Page</i>
Handle Mechanisms—Series G . . . . .	<b>V4-T2-420</b>
High-Performance Rotary Handle Mechanisms..	<b>V4-T2-421</b>
Universal Rotary	
Direct (Close-Coupled) Handle Mechanisms . . . .	<b>V4-T2-428</b>
Flex Shaft. . . . .	<b>V4-T2-429</b>
Handle Mechanisms—Series C	
High-Performance Rotary Handle Mechanisms..	<b>V4-T2-434</b>
Series C Rotary . . . . .	<b>V4-T2-438</b>
Product Selection. . . . .	<b>V4-T2-439</b>
Universal Rotary . . . . .	<b>V4-T2-440</b>
Direct (Close-Coupled) Handle Mechanisms . . . .	<b>V4-T2-442</b>
Flex Shaft. . . . .	<b>V4-T2-444</b>
Handle Extension . . . . .	<b>V4-T2-447</b>

### Series C Rotary

#### Product Description

Eaton’s through-the-door handle mechanisms mount on the front of an enclosure or a cabinet door and externally operate the circuit breaker via a variable depth shaft or a linear operator (Type MC). Each rotary type handle mechanism includes a handle, a base operating mechanism and a shaft that can be cut to various lengths.

Series C Rotary handle mechanisms are used with molded case circuit breakers (F, J, K, L, MDL), molded case switches and motor circuit protectors.

These rotary handles are robust and durable, made entirely of metal parts. It also has a lock-out tag-out level at the tip of the handle for padlocking.

NEMA Type 4/4X handles are similar to standard handles except they include an internal neoprene gasket. NEMA Type 4/4X handle style number is 6648C22G03. Due to gasketing effect between the handle and the housing, the handle may not indicate a tripped position.

#### Standards and Certifications

Series C Rotary is UL listed and meets CSA requirements.



#### Features

#### Features Comparison of Series C Rotary and Universal Rotary Handle Mechanism

Rotary	Number of Poles	NEMA Enclosure Type				Handle Lock-Off ②	Handle Indication: ON/OFF TRIPPED/RESET	International Markings ON (I) OFF (O)	Handle Material	Available Handle Colors	Handle Rotation	Shaft Lengths (Inches)
		1	3R	12	4/4X ①							
Series C rotary	—	■	■	■	■	■	■	■	Metal	Black	45 deg.	6, 12, 16, 24
Universal rotary	—	■	—	■	—	■	■	■	Molded plastic	Yellow/Red/Black	90 deg.	6, 12, 24

#### Notes

- ① Type 4/4X application requires special handle. See “Ordering Information.”
- ② All rotary handle mechanisms include a handle “Lock Off” to prevent turning the breaker ON while in the OFF position.

## Product Selection

## Through-the-Door Handle Mechanisms

## Series C Rotary

## Series C Rotary Ordering Information



Shaft Length Inches (mm)	Complete Catalog Number <sup>①</sup>	Separate Catalog Number		Shaft <sup>④</sup>	Catalog Number	
		Standard Handle <sup>②</sup>	Breaker Mechanism <sup>③</sup>		IEC IP65 <sup>⑤⑥</sup>	IEC IP66 <sup>⑤⑥</sup>
<b>F-Frame</b>						
6.00 (152.4)	HM1R06	6648C22G25	6648C23G11	4217B37G08	WHM1R06	WHM1R06X
12.00 (304.8)	HM1R12	6648C22G25	6648C23G11	4217B37G05	WHM1R12	WHM1R12X
16.00 (406.4)	HM1R16	6648C22G25	6648C23G11	4217B37G06	WHM1R16	WHM1R16X
24.00 (609.6)	HM1R24	6648C22G25	6648C23G11	4217B37G07	WHM1R24	WHM1R24X
<b>J-Frame</b>						
6.00 (152.4)	HM2R06	6648C22G01	6648C23G21	4217B37G08	WHM2R06	WHM2R06X
12.00 (304.8)	HM2R12	6648C22G01	6648C23G21	4217B37G05	WHM2R12	WHM2R12X
16.00 (406.4)	HM2R16	6648C22G01	6648C23G21	4217B37G06	WHM2R16	WHM2R16X
24.00 (609.6)	HM2R24	6648C22G01	6648C23G21	4217B37G07	WHM2R24	WHM2R24X
<b>K-Frame</b>						
6.00 (152.4)	HM3R06	6648C22G01	6648C23G25	4217B37G08	WHM3R06	WHM3R06X
12.00 (304.8)	HM3R12	6648C22G01	6648C23G25	4217B37G05	WHM3R12	WHM3R12X
16.00 (406.4)	HM3R16	6648C22G01	6648C23G25	4217B37G06	WHM3R16	WHM3R16X
24.00 (609.6)	HM3R24	6648C22G01	6648C23G25	4217B37G07	WHM3R24	WHM3R24X
<b>L- and MDL-Frame</b>						
6.00 (152.4)	HM4R06	6648C22G11	6648C23G19	4217B37G08	WHM4R06	WHM4R06X
12.00 (304.8)	HM4R12	6648C22G11	6648C23G19	4217B37G05	WHM4R12	WHM4R12X
16.00 (406.4)	HM4R16	6648C22G11	6648C23G19	4217B37G06	WHM4R16	WHM4R16X
24.00 (609.6)	HM4R24	6648C22G11	6648C23G19	4217B37G07	WHM4R24	WHM4R24X
<b>MD/MDS</b>						
6.00 (152.4)	HM7R06	6648C22G21	6648C23G17	4217B37G08	—	—
12.00 (304.8)	HM7R12	6648C22G21	6648C23G17	4217B37G05	—	—
16.00 (406.4)	HM7R16	6648C22G21	6648C23G17	4217B37G06	—	—
24.00 (609.6)	HM7R24	6648C22G21	6648C23G17	4217B37G07	—	—
<b>N-Frame (ND and NG)</b>						
6.00 (152.4)	HM5R06	6648C22G21	6648C23G08	4217B37G08	WHM5R06	WHM5R06X
12.00 (304.8)	HM5R12	6648C22G21	6648C23G08	4217B37G05	WHM5R12	WHM5R12X
16.00 (406.4)	HM5R16	6648C22G21	6648C23G08	4217B37G06	WHM5R16	WHM5R16X
24.00 (609.6)	HM5R24	6648C22G21	6648C23G08	4217B37G07	WHM5R24	WHM5R24X

**Notes**

- ① Complete catalog number includes the standard handle, mechanism, shaft and support brace/bracket.
- ② Handle is designed suitable for NEMA Types 1, 3R and 12 enclosures. Use style number **6648C22G03** for Type 4/4X handle or add **X** Suffix to complete catalog number. Handle is cast aluminum.
- ③ Breaker mechanism includes a shaft support bracket and its parts. Shaft is .50-inch (12.7 mm).
- ④ Longer shafts, 16-inch (406.4 mm) and 24-inch (609.6 mm), include an adjustable support extension.
- ⑤ IEC handle mechanism supplied with metric thread mounting hardware.
- ⑥ Complete catalog number includes a handle, mechanism and shaft.

#### Handle Mechanisms

2



#### Contents

<i>Description</i>	<i>Page</i>
Handle Mechanisms—Series G . . . . .	<b>V4-T2-420</b>
High-Performance Rotary Handle Mechanisms..	<b>V4-T2-421</b>
Universal Rotary	
Product Selection. . . . .	<b>V4-T2-427</b>
Direct (Close-Coupled) Handle Mechanisms . . . .	<b>V4-T2-428</b>
Flex Shaft. . . . .	<b>V4-T2-429</b>
Handle Mechanisms—Series C	
High-Performance Rotary Handle Mechanisms..	<b>V4-T2-434</b>
Series C Rotary . . . . .	<b>V4-T2-438</b>
Universal Rotary . . . . .	<b>V4-T2-440</b>
Product Selection. . . . .	<b>V4-T2-441</b>
Direct (Close-Coupled) Handle Mechanisms . . . .	<b>V4-T2-442</b>
Flex Shaft. . . . .	<b>V4-T2-444</b>
Handle Extension . . . . .	<b>V4-T2-447</b>

### Universal Rotary

#### Product Description

Eaton's Universal Rotary is suitable for use with Type 1 or 12 enclosure types. All rotary handle mechanisms include a handle "lock off" to prevent turning the breaker ON while in the OFF position, and indicate ON/OFF/Tripped/Reset positions. The Universal Rotary has the added feature of international markings for ON (I) and OFF (O). The Universal Rotary is made of molded material.

The Universal Rotary mechanisms for EG-, JG- and LG-Frame MCCBs can be operated by hand with the door open or "locked off" to prevent operation with the door open.

#### Standards and Certifications

Universal Rotary is UL listed and meets CSA requirements. Universal Rotary also meets IEC 60947-1 and IEC 60947-2 for international compliance. Rotary UL File Number is E64983.



### Features

#### Features Comparison of Series C Rotary and Universal Rotary Handle Mechanism

Rotary	Number of Poles	NEMA Enclosure Type				Handle Lock-Off ②	Handle Indication: ON/OFF TRIPPED/RESET	International Markings ON (I) OFF (O)	Handle Material	Available Handle Colors	Handle Rotation	Shaft Lengths (Inches)
		1	3R	12	4/4X ①							
Series C rotary	—	■	■	■	■	■	■	■	Metal	Black	45 deg.	6, 12, 16, 24
Universal rotary	—	■	—	■	—	■	■	■	Molded plastic	Yellow/Red/Black	90 deg.	6, 12, 24

#### Notes

- ① Type 4/4X application requires special handle. See "Ordering Information."
- ② All rotary handle mechanisms include a handle "Lock Off" to prevent turning the breaker ON while in the OFF position.

## Product Selection

## Universal Rotary F-Frame

Universal Rotary  
F-Frame

## Series C Universal Rotary ①

Handle Color	Shaft Length in Inches (mm)	Complete Catalog Number
<b>G-Frame</b>		
Black	6.00 (152.4)	<b>GHMVD06B</b>
	12.00 (304.8)	<b>GHMVD12B</b>
Red	6.00 (152.4)	<b>GHMVD06R</b>
	12.00 (304.8)	<b>GHMVD12R</b>
<b>F-Frame</b>		
Black	6.00 (152.4)	<b>FHMVD06B</b>
	12.00 (304.8)	<b>FHMVD12B</b>
Red	6.00 (152.4)	<b>FHMVD06R</b>
	12.00 (304.8)	<b>FHMVD12R</b>
	24.00 (609.6)	<b>FHMVD24R</b>
<b>J-Frame</b>		
Black	6.00 (152.4)	<b>JHMVD06B</b>
	12.00 (304.8)	<b>JHMVD12B</b>
Red	6.00 (152.4)	<b>JHMVD06R</b>
	12.00 (304.8)	<b>JHMVD12R</b>
<b>K-Frame</b>		
Black	6.00 (152.4)	<b>KHMVD06B</b>
	12.00 (304.8)	<b>KHMVD12B</b>
Red	6.00 (152.4)	<b>KHMVD06R</b>
	12.00 (304.8)	<b>KHMVD12R</b>
<b>L-Frame</b>		
Black	6.00 (152.4)	<b>LHMVD06B</b>
	12.00 (304.8)	<b>LHMVD12B</b>
Red	6.00 (152.4)	<b>LHMVD06R</b>
	12.00 (304.8)	<b>LHMVD12R</b>

**Note**

① Only available as complete handle mechanism. Parts not sold separately.

#### Handle Mechanisms

2



#### Contents

<i>Description</i>	<i>Page</i>
Handle Mechanisms—Series G .....	<b>V4-T2-420</b>
High-Performance Rotary Handle Mechanisms..	<b>V4-T2-421</b>
Universal Rotary .....	<b>V4-T2-426</b>
Direct (Close-Coupled) Handle Mechanisms	
Flex Shaft. ....	<b>V4-T2-429</b>
Handle Mechanisms—Series C	
High-Performance Rotary Handle Mechanisms..	<b>V4-T2-434</b>
Series C Rotary .....	<b>V4-T2-438</b>
Direct (Close-Coupled) Handle Mechanisms . . .	<b>V4-T2-442</b>
Product Selection. ....	<b>V4-T2-443</b>
Flex Shaft. ....	<b>V4-T2-444</b>
Handle Extension .....	<b>V4-T2-447</b>

### Direct (Close-Coupled) Handle Mechanisms

#### Product Description

Direct (close-coupled) handle mechanisms mount directly to the circuit breaker. They are used in shallow enclosures where the standard variable depth Through-the-door type mechanism is not practical or cannot be used.

The Universal Direct handle mechanisms are rated Type 1 and Type 12.

The Universal Direct handle mechanism is available as standard with a door interlock to prevent opening the enclosure while the circuit breaker is in the ON position. It is also available without a door interlock.

#### Application Description

Direct (close-coupled) handle mechanisms are typically used for applications where high volume, standardized enclosures are being fabricated.

#### Standards and Certifications

The Universal Direct handle mechanism is IEC 60947-1 and IEC 60947-2 compliant.

**Product Selection****Direct (Close-Coupled) Handle Mechanisms****Euro IEC Direct**

Frame	Black Handle Catalog Number
F	HMCC1B
J	HMCC2B
K	HMCC3B
L and M	HMCC4B
N	HMVD5B
R	HMVD6B

**G Direct** <sup>①</sup>

Frame	Black Handle		Yellow Handle	
	With Shroud Catalog Number	Without Shroud Catalog Number	With Shroud Catalog Number	Without Shroud Catalog Number
GD/GHC	HRGCC1S	HRGCC10	HRGCC3S	HRGCC30
GMCP	HRGMC1S	HRGMC10	HRGMC3S	HRGMC30

**Note**

<sup>①</sup> Suitable for use on two- or three-pole G-Frame.

#### Handle Mechanisms

2

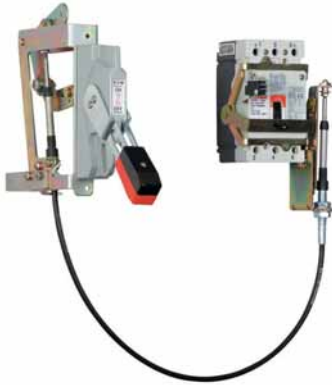

### Flex Shaft

#### Product Description

##### **Flange-Mounted Handle Mechanisms**

Flange-mounted handle mechanisms mount on the flange of an enclosure door. The Flex Shaft is an extra heavy-duty mechanism that includes a flexible shaft in various lengths, 3 feet (0.9m) through 10 feet (3m) for use with various size enclosures.

The Flex Shaft handle will accept up to three padlock shackles, each with a maximum diameter of 3/8 inches (9.5 mm). It can be used with Type 12 fabricated enclosures. An optional handle is available for Flex Shaft that is suitable for use with Type 4 environments.

Flex Shaft comes preset from the factory, requiring only minor field adjustments on installation, which takes about 10 minutes—a significant time savings compared to installation of other types of flange handle mechanisms. The Flex Shaft mechanism also takes up less interior enclosure space than competitive designs, and the handle fits standard flange cutouts. Flex Shaft handle can be remotely mounted from breaker, where an operator can use it by “funneling” the cable through conduit.

### Contents

#### **Description**

	<b>Page</b>
Handle Mechanisms—Series G . . . . .	<b>V4-T2-420</b>
High-Performance Rotary Handle Mechanisms . . . . .	<b>V4-T2-421</b>
Universal Rotary . . . . .	<b>V4-T2-426</b>
Direct (Close-Coupled) Handle Mechanisms . . . . .	<b>V4-T2-428</b>
Flex Shaft . . . . .	
Handle Mechanisms—Series C . . . . .	
High-Performance Rotary Handle Mechanisms . . . . .	<b>V4-T2-434</b>
Series C Rotary . . . . .	<b>V4-T2-438</b>
Direct (Close-Coupled) Handle Mechanisms . . . . .	<b>V4-T2-442</b>
Flex Shaft . . . . .	<b>V4-T2-444</b>
Product Selection . . . . .	<b>V4-T2-445</b>
Handle Extension . . . . .	<b>V4-T2-447</b>

#### Standards and Certifications

Flex Shaft is UL listed under File E64983 and meets CSA requirements.



## Product Selection

### Handle Mechanisms

#### Flex Shaft <sup>①②</sup>

Breaker Frame	Flexible Shaft Length in Feet (m)							
	3 (0.9)	4 (1.2)	5 (1.5)	6 (1.8)	7 (2.1)	8 (2.4)	9 (2.7)	10 (3.0)
	Catalog Number	Catalog Number	Catalog Number	Catalog Number	Catalog Number	Catalog Number	Catalog Number	Catalog Number
G <sup>①</sup>	F0S03C	F0S04C	F0S05C	F0S06C	—	—	—	—
F	F1S03C	F1S04C	F1S05C	F1S06C	F1S07C	F1S08C	F1S09C	F1S10C
F (dual)	F1S03CD	F1S04CD	F1S05CD	F1S06CD	F1S07CD	F1S08CD	F1S09CD	F1S10CD
J	F2S03C	F2S04C	F2S05C	F2S06C	F2S07C	F2S08C	F2S09C	F2S10C
K	F3S03C	F3S04C	F3S05C	F3S06C	F3S07C	F3S08C	F3S09C	F3S10C
L and MDL	—	F4S04C	F4S05C	F4S06C	—	—	—	F4S10C
N	—	F5S04C	F5S05C	F5S06C	—	—	—	F5S10C
R	—	F6S04	F6S05	F6S06	—	—	—	—
MD, MDS (old)	—	F7S04	F7S05	F7S06	—	—	—	F7S10C

#### High Performance Flex Shaft <sup>①②</sup>

Breaker Frame	Flexible Shaft Length in Feet (m)							
	3 (0.9)	4 (1.2)	5 (1.3)	6 (1.8)	7 (2.1)	8 (2.4)	9 (2.7)	10 (3.1)
	Catalog Number	Catalog Number	Catalog Number	Catalog Number	Catalog Number	Catalog Number	Catalog Number	Catalog Number
G	F0S03HP	F0S04HP	F0S05HP	F0S06HP	N/A	N/A	N/A	N/A
F	F1S03HP	F1S04HP	F1S05HP	F1S06HP	F1S07HP	F1S08HP	F1S09HP	F1S10HP
F (dual)	F1S03HPD	F1S04HPD	F1S05HPD	F1S06HPD	F1S07HPD	F1S08HPD	F1S09HPD	F1S10HPD
J	F2S03HP	F2S04HP	F2S05HP	F2S06HP	F2S07HP	F2S08HP	F2S09HP	F2S10HP
K	F3S03HP	F3S04HP	F3S05HP	F3S06HP	F3S07HP	F3S08HP	F3S09HP	F3S10HP
L and MDL	N/A	F4S04HP	F4S05HP	F4S06HP	N/A	N/A	N/A	F4S10HP
N	N/A	F5S04HP	F5S05HP	F5S06HP	N/A	N/A	N/A	F5S10HP
R	N/A	F6S04HP	F6S05HP	F6S06HP	N/A	N/A	N/A	N/A

### Flange-Mounted Handle Mechanisms

#### Type C371

Circuit Breaker or Motor Circuit Protector	Frame Size	Variable Depth Mounting Range Min./Max. <sup>②③</sup>	Operating Mechanism Only <sup>④</sup>	Operating Mechanism w/ 4-Inch Handle	
			Catalog Number	For NEMA 1-12 Enclosure Catalog Number	For NEMA 4/4X Enclosure Catalog Number
HMCP and Series C—EHD, FDB, FD, FDC, HFD, ED	150	6.50–16 (165.1–406.4)	<b>C371E</b>	<b>C371E1</b>	<b>C371E2</b>
HMCP and Series C—HJD, JD, JDB, JDC	250	6.50–16.63 (165.1–422.4)	<b>C371F</b>	<b>C371F5</b>	<b>C371F6</b>
HMCP and Series C—DK, HKD, KD, KDB	400	6.50–16.63 (165.1–422.4)	<b>C371F</b>	<b>C371F5</b>	<b>C371F6</b>
Series C—HLD, LD, LDC	600	8.50–22 (215.9–558.8)	<b>C371G</b>	<b>C371G5</b>	<b>C371G6</b>
Series C MD, MDS—(No MDL)	800	8.75–22 (222.3–558.8)	<b>C371K</b>	<b>C371K5</b>	<b>C371K6</b>
Series C—HND, ND, NDC	1200	9.75–22 (247.7–558.8)	<b>C371K</b>	<b>C371K5</b>	<b>C371K6</b>

#### Notes

<sup>①</sup> Suitable for GC/GD MCCB; not suitable for GMCP.

<sup>②</sup> For increased maximum allowable depth, see connecting rods on **Page V4-T2-446**.

<sup>③</sup> Dimensions shown are from panel flange surface.

<sup>④</sup> Does not include handle.

Type 4/4X handle mechanisms are available. Add Suffix **X** to complete catalog number. Add Suffix **I** to complete catalog number for IEC handle. Original narrow handle design (No C Suffix) is available. Remove C from catalog number.

When selecting the length of shaft, ensure minimum bending radius of 4 inches (101.6 mm) (5 inches, 12.7 mm for L-, N- and R-Frames) is maintained to operate properly. The standard method of shipment includes the mechanism preset at the factory; however, minor field adjustments may be required.

Dual breakers operator available on F-Frame only. Only the F, J and K can mount LH and RH all other RH only.

Approximate Dimensions in Inches (mm)

## 2

**Handle Only**

<b>Circuit Breaker Frame Size (Amperes)</b>	<b>NEMA Enclosure Type</b>	<b>Operating Handle Length</b>	<b>Catalog Number</b>
150	1/3R/3/12	4.00 (101.6)	<b>C371H1</b>
	4/4X	4.00 (101.6)	<b>C371H2</b>
	1/3R/3/12	6.00 (152.4)	<b>C371H3</b>
	4/4X	6.00 (152.4)	<b>C371H4</b>
250–1200	1/3R/3/12	4.00 (101.6)	<b>C371H5</b>
	4/4X	4.00 (101.6)	<b>C371H6</b>
	1/3R/3/12	6.00 (152.4)	<b>C371H7</b>
	4/4X	6.00 (152.4)	<b>C371H8</b>

**Channel Support Kit (Rod Not Supplied)**

For use to prevent bending of the operating handle mounting surface. This is especially useful when the operating handle is mounted on a channel in a multi-door enclosure.

<b>Amperes</b>	<b>Catalog Number</b>
600–1200	<b>C371CS6</b>

**Connecting Rods** <sup>①</sup>

<b>Application</b>	<b>Catalog Number</b>
Disconnect switches (30, 60, 100, 200 A sizes)	<b>C371CS1</b>
Circuit breakers (150, 250, 400 A sizes)	<b>C371CS1</b>
Circuit breakers (600, 800, 1200 A sizes)	<b>C371CS2</b>

**Note**

① Increase maximum allowable depth by 5 inches (127 mm).

Handle Extension



Contents

<i>Description</i>	<i>Page</i>
Handle Mechanisms—Series G . . . . .	<b>V4-T2-420</b>
High-Performance Rotary Handle Mechanisms . . . . .	<b>V4-T2-421</b>
Universal Rotary . . . . .	<b>V4-T2-426</b>
Direct (Close-Coupled) Handle Mechanisms . . . . .	<b>V4-T2-428</b>
Flex Shaft . . . . .	
Handle Mechanisms—Series C . . . . .	
High-Performance Rotary Handle Mechanisms . . . . .	<b>V4-T2-434</b>
Series C Rotary . . . . .	<b>V4-T2-438</b>
Direct (Close-Coupled) Handle Mechanisms . . . . .	<b>V4-T2-442</b>
Flex Shaft . . . . .	<b>V4-T2-444</b>
Product Selection . . . . .	<b>V4-T2-445</b>
Handle Extension . . . . .	<b>V4-T2-447</b>

Handle Extension

Product Description

- Suitable for use on two- or three-pole G-Frame
- Not included with J, K, L, M and N-Frame breakers; it must be purchased separately
- Included with R-Frame breakers

Product Selection

Handle Extension



Handle Extension ①②

Frame	Style Number
J, K	HEX3
L, M	HEX4
N	HEX5
R	HEX6

Notes

- ① Handle extension is not included with J, K, L, M and N-Frame breakers. It must be purchased separately.
- ② Handle extension is included with breaker with R-Frame breakers.