

PARTS LIST LISTE DES PIÈCES

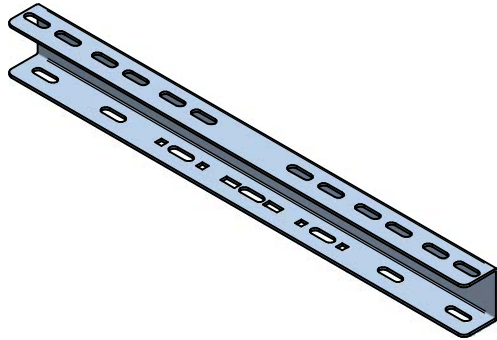

ITEM 1
ADAPTER PLATE
QTY 1



ITEM 2
CARRIAGE BOLT
1/4-20 X .75LG
QTY 2



ITEM 3
KEPS NUT, 1/4-20
QTY 2



ITEM 4
J-BOLT,
3/16-18 X 2.25LG
QTY 2



ITEM 5
NUT, 3/6-18
QTY 2



ITEM 6
LOCK WASHER, 3/16
QTY 2

1
A

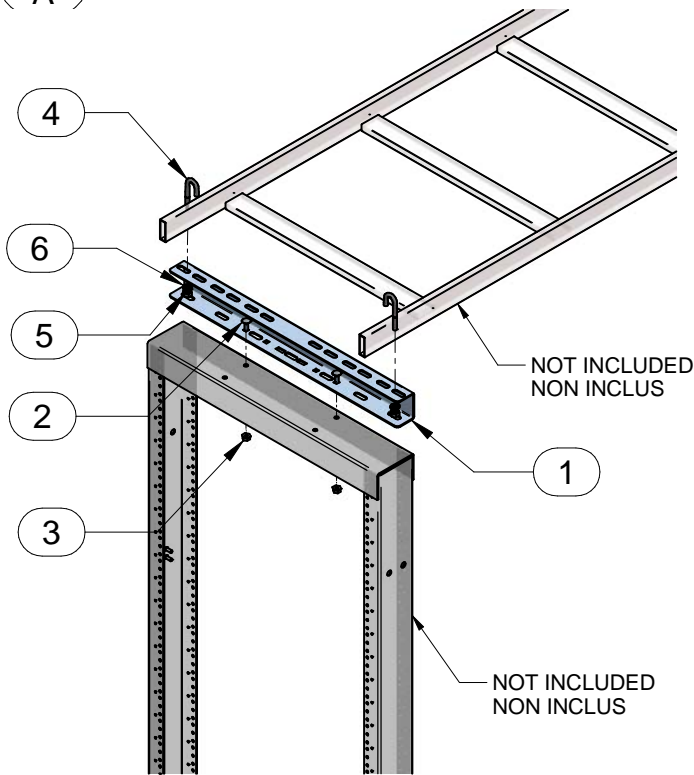

1
B

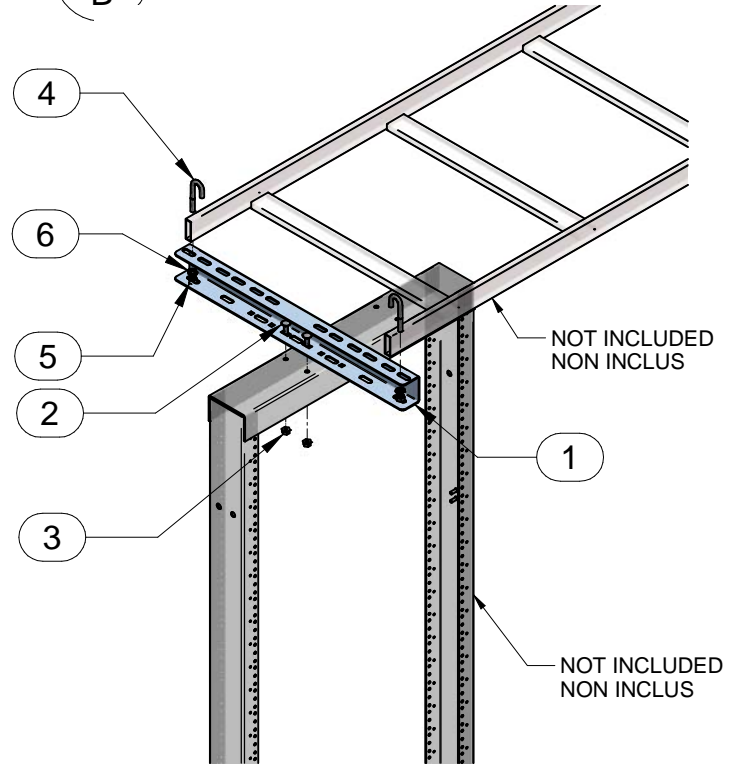

TOOL BOX



BOÎTE À OUTILS

7/16 Open Ended Wrench

7/16 Socket Driver



visit our website:
visitez notre site Web:

www.hammondmfg.com

3
A

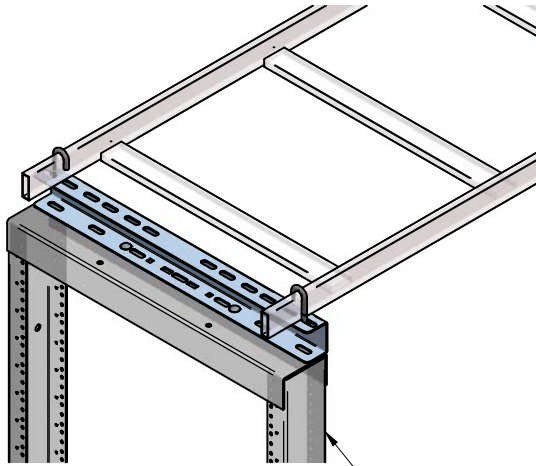

NOT INCLUDED
NON INCLUS

NOT INCLUDED
NON INCLUS

3
B

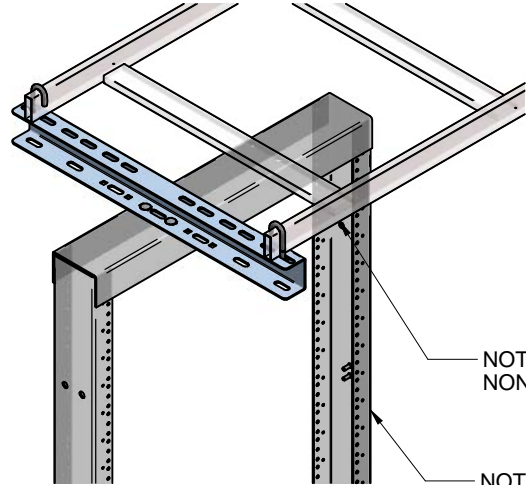

NOT INCLUDED
NON INCLUS

NOT INCLUDED
NON INCLUS

3
C

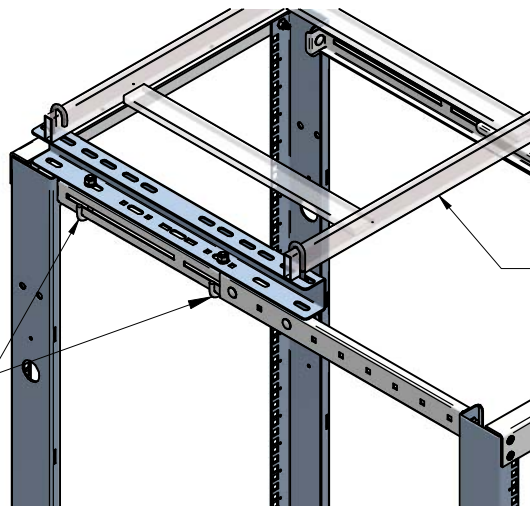

NOT INCLUDED
NON INCLUS

NOT INCLUDED
NON INCLUS

