

Catalog Numbers • Les Numéros de Catalogue • Los Números de Catálogo: LMDW-211, LMDW-220

Country of Origin: Made in China • Pays d'origine: Fabriqué en Chine • País de origen: Hecho en China
 Models ending in -U are BAA and TAA compliant (Product produced in the U.S.)

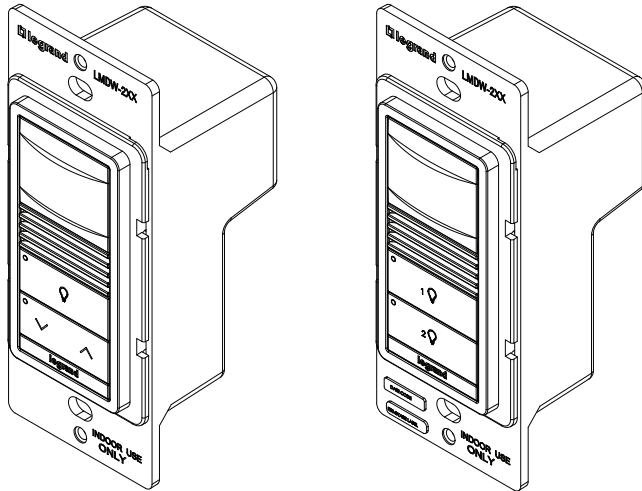

SPECIFICATIONS

Voltage	24VDC
Current Consumption	20mA
Power Supply	Wattstopper Room Controller
Connection to the DLM Local Network.....	2 RJ-45 ports
DLM Local Network Characteristics when using LMRC-11x/2xx room controllers:	
Provides low voltage power over Cat 5e cable (LMRJ).	
Supports up to 24 communicating devices, including 4 LMRC-10x or LMPL-101 max per each DLM Local Network.	
Free topology up to 1,000ft of low voltage cable.	
Environment	For Indoor Use Only
Operating Temperature	32° to 131°F (0° to 55°C)
Storage Temperature	23° to 176°F (-5° to 80°C)
Relative Humidity	5 to 95% (non condensing)
Patent Pending	

This unit is pre-set for Plug n' Go™ operation, adjustment is optional.

For full operational details, adjustment and more features of the product, see the DLM System Installation Guide provided with Wattstopper room controllers, and also available at www.legrand.us/wattstopper.

Installation shall be in accordance with all applicable regulations, local and NEC codes. Wire connections shall be rated suitable for the wire size (lead and building wiring) employed.
 For Class 2 DLM devices and device wiring: To be connected to a Class 2 power source only. Do not reclassify and install as Class 1, or Power and Lighting Wiring.
 Do not apply cleaning solvent directly onto unit. Apply cleaning solvent onto a cloth, then wipe the unit to clean it..

BUTTONS AND INDICATORS

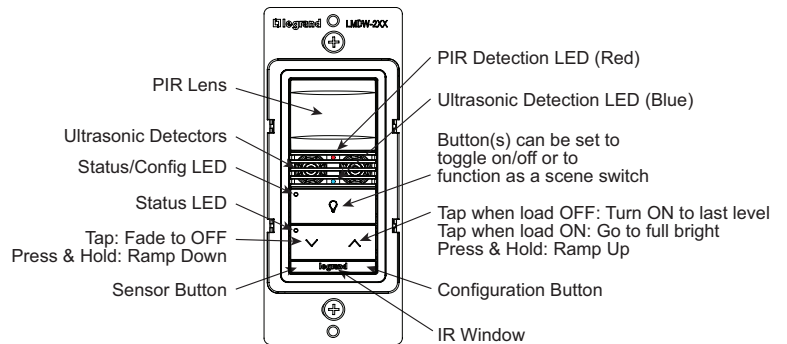

COVERAGE PATTERN

Do not obstruct the lens. **NOTE:** Plus 10° above horizon.

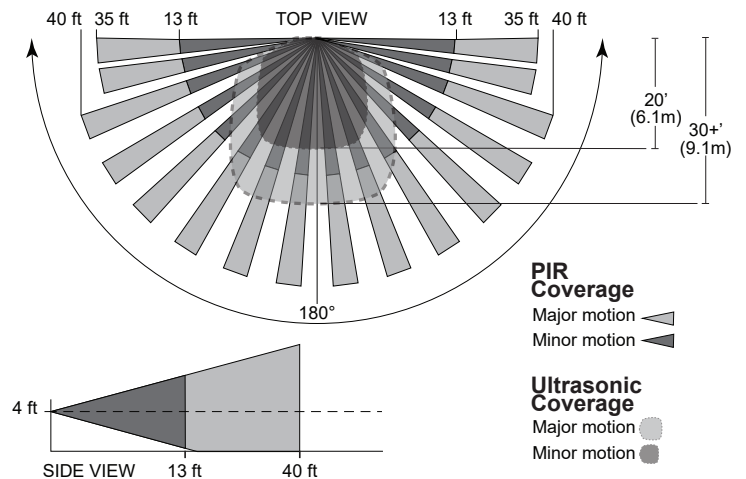

MOUNTING

WARNING: Do Not Install To Cover a Junction Box Having Class 1, 3 or Power and Lighting Circuits.

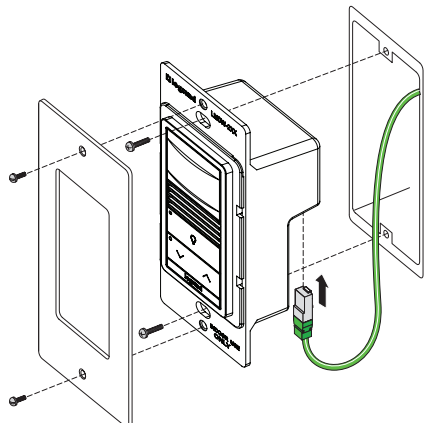

CONNECTIVITY

The illustrations below show examples of free-topology wiring. The LMDW communicates to all other Digital Lighting Management devices connected to the low voltage DLM Local Network, regardless of their position on the DLM Local Network.

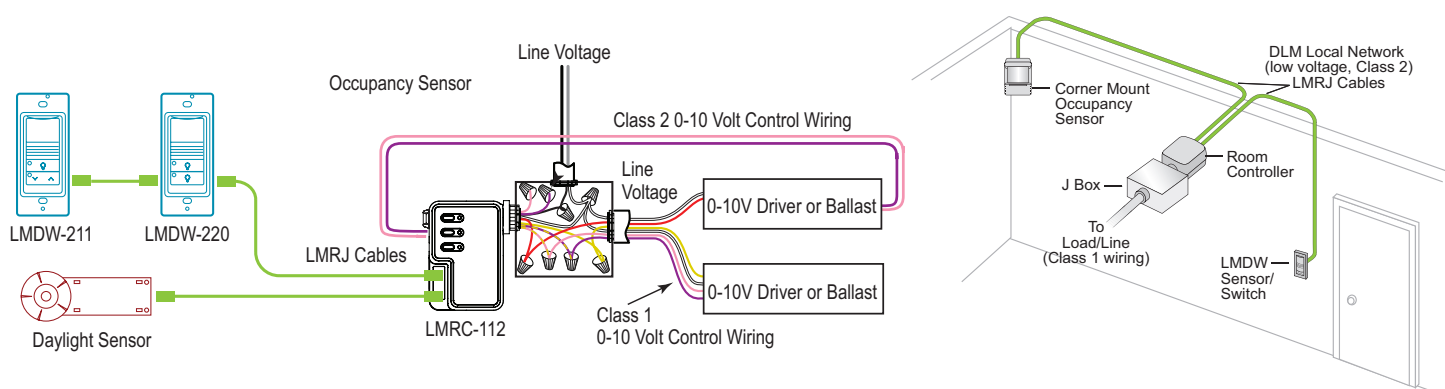

CAUTION: TO CONNECT A COMPUTER TO THE DLM LOCAL NETWORK USE THE LMCI-100. NEVER CONNECT THE DLM LOCAL NETWORK TO AN ETHERNET PORT – IT MAY DAMAGE COMPUTERS AND OTHER CONNECTED EQUIPMENT.

PLUG N' GO OPERATION (PNG)

Each load is automatically assigned to a switch button.

- If there is only one load it will default to Manual ON/Auto OFF. If there is more than one load then the first load will default to Auto ON/Auto OFF and the rest of the loads will default to Manual ON/Auto OFF.
- For the LMDW-220, if there is only a single load, the first button will turn the load on and the second button will turn the load off. If there are two loads, the first button will toggle load 1 and the second button will toggle load 2.
- If there are more than two loads, the last button controls all remaining loads, as shown in the drawing to right for the LMDW-220.
- For the LMDW-211, the button will switch all loads and the rocker will dim all loads.

Plug n' Go Load Binding

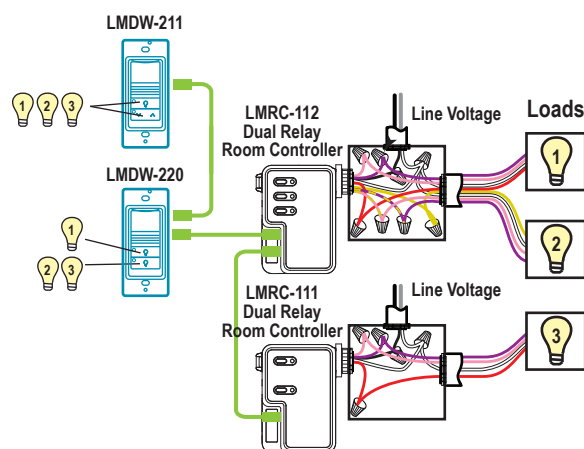

UNLOCKING AND LOCKING THE CONFIGURATION AND SENSOR BUTTONS

The Configuration button allows access to our patented Push n' Learn™ (PnL) technology to change the binding relationship between switch buttons and loads. The Sensor button is used for editing sensor parameters, entering Test Mode, and resetting the LMDW-2xx.

The configuration and sensor buttons will lock after any of the following events:

- ▶ PnG lock command is transmitted (occurs upon PnL exit)
- ▶ After twelve hours of being unlocked (first boot or a manual unlock)
- ▶ The button is manually locked (as described below).

Unlocking the Configuration and Sensor Buttons

1. To check if the buttons are unlocked, press the Configuration button on the right-side of the Legrand badge. If the top button LED flashes red, they are unlocked.
2. If the top button LED did not flash red, the buttons are locked. Press-and-hold the Configuration button and the top-most button on the switch simultaneously until the top button LED flashes red (approximately 3 seconds). This signals that the Configuration and Sensor buttons are unlocked.

Once unlocked, you can proceed to the PnL process or to edit sensor parameters.

Locking the Configuration and Sensor Buttons (Optional)

If the Configuration and Sensor buttons are unlocked and you wish to manually lock them, press-and-hold both the Configuration button and the top-most button on the switch simultaneously until the top button LED lights red (approximately 3 seconds).



UNIT ADJUSTMENT – PUSH N’ LEARN (PNL)

The Configuration and Sensor buttons must be unlocked before proceeding with PnL.

Step 1 Enter Push n’ Learn

1. Press and hold **only** the Configuration button for 3 seconds, until the Config LED on the switch begins to blink Red.
2. When you release the switch’s Configuration button, the red LED on other communicating DLM Local Network devices begins to blink.
3. The DLM Local Network is now in PnL mode. The Red LEDs continue to blink until you exit PnL mode.
4. All loads in the room turn OFF after entering PnL. After one second, one load turns ON. This is Load #1, which is bound to switch button #1 as part of the Plug n’ Go factory default setting. The White LED will be ON for all switch buttons and Blue LED for all sensors that are bound to this load.

NOTE: For the top button, since it is blinking red while in PnL, the LED for that button will alternate between Red and White if the button is bound to the load or alternate between Red and Off if the button is not bound to the load.

Step 2 Load selection

1. Press and release the Configuration button to step through the loads connected to the DLM Local Network. As each load turns ON note which devices (switch buttons and sensors) are showing the white LED or blue LED. These devices are currently bound to the load that is ON.
2. To unbind a switch button from a load, press the switch button while its white LED is ON. The white LED turns OFF to indicate the button no longer controls the load that is currently ON.
3. Pressing the switch button again while the load is ON rebinds the load to the button and the white LED illuminates.
4. By default, the sensor is bound to all loads in the room. To unbind the switch’s sensor from a load, press the Sensor button (left-side of the Legrand badge) while the blue sensor LED is ON. The blue LED turns OFF to indicate the sensor no longer controls the load that is currently ON.
5. Pressing the sensor button again while the load is ON rebinds the load to the sensor and the blue sensor LED illuminates.

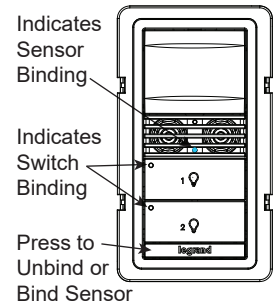

Step 3 Exit Push n’ Learn

Press and hold the configuration button until the red LED turns off, approximately 3 seconds.

DEFAULT SENSOR BEHAVIOR

	Load 1	Loads 2 or higher**	Plug Load
ON Mode Operation*	AUTO-ON	MANUAL-ON if switch is connected. AUTO-ON if no switch.	AUTO-ON
Blink Warning	OFF	OFF	OFF

* Auto-Off is enabled according to the sensor Time Delay when a sensor is bound to the load, regardless of whether the load was turned on automatically with occupancy or manually using a switch.

** Reference room/plug load controller documentation for maximum load limits.

MODIFYING SENSOR PARAMETERS

Occupancy Sensor parameters can be modified directly on the LMDW-2xx, or by using LMCS-100 software or the LMCT-100-2 IR Configuration Tool. To modify using the LMDW-2xx, the Configuration and Sensor buttons must be unlocked before modifying sensor parameters.

To adjust the default sensor parameter settings:

1. Press the Configuration button 3, 4, or 5 times to choose the setting to adjust (see the chart on the following page). The button must be pressed the desired number of times within a 5 second period.
2. Three seconds after successfully selecting a sensor setting, the red and blue LEDs will blink until exiting Sensor Configuration mode.

NOTE: While in Configuration mode, the **red LED** blinks corresponding to the currently selected parameter (3, 4, or 5 times), and **blue LED** blinks corresponding to the current value of that parameter (1 through 10 times). (For PIR and Ultrasonic Sensitivity, if the blue LED does not blink, that parameter is currently set to OFF.)

3. Press the Sensor button (left-side of the Legrand badge) to change the value for that setting based on the values in the following chart. Each time you press the Sensor Button, it will advance to the next value and the number of times the Blue LED blinks will change to show the new value. After reaching the maximum value (six presses for Time Delay and eleven presses for PIR and Ultrasonic Sensitivity), a subsequent button press will wrap back to the one button press value.

NOTE: When you **first** press the Sensor button after selecting the parameter to edit, the number of initial button presses will go directly to that value. So for example, if Time Delay is currently at 20 minutes and you press the SENSOR button twice, it will change to 10 minutes, **not** increase by two to 30 minutes. After that, each additional button press increases the value.

4. To return to normal operation, press the Configuration button the number of times corresponding to the currently selected setting (3, 4, or 5 times), also indicated by the red LED blink pattern.

NOTE: You must press the Configuration button the same number of times to exit edit mode. For example, if you press the Configuration button 4 times to edit PIR Sensitivity, pressing 3 times will **not** exit edit mode.

After exiting edit mode, you may repeat from step 1 to edit additional parameters.

	Configure Button Presses (Red LED)		
Sensor Button Presses (Blue LED)	3 Presses Time Delay	4 Presses PIR Sensitivity	5 Presses Ultrasonic Sensitivity
1 Press	5 minutes	10%	10%
2 Presses	10 minutes	20%	20%
3 Presses	15 minutes	30%	30%
4 Presses	20 minutes	40%	40%
5 Presses	25 minutes	50%	50%
6 Presses	30 minutes	60%	60%
7 Presses		70%	70%
8 Presses		80%	80%
9 Presses		90%	90%
10 Presses		100%	100%
11 Presses		0% (Off) – Blue LED will not blink	0% (Off) – Blue LED will not blink

Default Values Highlighted

ENTERING TEST MODE

Test Mode allows you to quickly determine the coverage area of the LMDW-2xx by setting Time Delay to 5 seconds. You can then move around till the sensor triggers the lights, then move out of range and wait 5 seconds (or until the lights turn Off) before trying again.

To turn Test Mode On, first unlock the Sensor button. Then press and hold the Sensor button for 3 to 10 seconds. The red LED will turn on. To exit Test Mode, press and hold the Sensor button for 3 to 10 seconds again. The blue LED will turn on, indicating it has exited.

RESETTING THE LMDW-2XX

To reset the LMDW-2xx press and hold the Sensor button for 10 to 20 seconds. Both the red and blue LEDs will turn on. Once you release the button, the LMDW-2xx will reset to default values.

If you press and hold the Sensor button for more than 20 seconds, the red LED will turn on and the blue LED will blink. All wired sensors in the room will reset to default values.

TROUBLESHOOTING

Loads do not operate as expected.

LEDs don't light, display is off	<ol style="list-style-type: none"> 1. Check to see that the sensor is connected to the DLM local Network. 2. Check for 24VDC input to the sensor: Plug in a different DLM device at the sensor location. If the device does not power up, 24VDC is not present. <ul style="list-style-type: none"> • Check the high voltage connections to the room controller. • If high voltage connections are good and high voltage is present, recheck DLM local Network connections between the sensor and the room controller.
The wrong lights are controlled	<ol style="list-style-type: none"> 1. Configure the sensor to control the desired lights using the Push n' Learn adjustment procedure.
LEDs turn ON and OFF but load doesn't switch	<ol style="list-style-type: none"> 1. Make sure device is not in PnL. 2. Check load connections to room controller.

FCC REGULATORY STATEMENTS

This device complies with Part 15 of the FCC Rules. Operation is subject to the following two conditions: (1) This device may not cause harmful interference, and (2) this device must accept any interference received, including interference that may cause undesired operation.

NOTE: This equipment has been tested and found to comply with the limits for a Class B digital device, pursuant to part 15 of the FCC Rules. These limits are designed to provide reasonable protection against harmful interference in a residential installation. This equipment generates, uses and can radiate radio frequency energy and, if not installed and used in accordance with the instructions, may cause harmful interference to radio communications. However, there is no guarantee that interference will not occur in a particular installation. If this equipment does cause harmful interference to radio or television reception, which can be determined by turning the equipment off and on, the user is encouraged to try to correct the interference by one or more of the following measures:

- Reorient or relocate the receiving antenna.
- Increase the separation between the equipment and receiver.
- Connect the equipment into an outlet on a circuit different from that to which the receiver is connected.
- Consult the dealer or an experienced radio/TV technician for help.

Changes or modifications to this product not expressly approved by Legrand/Watt Stopper could void the user's authority to operate this product.

WARRANTY INFORMATION

Wattstopper warrants its products to be free of defects in materials and workmanship for a period of five (5) years. There are no obligations or liabilities on the part of Wattstopper for consequential damages arising out of, or in connection with, the use or performance of this product or other indirect damages with respect to loss of property, revenue or profit, or cost of removal, installation or reinstallation.

INFORMATIONS RELATIVES À LA GARANTIE

Wattstopper garantit que ses produits sont exempts de défauts de matériaux et de fabrication pour une période de cinq (5) ans. Wattstopper ne peut être tenu responsable de tout dommage consécutif causé par ou lié à l'utilisation ou à la performance de ce produit ou tout autre dommage indirect lié à la perte de propriété, de revenus, ou de profits, ou aux coûts d'enlèvement, d'installation ou de réinstallation.

INFORMACIÓN DE LA GARANTÍA

Wattstopper garantiza que sus productos están libres de defectos en materiales y mano de obra por un período de cinco (5) años. No existen obligaciones ni responsabilidades por parte de Wattstopper por daños consecuentes que se deriven o estén relacionados con el uso o el rendimiento de este producto u otros daños indirectos con respecto a la pérdida de propiedad, renta o ganancias, o al costo de extracción, instalación o reinstalación.