

# PLUG LOAD CONTROLLER

LMPL-101

Plenum-rated controller with line voltage relay and switching power supply

Component of Digital Lighting Management integrated control systems

Plugs to other components using Cat 5e cables with RJ45 connectors eliminating wiring errors



Plug n' Go automatic configuration and Push n' Learn for personalization

Accepts occupancy sensor signal for energy saving control of plug loads



## DESCRIPTION

LMPL-101 Plug Load Controllers include a 20 amp relay for on/off control of connected outlets, and a high-efficiency switching power supply. They are part of a Wattstopper Digital Lighting Management (DLM) system, and enable energy-efficient control of plug loads.

## OPERATION

LMPL-101 Plug Load Controllers operate on 120 volts and provide Class 2 power to sensors and switches via the DLM local network. Once powered up, Plug n' Go automatically configures system components for the most energy-efficient operation. The plug load controllers then switch controlled outlets on and off in response to input from any communicating occupancy sensors. The DLM system may be reconfigured using Push n' Learn without the need for tools or a PC. Additionally, the LMCT-100-2 wireless configuration tool can be used for load configuration.

## PLUG N' GO & PUSH N' LEARN CONFIGURATION

Plug n' Go automatic configuration establishes system functionality based on the installed components. Plug Load Controllers are initially controlled by all of the occupancy sensors on the DLM local network, and default to automatic on/off operation whether or not there is a switch on the local network. DLM system operation may be reconfigured using Push n' Learn. As an example, a selected switch button may be bound to a plug load controller for manual-off control of outlets. Similarly, the plug load controller could be bound only to selected occupancy sensors.

## APPLICATIONS

LMPL-101 Plug Load Controllers ensure that energy is not wasted when portable loads such as task lighting and computer monitors are plugged into building outlets. Plug Load Controllers should be installed to switch outlets for lighting and non-essential equipment in private offices, open offices, lunch rooms and break rooms and other areas in commercial buildings. They are appropriate for LEED projects and help building owners realize a higher return on investment on energy code-required occupancy sensors.

## FEATURES

- Plug n' Go™ automatic configuration for quick installation and maximum energy savings
- Push n' Learn™ functionality for personalization without the need for tools or a PC
- Digital Lighting Management components plug together on a free-topology Cat 5e DLM local network
- Load On/Off button
- LED indicates status of connected load
- 3 RJ45 ports with integral strain relief and hinged dust cover
- Zero-crossing circuitry for reliability and increased product life
- Attach to standard electrical box through ½" knockout; UL2043 plenum rated
- Ships with "Sensor Controlled" labels for connected outlets
- The product meets the materials restrictions of RoHS
- Qualifies for ARRA-funded public works projects

PROJECT	LOCATION/ TYPE

## SPECIFICATIONS

- Input/output voltage: 120VAC, 50/60Hz
- Load ratings:
  - Ballast: 20A
  - Incandescent: 20A
  - Motor load: 1Hp
- DLM local network parameters:
  - Maximum current: 800mA
  - Maximum cable (Cat5e): 150' per intelligent device on local DLM network, up to 1,000' max.
  - Up to 64 loads
  - Communicating Device Limitation:
    - When all power supplies are 10X-Series: 24 Devices.
    - When other power supplies are present: 48 Devices.
  - Maximum of (5) 10X-Series power supplies (LMRC-10X, LMPL-101, LMPB-100) per local network.
- Class 2 output to DLM local network: 24VDC, 150mA across 3 RJ45 ports
- Operating conditions: for indoor use only; 32-104°F (0-40°C); 5-95% RH, non-condensing
- UL (88T9) and cUL listed
- FCC part 15 compliant
- Five year warranty

## CONTROLS & MOUNTING

### Controls and Dimensions

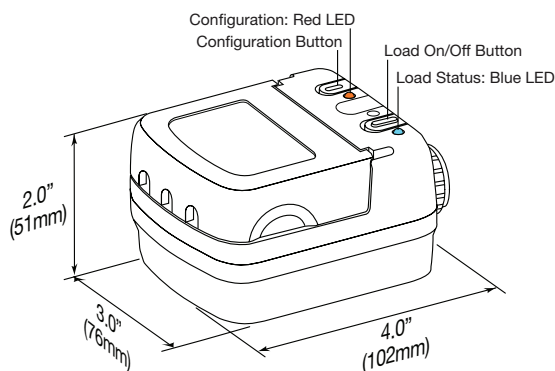

LMPL-101 Plug Load Controllers include a 1/2" (12.7mm) threaded nipple and locking ring.

### Mounting and Wiring

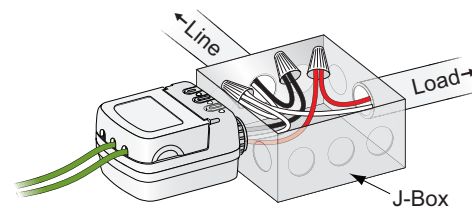

Mounting outside a j-box (plenum space). Two LMPL-101 and/or LMRC-100 Series Room Controllers may be mounted to the j-box.

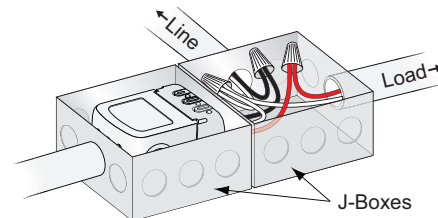

Mounting inside a j-box.

## CONNECTING

### Sample Connection Diagram for Bi-Level Lighting and Plug Load Control

Plug DLM local network components together in any configuration using Cat 5e cables with RJ45 connectors.

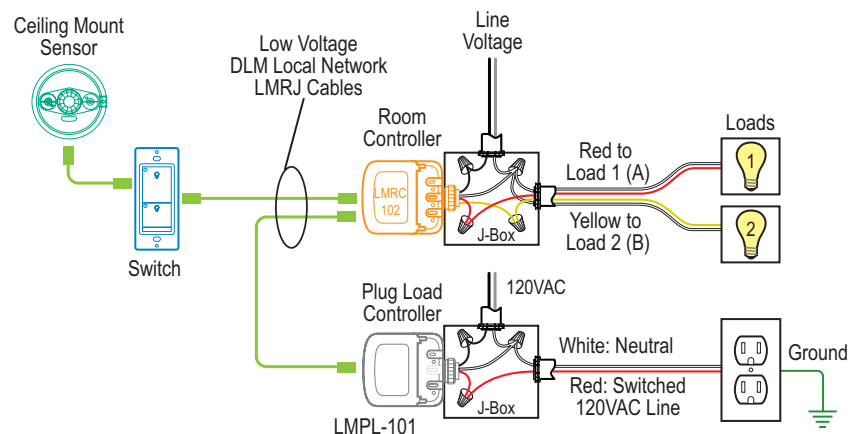

## ORDERING INFORMATION

			Load Rating			
Catalog #	Description	Single Phase Voltage 50/60Hz	Ballast	Incan	Motor	Class 2 Outputs
<input type="checkbox"/> LMPL-101	Plug Load Controller	120VAC; 50/60Hz	20A	20A	1 Hp	24 VDC; 150 mA
<input type="checkbox"/> LMPL-101-U	Plug Load Controller, BAA/BABA compliant*					
<input type="checkbox"/> LMCT-100-2	Digital Wireless Configuration Tool					
<input type="checkbox"/> LMCT-100-2-U	Digital Wireless Configuration Tool, BAA/BABA compliant*					

\*Product is compliant with the Buy American Act and Build America, Buy America Act