

ON/OFF ROOM CONTROLLERS

LMRC-100 SERIES

Plenum-rated controllers with line voltage relay(s) and switching power supply

Components of Digital Lighting Management integrated control systems

Plug to other components using Cat 5e cables with RJ45 connectors eliminating wiring errors



Plug n' Go automatic configuration for maximum energy efficiency

Support energy saving manual-on and bi-level lighting control strategies



DESCRIPTION

LMRC-100 Series Digital Room Controllers include one or two relay(s) for on/off control of a total of 20 amps, and a high-efficiency switching power supply. They are the foundation of a Wattstopper Digital Lighting Management (DLM) system, and allow integration of occupancy sensors, daylighting sensors and switches for energy-efficient lighting control.

OPERATION

LMRC-100 Series Room Controllers operate on one, single phase 120/230/240/277 volt, 20 amp, feed and provide Class 2 power to sensors and switches via the DLM local network. Once powered up, Plug n' Go automatically configures system components for the most energy-efficient operation. The room controllers then switch lighting or motor loads on and off in response to input from the communicating devices. The DLM system may be reconfigured using Push n' Learn without the need for tools or a PC. Additionally, the LMCT-100-2 wireless configuration tool can be used for load configuration.

FEATURES

- Plug n' Go™ automatic configuration for quick installation and maximum energy savings
- Push n' Learn™ functionality for personalization without the need for tools or a PC
- Digital Lighting Management components plug together on a free-topology Cat 5e DLM local network
- Zero-crossing circuitry for each relay for reliability and increased product life
- On/Off button for each load
- LED indicates status of connected load
- 3 RJ45 ports with integral strain relief and hinged dust cover
- Attach to standard electrical box through 1/2" knockout; UL (2043) plenum rated
- The product meets the materials restrictions of RoHS
- BAA/BABA-compliant model available

PLUG N' GO AUTOMATIC CONFIGURATION

DLM room controllers manage Plug n' Go automatic system configuration, which establishes functionality based on the installed components. When room controllers are connected only to occupancy sensors, the system defaults to automatic on/off operation. If a wall switch is added to a system with one load, the load defaults to manual-on/automatic-off operation. If there is a wall switch and multiple loads, load one turns on automatically, while additional loads default to manual-on control; all loads turn off automatically.

APPLICATIONS

LMRC-100 Series Room Controllers are ideal for single or multiple zone on/off lighting control applications. The LMRC-101 helps specifiers comply with basic On/Off requirements, while the LMRC-102 is designed for bi-level switching. Both controllers are appropriate for applications in private offices, open offices, conference rooms, lunch rooms and break rooms in any commercial building.

PROJECT

LOCATION/
TYPE

SPECIFICATIONS

- Input/output voltage: Single Phase 120/230/240/277VAC; 50/60Hz
- Maximum 20A combined load per Room Controller; each relay rated for:
 - Ballast or incandescent: 20A
 - E-ballast: 16A @ 120/277VAC (per NEMA 410)
 - Motor load: 1Hp
- DLM local network parameters:
 - Maximum current: 800mA
 - Maximum cable (Cat5e): 150' per intelligent device on local DLM network, up to 1,000' max.
 - Up to 64 loads
 - Communicating Device Limitation:
 - When all power supplies are 10X-Series: 24 Devices.
 - When other power supplies are present: 48 Devices.
 - Maximum of (5) 10X-Series power supplies (LMRC-10X, LMPL-101, LMPB-100) per local network.
- Class 2 output to DLM local network: 24VDC, 150mA across 3 RJ45 ports
- Operating conditions: for indoor use only; 32-104°F (0-40°C); 5-95% RH, non-condensing
- UL (E101196) and cUL listed
- UL (2043) plenum rated
- FCC part 15 compliant
- Five-year warranty

CONTROLS & MOUNTING

Controls and Dimensions

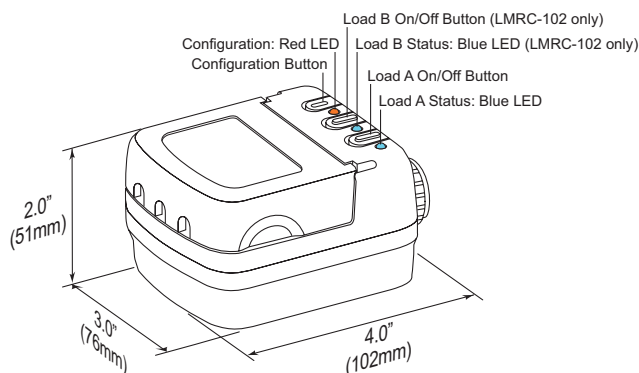

LMRC-100 Series Room Controllers include a 1/2" (12.7mm) threaded nipple and locking ring.

Mounting and Wiring

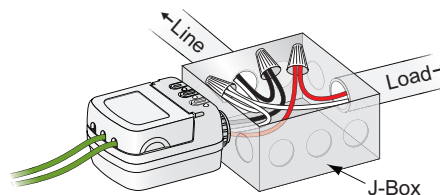

Mounting outside a j-box (plenum space). Two LMRC Room Controllers may be mounted to the j-box.

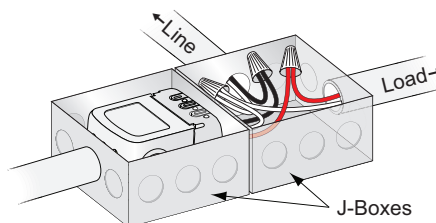

Mounting inside a j-box. Low voltage wiring is run to the LMRC Room Controller in conduit.

CONNECTING

Sample Connection Diagram for Bi-Level Control Using LMRC-102

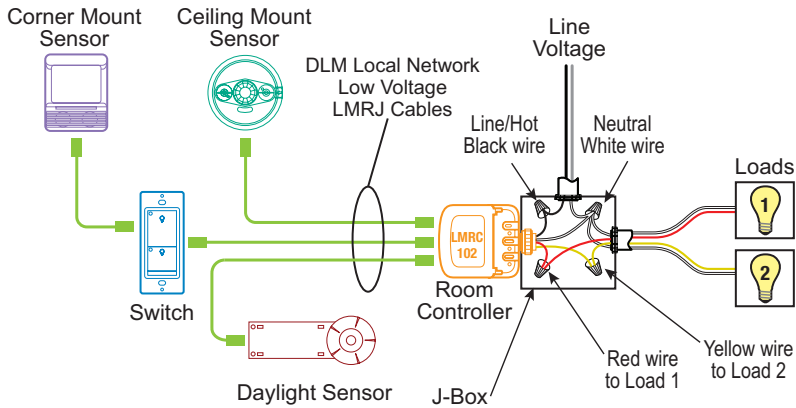

Plug DLM local network components together in any configuration using Cat 5e cables with RJ45 connectors.

ORDERING INFORMATION

Catalog #	Description	Total Load Rating (any/all relays)				Class 2 Output
		Single Phase Voltage 50/60Hz	Incand.	Ballast	Motor	
<input type="checkbox"/> LMRC-101	Single Relay Room Controller	120/230/240/277VAC	20A	20A	1 Hp	24VDC 150mA
<input type="checkbox"/> LMRC-102	Dual Relay Room Controller					
<input type="checkbox"/> LMRC-102-U	Dual Relay Room Controller, BAA/BABA compliant*					
<input type="checkbox"/> LMCT-100-2	Digital Wireless Configuration Tool					
<input type="checkbox"/> LMCT-100-2-U	Digital Wireless Configuration Tool, BAA/BABA compliant*					

*Product is compliant with the Buy American Act and Build America, Buy America Act