

Catalog Number • Numéro de Catalogue • Número de Catálogo: LS-102

Country of Origin: Made in China • Pays d'origine: Fabriqué en Chine • País de origen: Hecho en China

SPECIFICATIONS

Light Sensor range	1 to 1400 footcandles
ON Setpoint range	1 to 850 footcandles
Automatic Deadband.....	25%, 50%, 75%, 100% (above the ON setpoint)
Status Indicator	Multifunction green LED
Power requirements	12/24 VDC, min 10 mA
Total power requirements are determined by the controlled device.	
Output signal	12/24 VDC, max 120 mA
Location.....	Suitable for dry, interior locations
Environment	50° to 104° F, less than 90% rh
Dimensions	2.4" diameter x 0.7" depth
 (61mm x 17mm)



DESCRIPTION

The Wattstopper LS-102 is an interior photosensor that automatically turns a zone of lights **ON** and **OFF** based on daylight levels. It is a low voltage device intended to signal a power pack or relay panel.

The LS-102 is designed to require minimal adjustment at startup. For more advanced applications, an onboard display and two pushbuttons allow for adjustments, if needed. The display is hidden under a removable cover. To assist with adjustment, the LS-102 displays the current light level reading. The LS-102 is designed to be either ceiling-mounted or wall-mounted. It has a wide-range light sensor capable of measuring from 1 to 1400 footcandles.

SELECTING A LOCATION

The LS-102 controls lights in areas that receive enough daylight that the electric lights can be reduced or switched **OFF**. It is important to select a location for the LS-102 where the daylight is representative of the daylight throughout the controlled zone. Note the path of shadows. Daylighting control will be problematic if part of a controlled zone is in shadows, while another part has plentiful daylight.

When the primary source of daylight is a window (sidelighting), the LS-102 is typically ceiling mounted within the daylit zone which extends 12 feet or less in from the window. A good location is often between the window and the first row of fixtures. Figure 1 shows a typical mounting location for a sidelit application.

When the primary source of daylight is a skylight (toplighting), there are several options for mounting the LS-102. The recommended mounting locations are shown in Figure 2.

1. Ideally, the sensor is mounted on the South sidewall looking North across the light well.
2. It could also be mounted on the ceiling next to the skylight, looking down at the floor.

A skylight may produce 5000 footcandles or more. If the sensor is mounted so that it looks up into the skylight, the daylight will exceed the maximum **OFF** setpoint of 1275fc, which is too low for this orientation.

Closed Loop Photosensor

The LS-102 should be used as a closed loop device. The LS-102 should view both daylight and light from the controlled electric lights.

It is critical to have enough separation between the **ON** and **OFF** settings (known as deadband) to compensate for the reduction of the controlled lights. If not, when the controlled lights switch **OFF**, the light level will fall below the **ON** setpoint and the lights will switch back **ON**.

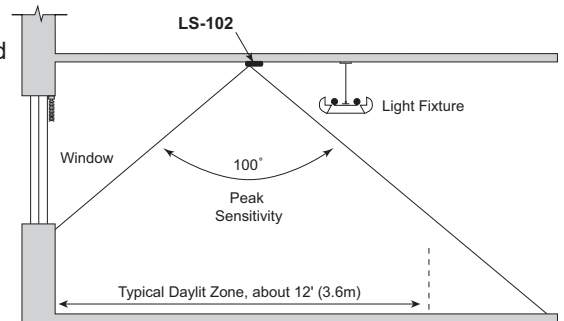

Figure 1: LS-102 Field of view, sidelight application

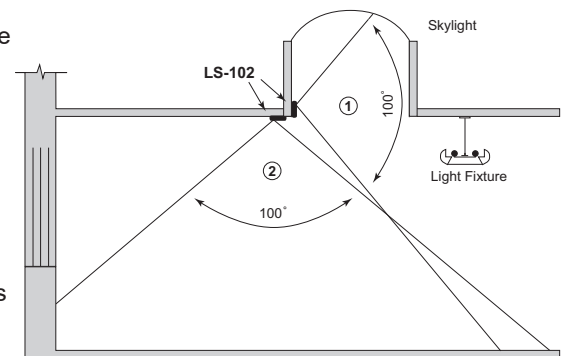

Figure 2: LS-102 Skylight application

AUTOMATIC CALIBRATION OPERATION

The LS-102 features automatic calibration calculation. Auto Cal invokes a procedure to select an appropriate value for the **ON** setpoint. As part of this process, the controlled load is first turned **ON** for a period of two minutes, to warm up the lamps, and then is switched **OFF** eight times.

At the completion of the calibration, a new value for the **ON** and **OFF** setpoint is automatically selected; these values can be viewed in the menus.

MANUAL OPERATION

The LS-102 features adjustable **ON** and **OFF** setpoints, **OFF** time delay as well as several features to simplify adjustment. For basic operation, these three parameters are all that may need to be adjusted.

While the **ON** and **OFF** setpoints are independently adjustable, the LS-102 features a built-in minimum deadband. Therefore, these two setpoints are always automatically separated by at least a minimum amount of deadband.

When the sensed light level drops below the **ON** setpoint for 20 seconds, the output signal switches **ON**. In the LS-102's default operation, this means that the LS-102 provides 24 VDC on the output (blue wire) when the lights should be **ON**. However, it is also possible to invert the output state. (Please see "Invert output" for further explanation.)

Adjusting the **ON** setpoint also automatically adjusts the **OFF** setpoint to maintain the programmed deadband. Once the **ON** setpoint is changed, you can further adjust the **OFF** setpoint. In applications where the LS-102 sees the lighting from the controlled fixtures, it is important to have the **ON** and **OFF** setpoint separated by a deadband of at least as much as the light provided by the controlled fixture.

Test Mode

The Test mode temporarily shortens all of the time delays so that the light level switching functions can be quickly tested. Test mode is invoked in the installation process in two ways.

- After either an **ON** or **OFF** setpoint has been changed, the LS-102 remains in Test mode for one minute. The LED blinks on and off rapidly to indicate Test mode. During this minute, test the LS-102 operation by either blocking the light reaching the sensor or by shining a bright light into the sensor. At the end of the minute, the normal time delays are reinstated.
- Test mode can be activated for a longer period through a menu item on the display. From the Test mode menu, you can turn on Test mode for 30 minutes. Once turned on, it can also be turned off from the Test mode menu.

Temporary Override

When using the display and buttons, it is possible to temporarily override the output **ON** or **OFF** from the display and onboard buttons. This feature is useful for observing that the correct lights are being controlled and all other components in the system are functioning correctly. (Please see the Display functions for further explanation.)

Invert output

This feature is used to control devices that require a +24 VDC signal when the lights should be turned **OFF** and 0 VDC when the lights should be turned **ON**. The normal operation of the LS-102 provides a +24 VDC signal when the lights should be turned **ON**, but using this feature, the operation can be reversed from the Adjustment Menu Setup display to satisfy the application.

Wall switch override option (see Figures 9 & 10)

The LS-102 provides a connection for an optional low voltage, normally-open, momentary-contact wall switch override.

This switch can be used to temporarily turn the lights **ON** when the LS-102 has switched them **OFF** because the light level is above the setpoint. When the wall switch is pressed, the lights switch **ON**, and automatic light level control is temporarily suspended for one hour. If during this period the wall switch is pressed again, the override is canceled and the lights are restored to automatic control.

The wall switch requires a two-wire momentary switch. See Figure 7 for more information.

Hold ON while occupied

This is an optional feature that prohibits high light levels from turning **OFF** the controlled light as long as the space remains occupied. This feature allows energy savings from daylighting control while limiting impact on occupants who might be distracted or annoyed if the lights switch **OFF** while they are in the space.

This feature requires that the signal wire from an occupancy sensor be connected to the LS-102. See Figure 8.

The LS-102 will not switch **OFF** while an occupancy signal (+24 VDC) is present on the white wire.

This function is enabled or disabled from the display's Adjustment Menu SETUP submenu. It allows the occupancy signal to be connected to the LS-102 at installation but later be ignored without having to disconnect it.

INSTALLATION

The LS-102 is designed to be mounted in either of two ways.

For suspended ceiling tile, a threaded nipple with a retaining nut is attached to the LS-102. See Figure 3.

For sheetrock or other solid surfaces, first remove the threaded nipple by squeezing it near the base of the LS-102. Then use the two screw holes located under the cover. Screws are not provided. Select #6 pan head screws appropriate for the mounting surface, typically about 7/8" long.

For measuring light, the rotation of the light sensor is not critical, but it may simplify setup and adjustment. Rotate the LS-102 so you can approach it from the side with the status LED. In a typical ceiling application, rotate the LS-102 so that the light sensor is nearest the window. In a wall mount application, it should be rotated so that the light sensor is near the top.

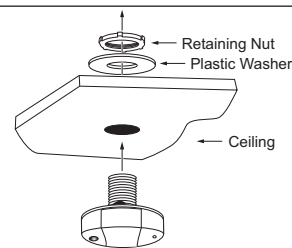

Figure 3: Ceiling tile mount

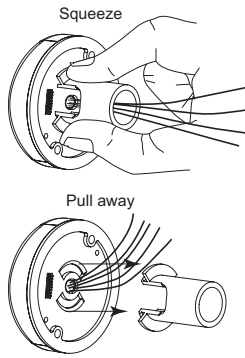

Figure 4: Removing the nipple from the back side of LS-102

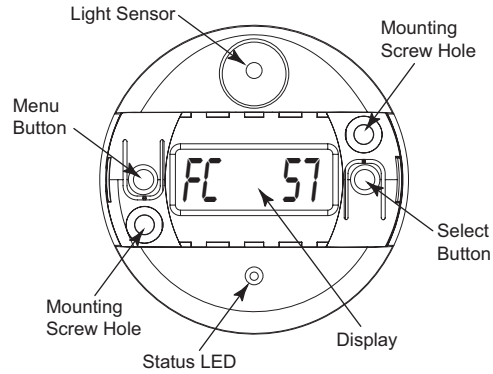

Figure 5: Features and orientation

WIRING

IMPORTANT: All low voltage wiring must be isolated from any line voltage wiring. Low voltage wiring should not be installed within the same conduit as line voltage wiring.

The unit has 5 color-coded wires. Connect to wires with insulation rated for the application. Normally recommended wire is 18 AWG 3 or 4 conductor cable with 300 Volt insulation. When the optional wall switch override is used, a separate 18 AWG-2 conductor with 300 volt insulation is recommended.

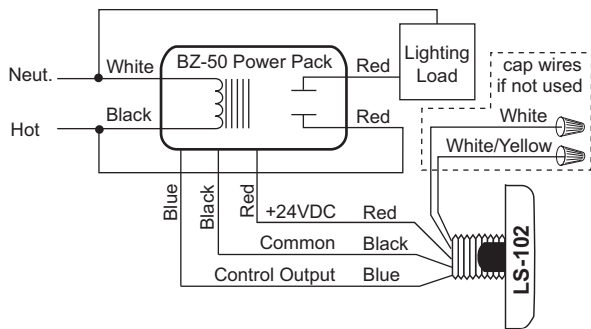

Figure 6: Basic LS-102 connections

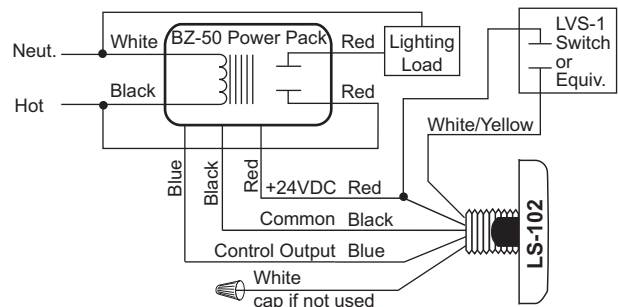

Figure 7: LVS-1 Override switch wiring

Using with the BZ-150 for Hold OFF while unoccupied

In this configuration, the occupancy sensor overrides the LS-102's light level input so that even when the light sensor sends a low light level signal to turn the lights **ON**, if the area is not occupied, the lights stay **OFF**. This application requires the use of a BZ-150 power pack with its switch set to **Auto-ON**. One adjustment needs to be made in the LS-102 Setup Submenu (see **Adjustment Menu** on page 4):

Output must be reversed by setting: **OUT INV**

Figure 8 shows the wiring for this application. Notice that there is an optional LVS-1 Switch included. In this configuration the occupant may temporarily override the LS-102 signal to turn lights **ON** even when light levels are high. Pressing the LVS turns the lights **ON** and automatic control will suspend for one hour. If during this period the wall switch is pressed again, the override is canceled and the lights return to automatic control.

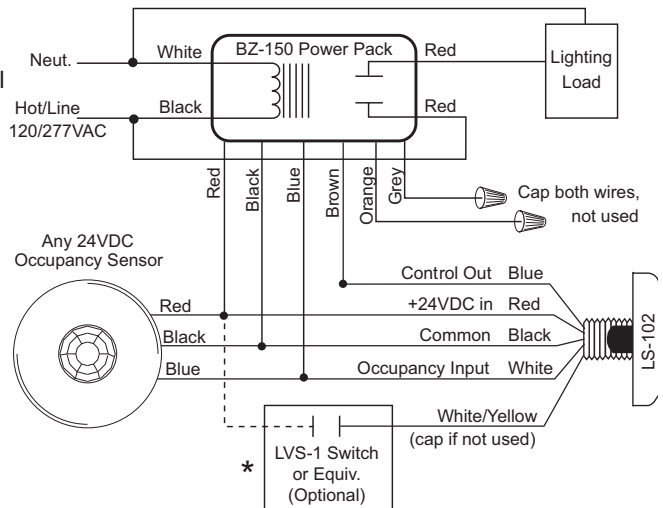

Figure 8: Occupancy Sensor, providing Hold OFF when unoccupied, ON when occupied AND low light level



WARNING: TURN THE POWER OFF AT THE CIRCUIT BREAKER BEFORE WIRING.



QUICK START TO ACTIVATING THE LS-102 FOR AUTOMATIC OPERATION

1. Complete all wiring and turn on the power to the LS-102, all accessories and loads.
2. Verify that the display shows LS102 ## (the current software version).
3. Press the MENU button six times then press SELECT once and verify that the display shows AUTO CAL.
4. Remove any objects that may affect the LS-102 light level reading (ladder, persons, or temporary objects).
5. Press SELECT once to start calibration. LED starts flashing off briefly once every four seconds.
6. Lights turn **ON** for two minutes, then cycle eight times for automatic setpoint selection.
7. When LED stops flashing, verify setpoints automatically selected. If the selected setpoints are not acceptable, proceed to manual calibration.

QUICK START TO ACTIVATING THE LS-102 FOR MANUAL OPERATION

1. Multiply the LS-102 FC reading with the desired light level at the task surface.
2. Place a light meter at the task surface.
3. To calculate the **ON** setpoint, step 1 value must be divided by step 2 value.
4. Press the Menu button until the **ON** menu appears, then use the select button to choose the **ON** setpoint closest to the value computed in step 3.
5. Press the Menu button on the LS-102 one time and store the desired **OFF** setpoint value.
The display automatically shuts down after 10 minutes without a button press.
6. Attach the cover plate onto the LS-102.

MANUAL OPERATION OF THE LS-102

All adjustments are made using the display and two buttons. Access the display by removing the cover. Set it safely aside. The display is oriented so that the letters are right side up when the light sensor is at the top, see Figure 7.

Buttons

There are two buttons, one on each side of the display, labeled **Menu** and **Select**. The Menu button moves the display forward through the menus. The **Select** button has two functions:

1. Press and release **Select** to step through the adjustment choices.
2. Press and hold **Select** until **MEM** appears in the display to change the adjustment to the selection shown in the display.

Display

When the LS-102 is powered up, the display shows: LS102 ##

"##" indicates the product's internal version number. This display also occurs if the LS-102 is reset to factory defaults.

The display goes to sleep when there is no activity. If no buttons are pressed for 10 minutes, then the display goes blank. Pressing either button wakes up the display.

The Adjustment Menu

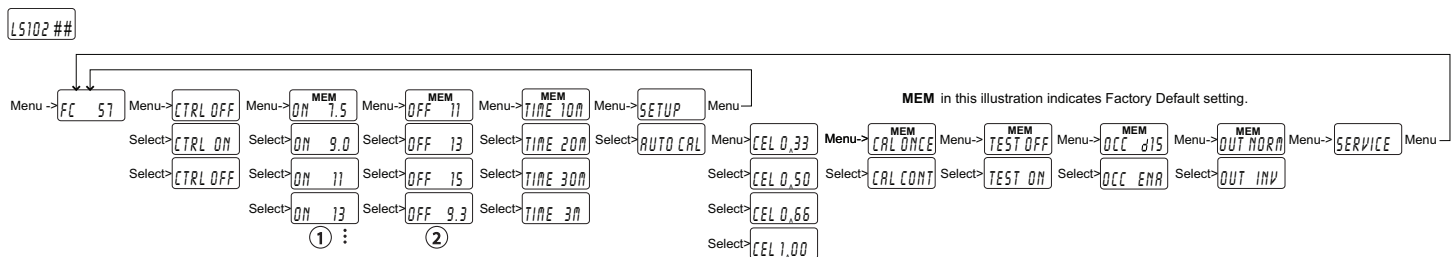

- ① Selections display beginning with the currently programmed setting and advance upward.
When the maximum ON Setpoint is reached (850fc) the selections start over at 1.0
Selections are: 1.0, 1.2, 1.5, 1.8, 2.2, 2.7, 3.3, 4.0, 5.0, 6.0, 7.5, 9.0, 11, 13, 16, 20, 25, 30, 35, 45, 60, 90, 125, 180, 250, 325, 400, 475, 550, 625, 700, 775, 850.
- ② OFF selections are automatically calculated based on the ON Setpoint. The default deadband is 50% above the ON Setpoint. Press the Select button to change the deadband percentage: 25%, 50%, 75% or 100% above the ON Setpoint. The OFF Setpoint is automatically calculated with the new percentage each time you press Select. Calculations use multipliers of 1.25, 1.50, 1.75 and 2.0 for ON Setpoints up to 400fc. Only multipliers of 1.25 and 1.50 are available if ON Setpoint is 475fc or more.

Adjustment Menu

The menu is arranged so that the most common adjustments are readily accessible. For many applications, only the **ON** Setpoint needs to be adjusted. For more advanced applications, the **SETUP** menu offers more options.

There are also two special indicators that may appear above the normal characters in the display: **MEM** and **OVR**.

MEM shows which value is programmed into the LS-102. When stepping through the available choices, MEM appears for the currently programmed choice. The MEM indicator appears for any new value programmed into the LS-102. For instance, if the **Select** button is used to step to a new value and then the **Select** button is pressed and held, after two seconds **MEM** appears. This indicates the new value is now programmed.

OVR appears when automatic control is overridden. There are two ways to override the LS-102. The first is to use the **Select** button when viewing the Control (CTRL) menu. The second is to use the wall switch override, if installed. The first press of either of these overrides turns on the **OVR** indicator to show that automatic control is disabled.

Footcandles (FC)

This is normally the first screen visible when any button is pressed. It displays the current light sensor reading, which updates once a second. Any object that changes the amount of light that reflects into the light sensor will change the readings. Whenever possible, lean away or back down from the LS-102 to see if the light level readings increase. Remove objects from the sensor's field of view if they are not normally in the area.

Control (CTRL)

This screen displays the logical state of the output to the power pack, either **ON** or **OFF**. It also allows temporary override of the output. Press **Select** to toggle the output to its opposite state. If the output was **ON**, one press turns it **OFF** and the **OVR** indicator appears. The status indicator LED also starts to flash slowly. Press **Select** again to turn the output **ON** again while **OVR** indicator remains lit. The output remains overridden **ON** or **OFF** until this screen is exited by pressing the Menu button. Upon exiting, the LS-102 automatically resumes automatic control, the **OVR** indicator turns **OFF** and the LED stops its slow flash. If the display is left on this screen while the output is overridden, the override will timeout in 10 minutes and the LS-102 will return to automatic control.

Observing the Footcandles (FC) display while in override:

If you want to observe the FC reading at the sensor while the lights are either **ON** or **OFF**, you can latch the override state, then maneuver the display back to the FC display to see how the lights **ON** or lights **OFF** states affect the light level coming into the sensor. To latch the output in an override state:

1. Access the CTRL menu item.
2. Press SELECT to override the output, then press and hold SELECT until the MEM indicator appears in the display.
3. To cancel the override, access the CTRL menu again then press the SELECT button or it will automatically timeout in 10 minutes.

ON Setpoint (ON)

When the light level drops below this setpoint for 20 seconds, the lights turn **ON**. Set this value for the lowest level that is acceptable during times when the space is occupied. The **ON** setpoint range is from 1 to 850 footcandles. The default value is 7.5 footcandles. Changing either the **ON** or **OFF** setpoint initiates Test mode for one minute. During this one minute period, the time delays are temporarily made very short. Test mode is indicated by the rapidly flashing status indicator.

OFF Setpoint (OFF)

When the light level exceeds the **OFF** setpoint for the length of the Time Delay, the lights turn **OFF**. Note that the **OFF** setpoint updates when the **ON** setpoint has been changed. The **OFF** Setpoint always maintains a deadband of 25%, 50%, 75% or 100% above the **ON** Setpoint. Any change in the **ON** setpoint causes the **OFF** setpoint to recalculate using the same percentage of deadband as selected for the previous value.

Time Delay (TIME)

This adjustment determines how long the light level must remain above the **OFF** setpoint before the lights turn **OFF**. The available choices are 3 minutes, 10 minutes, 20 minutes and 30 minutes. The default value is 3 minutes.

Setup Submenu (SETUP)

The Setup submenu screen provides access to another set of options. Generally, these options are used in more advanced applications. Press the Select button to access the submenu. Press the Menu button to bypass the Setup submenu and return to the initial footcandle screen.

Auto Cal (auto cal)

Auto Cal invokes an automatic calibration procedure, to select an appropriate value for the **ON** setpoint. As part of this process, the controlled load is first turned **ON**, for a period of two minutes, to warm up the lamps, and then it is switched **OFF** (and back **ON**, as needed) eight times, ending in an **OFF** state. To indicate to the user that AUTO CAL is active, the LED status indicator flashes once every four seconds. At the completion of the calibration, a new value for the **ON** setpoint will have been selected; these results will be shown in the **ON** setpoint display after automatic calibration is completed.

Controlled Electric Load (cel)

Establishes what percentage of the total electric load in the space is actually controlled by the LS-102. This parameter is only used when Automatic Calibration feature is enabled. Every time this parameter is changed, the AUTO CAL procedure must be re-run to take the new value into account. The available choices are 0.33, 0.50, 0.66 and 1.00. 0.33 is recommended when one third of the load is controlled in response to daylight. 0.50 is recommended when half of the load is controlled in response to daylight. 0.66 is recommended when two thirds of the load is controlled in response to daylight. 1.00 is recommended when the entire load is controlled in response to daylight.

Cal Once/Cont (Cal once) (Cal cont)

Cal Once/Cont determines if the Automatic Calibration process occurs once, or if the product should continue to calibrate, based on the average electric light contribution, on an ongoing basis. By default, the **ON** setpoint is only adjusted immediately after the AUTO CAL step.

Test Mode (TEST)

Test Mode temporarily bypasses the normal time delays to facilitate easy testing of the LS-102 light level settings. After 30 minutes, Test Mode ends and the normal time delays are restored. Pressing the Select button in this menu initiates or cancels Test Mode. When Test Mode is active, the LED status indicator flashes rapidly.

Occupancy Hold ON (OCC)

This adjustment option determines whether the occupancy sensor input is used to delay turning **OFF** or if the input signal is ignored. The factory default is Disabled (OCC 15). If the Occupancy function is to be used, then it must be enabled (OCC ENA) from this screen.

Output (OUT)

This adjustment option allows the state of the output to be reversed. The choices are either normal (NORM) or inverted (INV). When the LS-102 is set to Normal, the output signal is 0 VDC when the lights should be **OFF** and 24 VDC when the lights should be **ON**. When the LS-102 is set to Invert, the output signal is 24 VDC when the lights should be **OFF** and 0 VDC when the lights should be **ON**.

Service (Service)

This menu is for use as directed only by Wattstopper technical support. **RESET TO FACTORY DEFAULTS**

This is not a menu item, but can be initiated at any point by pressing and holding both buttons for 5 seconds. When the LS-102 has been reset, the screen will display: LS 102 #.# (current revision number).

LED STATUS INDICATOR

Off	The lights are commanded ON by the LS-102.
On solid green	The lights are commanded OFF by the LS-102.
Green flashes once per second	The LS-102 is in Test Mode.
Green flashes on once every four seconds	Automatic control of the lighting is being overridden either by the wall switch or from the LS-102's Control menu.
Green flashes off once every four seconds	The LS-102 is in Auto Cal mode. It automatically exits when the calibration is completed.

TROUBLESHOOTING

Display does not display any information.

Press either button to wake up the display. Verify that the LS-102 is being powered with 24 VDC.

Lights do not switch when desired.

Use the CTRL menu to manually test **ON** and **OFF** control of the lighting. If the lights switch with manual control, then check the **ON** and **OFF** setpoints. Use test mode to verify setpoints. Use the footcandle display screen to compare the current values with the setpoints.

LED is OFF.

If the controlled lights are **ON**, then the LED is likely operating correctly.

LED is blinking.

If the blink is slow (one blink every four seconds) then the LS-102's output has been forced **ON** or **OFF** by an override from the optional wall switch, or from the Control menu. If the blink is fast (one blink every second), then the LS-102 is in test mode.

WARRANTY INFORMATION

Wattstopper warrants its products to be free of defects in materials and workmanship for a period of five (5) years. There are no obligations or liabilities on the part of Wattstopper for consequential damages arising out of, or in connection with, the use or performance of this product or other indirect damages with respect to loss of property, revenue or profit, or cost of removal, installation or reinstallation.

INFORMATIONS RELATIVES À LA GARANTIE

Wattstopper garantit que ses produits sont exempts de défauts de matériaux et de fabrication pour une période de cinq (5) ans. Wattstopper ne peut être tenu responsable de tout dommage consécutif causé par ou lié à l'utilisation ou à la performance de ce produit ou tout autre dommage indirect lié à la perte de propriété, de revenus, ou de profits, ou aux coûts d'enlèvement, d'installation ou de réinstallation.

INFORMACIÓN DE LA GARANTÍA

Wattstopper garantiza que sus productos están libres de defectos en materiales y mano de obra por un período de cinco (5) años. No existen obligaciones ni responsabilidades por parte de Wattstopper por daños consecuentes que se deriven o estén relacionados con el uso o el rendimiento de este producto u otros daños indirectos con respecto a la pérdida de propiedad, renta o ganancias, o al costo de extracción, instalación o reinstalación.